





**GOVERNMENT OF INDIA  
CENTRAL PUBLIC WORKS DEPARTMENT**

**GENERAL SPECIFICATIONS FOR  
ELECTRICAL WORKS**

**PART-I  
INTERNAL**

**2023**



**PUBLISHED UNDER THE AUTHORITY  
OF  
DIRECTOR GENERAL, CPWD, NEW DELHI**

## **COPYRIGHT**

© All right reserved. No Part of this publication, either in English or Hindi, may be reproduced in any form or by any means, electronic or mechanical including photocopy, recording or any information storage and retrieval system, without permission, in writing, from the Director General, CPWD, New Delhi.

## **DISCLAIMER**

- 1. Whereas every care has been taken to ensure that all relevant and essential provisions required for execution of Construction and Maintenance Works are incorporated in this Specification in a simplified and transparent manner, all executing entities referring to are requested to bring it to the notice of the Directorate, if any conflicting provisions/ discrepancies are noticed in the Specification.*
- 2. This specification is prepared for the use of CPWD. However, this may be used by other government departments, PSUs, private bodies & other institutions or individuals at their own discretion only. CPWD shall not be responsible for any ambiguity, discrepancy, dispute or financial loss, arising directly or indirectly by using or following items in specification by such Government/ Private bodies or individuals.*

## **A GOVERNMENT OF INDIA PUBLICATION**

**Published under the authority of  
Director General  
Central Public Works Department  
Nirman Bhawan  
New Delhi-110011**



**Rajesh Kumar Kaushal**  
Director General



सत्यमेव जयते  
भारत सरकार  
Government of India



केन्द्रीय लोक निर्माण विभाग  
निर्माण भवन, नई दिल्ली-110011  
Central Public Works Department  
Nirman Bhawan, New Delhi-110011  
Tel : 23062556/1317, Fax : 23061884  
E-mail : cpwd\_dgw@nic.in

## FOREWORD

There has been tremendous growth in infrastructure in country with greater focus on sustainable development, energy efficiency, green building norms, improved availability, quality power supply and technological development. This revised edition of "CPWD General Specifications for Electrical Works Part-1 Internal 2023" covers the aspects mentioned above. Various referred codes on wiring practice, earthing, lightning protection etc. have been revised and updated in recent past and the revised specifications incorporate such changes as are applicable now.

This revision reflects the green initiatives in the field of internal electrical installations including lighting aspects covered in ECBC/ CPWD Green Rating compliant buildings/ projects being constructed by CPWD throughout the country. The previous editions were brought out in the year 1972, 1994, 2005 & 2013.

These revised specifications incorporate the relevant provisions of NBC 2016, ECBC 2017, NEC 2023, Central Electricity Authority (Measures related to Safety and Electric Supply) Regulations 2010 (amended in 2015, 2018, 2019) etc covering different aspects related to lighting design & control, safety measures, Earthing and Protection of building against lightning and others. The IS codes mentioned in the specifications were also revised wherever these have undergone change.

I acknowledge the hard work and sincere efforts put in towards this publication by Sh. Dharmesh Chandra Goel, ADG(Tech), Sh. Vikas Rana Chief Engineer, CSQ (E), Sh. Vimal Kumar, CE(E), Sh. Ramayan Prasad Gupta, SE(E)TAS, Sh. Ashok Kumar Meena, EE (E)TAS, Sh. Sandeep Kumar Das, AE(E)TAS and other staff of CSQ(E) whose names are not mentioned for the sake of brevity.

Suggestions for any modifications, errors and omissions may be sent to SE (E) TAS, office of Chief Engineer (E) CSQ, CPWD, Nirman Bhawan, New Delhi.

In case of any discrepancy between English and Hindi versions, the English version shall be held valid.

Place: New Delhi  
Dated: 03.07.2023

  
(Rajesh Kumar Kaushal)  
Director General, CPWD





Dharmesh Chandra Goel  
Addl. Director General (Tech)



भारत सरकार  
Government of India



केन्द्रीय लोक निर्माण विभाग  
निर्माण भवन, नई दिल्ली 110011-  
Central Public Works Department  
Nirman Bhawan, New Delhi-110011  
Tel: 23063389, Fax : 23061833  
Email: adgtd@nic.in

## PREFACE

CPWD envisages a lead role for itself in the execution, maintenance and standardization of the built environment in India, while continuing to play the role of a government department in facilitating the implementation of policies for sustainable development and transparency in governance along with assimilation of knowledge and experience. CPWD strives to educate its clients to aspire for green buildings and develops norms for the same. Its vision is to create and maintain a sustainable and inclusive built environment within the available resources while ensuring world class quality.

The Central Public Works Department (CPWD) is a 168 years old institution and is the principal agency of the Government of India responsible for creating assets and providing comprehensive services including planning, designing, construction and maintenance of office and residential buildings as well as other infrastructures of various ministries, departments of Government of India, autonomous bodies and public sector enterprises. Its activities are spread throughout the country.

The following is the sequence of various editions of CPWD General Specifications for Electrical Works (Internal).

- 1949
- 1960-1972
- 1994
- 2005
- 2013
- 2023 (Present edition)

This edition aims to incorporate latest technological trends and green building norms, energy efficiency in central government buildings being constructed and maintained by CPWD.

The highlight of the present edition are:-



- Green Building initiatives in the field of internal electrical installations for CPWD Green Rating/ ECBC/ GRIHA compliant buildings under construction by CPWD.
- Incorporates the relevant provisions of NBC 2016, ECBC 2017, NEC 2023, Central Electricity Authority (Measures related to Safety and Electric Supply) Regulations 2010 (amended in 2015, 2018, 2019) etc. covering different aspects related to lighting design, lighting control, safety measures.
- Revised chapters for Earthing and Protection of building against lightning including relevant related appendices, tables, charts and diagrams
- Recommended Illuminance levels.
- Life expectancy of various E&M equipment as per latest maintenance manual-2019.
- Important Indian standards are also updated.

I am grateful to Shri Rajesh Kumar Kaushal, Director General, CPWD, Shri Shailendra Sharma, Director General (Former), CPWD for reposing trust in our team to undertake this work. I also express my deep appreciation for Sh. Vikas Rana, Chief Engineer, CSQ (E). Sh. Vimal Kumar, Chief Engineer (E) and the team for drafting these specifications taking into account the updated standards, codes and energy efficiency norms of related items.

I complement Sh. Ramayan Prasad Gupta, SE (E) TAS, CSQ, Sh. Ashok Kumar Meena, EE(E) TAS, Sh. Sandeep Kumar Das, AE(E) TAS, who made their sincere efforts to update the specifications and making the publication available in very short time.

Errors or omissions, and suggestions for improvement, if any, may kindly be brought to the notice of the Superintending Engineer (E) TAS, in the Office of Chief Engineer (E) CSQ, CPWD, New Delhi-110011(Tel No. 01123061418, email: [delseetas.cpwd@nic.in](mailto:delseetas.cpwd@nic.in), [delecetas.cpwd@gov.in](mailto:delecetas.cpwd@gov.in)).

Place: New Delhi  
Dated: 04.07.2023

  
(Dharmesh Chandra Goel)  
ADG (Tech), CPWD



<b>INDEX</b>			
<b>CHAPTER NO</b>	<b>DESCRIPTION</b>	<b>PAGE NO.</b>	
		<b>FROM</b>	<b>TO</b>
<b>CHAPTER 1</b>	<b>GENERAL COMMERCIAL/ TECHNICAL</b>	1	7
<b>CHAPTER 2</b>	<b>PLANNING OF ELECTRICAL INSTALLATION</b>	8	26
<b>CHAPTER 3</b>	<b>ELECTRIC POWER DISTRIBUTION AND WIRING</b>	27	42
<b>CHAPTER 4</b>	<b>METALLIC CONDUIT WIRING SYSTEM</b>	43	47
<b>CHAPTER 5</b>	<b>NON-METALLIC CONDUIT WIRING SYSTEM</b>	48	51
<b>CHAPTER 6</b>	<b>TRUNKING CABLE MANAGEMENT SYSTEM</b>	52	54
<b>CHAPTER 7</b>	<b>POWER SWITCHGEAR AND CONTROLGEAR ASSEMBLIES (PSC-ASSEMBLIES) (LT PANELS), D.B., RISING MAINS, BUS TRUNKING AND OVERHEAD BUS BAR SYSTEM</b>	55	73
<b>CHAPTER 8</b>	<b>EARTHING</b>	74	76
<b>CHAPTER 9</b>	<b>PROTECTION OF BUILDING AGAINST LIGHTNING</b>	77	82
<b>CHAPTER 10</b>	<b>SAFETY PROCEDURE</b>	83	85
<b>CHAPTER 11</b>	<b>FIRE HAZARDS</b>	86	87
<b>CHAPTER 12</b>	<b>ENERGY CONSERVATION</b>	88	91
<b>CHAPTER 13</b>	<b>MAINTENANCE</b>	92	93
<b>CHAPTER 14</b>	<b>PREVENTIVE MAINTENANCE</b>	94	94
<b>CHAPTER 15</b>	<b>PAINTING</b>	95	95
<b>CHAPTER 16</b>	<b>VERIFICATION OF INSTALLATION</b>	96	123
<b>CHAPTER 17</b>	<b>APPENDIX A TO APPENDIX L</b>	124	252
<b>CHAPTER 18</b>	<b>TABLE 1 TO TABLE 11-D</b>	253	294
<b>CHAPTER 19</b>	<b>LIST OF FIGURES</b>	295	304
<b>CHAPTER 20</b>	<b>SPACE FOR ELECTRICAL AND MECHANICAL SERVICES IN BUILDINGS</b>	305	313



<b>LIST OF CHAPTER 17 APPENDIX A TO L</b>			
<b>APPENDIX NO</b>	<b>DESCRIPTION</b>	<b>PAGE NO.</b>	
		<b>FROM</b>	<b>TO</b>
<b>APPENDIX A</b>	<b>TERMINOLOGY</b>	124	130
<b>APPENDIX B</b>	<b>CONVENTIONAL SIGNS &amp; SYMBOLS FOR ELECTRICAL INSTALLATION</b>	131	134
<b>APPENDIX C</b>	<b>IMPORTANT CLAUSES OF CENTRAL ELECTRICITY AUTHORITY (MEASURES RELATING TO SAFETY AND ELECTRIC SUPPLY) REGULATIONS 2010, AND RELATED CLAUSES AMENDED UP TO DATE</b>	135	136
<b>APPENDIX D</b>	<b>IMPORTANT INDIAN STANDARDS</b>	137	148
<b>APPENDIX E</b>	<b>FORM OF COMPLETION CERTIFICATE</b>	149	150
<b>APPENDIX F</b>	<b>EARTHING</b>	151	195
<b>APPENDIX G</b>	<b>GUIDELINES FOR SELECTION AND APPLICATION OF RCCBS (RCDS)</b>	196	200
<b>APPENDIX H</b>	<b>PRINCIPLES OF PROTECTION OF BUILDING AGAINST LIGHTNING</b>	201	226
<b>APPENDIX I</b>	<b>SPECIFICATION AND TESTING OF POWER SWITCHGEAR AND CONTROLGEAR ASSEMBLIES AND BUS BAR/RISING MAINS</b>	227	239
<b>APPENDIX J</b>	<b>SAMPLE CALCULATION FOR REQUIREMENT OF LOGHTNING PROTECTION SYSTEM AND MEASURES</b>	240	247
<b>APPENDIX K</b>	<b>METHOD OF TEST SAMPLING FOR ELECTRICAL ITEMS</b>	248	250
<b>APPENDIX L</b>	<b>ADVISORY FOR PROPER SELECTION OF DESIGN IN RESPECT OF POWER DISTRIBUTIONS IN RESIDENTIAL/ NON-RESIDENTIAL BUILDINGS TO OPTIMIZE NUMBER OF CONDUITS IN THE SLAB</b>	250	252



**CHAPTER 18  
LIST OF TABLES  
TABLE 1 TO 11 H**

<b>TABLE NO</b>	<b>DESCRIPTION</b>	<b>PAGE NO.</b>	
		<b>FROM</b>	<b>TO</b>
<b>TABLE 1</b>	<b>TRIPPING CHARACTERISTICS OF MCBS</b>	253	253
<b>TABLE 2</b>	<b>DUTY CATEGORY OF SWITCHES</b>	254	254
<b>TABLE 3</b>	<b>CLASS OF INSULATION (FOR ELECTRIC MOTORS)</b>	255	255
<b>TABLE 4</b>	<b>FIRE PROTECTION</b>	256	256
<b>TABLE 5</b>	<b>DEGREES OF PROTECTION</b>	257	258
<b>TABLE 6</b>	<b>SELECTION OF LAMPS</b>	259	259
<b>TABLE 7</b>	<b>CAPACITOR SELECTION CHART</b>	260	260
<b>TABLE 8</b>	<b>RECOMMENDED VALUES OF ILLUMINATION AS PER NBC VOL-II, PART 8, SECTION-I</b>	261	281
<b>TABLE 9</b>	<b>EXPECTED USEFUL LIFE OF VARIOUS ELECTRICAL EQUIPMENT/ INSTALLATIONS ETC.</b>	282	285
<b>TABLE 10</b>	<b>LIST OF T&amp;P TO BE HELD BY EACH JUNIOR ENGINEER AS A MAINTENANCE UNIT</b>	286	286
<b>TABLE 11 A</b>	<b>VALUES OF PERFORMANCE CHARACTERISTICS OF 2 POLE LINE OPERATED A.C. MOTORS</b>	287	288
<b>TABLE 11-B</b>	<b>VALUES OF PERFORMANCE CHARACTERISTICS OF 4 POLE LINE OPERATED A.C. MOTORS</b>	289	290
<b>TABLE 11-C</b>	<b>VALUES OF PERFORMANCE CHARACTERISTICS OF 6 POLE LINE OPERATED A.C. MOTORS</b>	291	292
<b>TABLE 11-D</b>	<b>VALUES OF PERFORMANCE CHARACTERISTICS OF 8 POLE LINE OPERATED A.C. MOTORS</b>	293	294



<b>CHAPTER-19 LIST OF FIGURES</b>				
<b>FIG NO</b>	<b>DESCRIPTION</b>	<b>CLAUSE NO.</b>	<b>PAGE NO.</b>	
			<b>FROM</b>	<b>TO</b>
<b>FIG 1</b>	<b>GA DRG FOR FEEDER PILLAR</b>		295	295
<b>FIG 2</b>	<b>TYPICAL SCHEMATIC DIAGRAM FOR POWER DISTRIBUTION FROM SUB-STATION</b>	CLAUSE 3.1.6	296	296
<b>FIG 3</b>	<b>TYPICAL CONNECTION DIAGRAM FROM SDB TO ROOM SWITCH BOARD</b>	CLAUSE 3.5.6	297	297
<b>FIG 4</b>	<b>TYPICAL DESIGN OF M.S. FAN CLAMPS</b>	CLAUSE 3.16 (L)	298	298
<b>FIG 5</b>	<b>CIRCULAR BOX TYPE FAN CLAMP</b>	CLAUSE 3.16 (M)	299	299
<b>FIG 6</b>	<b>TYPICAL CUBICAL PANEL FOR METER BOARD</b>	CLAUSE 3.20.5	300	300
<b>FIG 7</b>	<b>LAYOUT OF ELECTRICAL PANEL</b>	CLAUSE 7.2.1(G)	301	301
<b>FIG 8</b>	<b>PRE-WIRED MCB DISTRIBUTION BOARD (SINGLE PHASE)</b>	CLAUSE 3.18.2	302	302
<b>FIG 9</b>	<b>SCHEMATIC DIAGRAM FOR POWER DISTRIBUTION SYSTEM</b>	CLAUSE 7.3.6	303	303
<b>FIG 10</b>	<b>EARTH TESTING</b>	CLAUSE 16.5.1	304	304

# CHAPTER 1

## GENERAL COMMERCIAL/ TECHNICAL

### 1.1 Scope

1.1.1 In the present times electricity is an absolute necessity for all and the utilization is enhancing with the development of the country. Be it Homes, Offices, Industry, Schools, Hospitals, Transportation, Communication, Road Lighting, Markets all depend on reliable Electric Supply. With further spread of IT and communications which in turn rely on uninterrupted, quality and reliable electric supply, we all are more and more dependent on it. Life comes to a standstill without electricity. Electricity has become an integral and inevitable part of every body's life.

Electricity becomes destructive and dangerous, if not handled with care, and the related safety and preventive measures conforming to laid down safety standards and norms are not complied with. In case of building fires, which often destroy property and lives causing sufferings to the affected people, the first culprit is often supposed to be 'Electric Short Circuit'.

Hence concerns on safety aspects become more crucial and the safety aspects such as protection against electric shock, protection against thermal effect and protection against fire due to arcing, protection against overcurrent and fault current, and protection against voltage disturbance and measures against electromagnetic influences are to be taken into account in the works of Internal EI.

In the above context, the General Specification for Electrical Works (Internal) aims to lay down General guidelines to ensure safe, efficient, reliable, economical use of electricity.

1.1.2 While these Specifications serve as general guidelines, appropriate technical sanctioning authority can depart from such guidelines to meet the particular requirements of any work or for other technical reasons.

1.1.3 This Chapter covers the general commercial and technical requirements applicable to works contract for execution of Internal Electrical Installation works.

1.1.4 These General Specifications are subject to revision from time to time.

### 1.2 Related Documents

Each work has its own particular requirements. Therefore, in addition to the General Specifications, governing BIS, CEA regulations, Standard Contract Conditions etc. there would be necessity of additional conditions/ specifications for a particular work. In case of any discrepancy such additional conditions/ specifications will override these General Specifications.

### 1.3 Terminology

1.3.1 The definition of terms shall be in accordance with IS 732: 2019 (Indian Standard Code of Practice for Electrical Wiring), except for the definitions of point, circuit, and sub main wiring, which are defined in this specification. Some of the commonly used terms are indicated in Chapter 17-Appendix A.

1.3.2 The conventional signs and symbols for technical work shall be as shown in Chapter 17-Appendix B.

### 1.4 Submission of Tenders

The tender shall be submitted complete with the following: -

1.4.1 Complete tender documents as purchased/downloaded from CPWD/website duly filled in and submitted. The price part of the tender shall be indicated only on the tender schedule of work as per NIT.

1.4.2 Earnest Money deposit in one of the specified forms as per laid down rules issued from time to time.

1.4.3 Any other supplementary details required for the evaluation of the tenders such as drawings, technical literature/ catalogues, data etc.

Where one/ two-part tendering system is proposed to be adopted in any particular work (depending upon composite/ EPC or individual Internal EI work), the procedure for submission and opening of tenders shall be indicated in tender documents for that work.

## **1.5 Rates**

- 1.5.1 The work shall be treated as on works contract basis and the rates tendered shall be for complete items of work (except the materials, if any, stipulated for supply by the department) inclusive of all taxes, GST (including works contract tax, if any), duties, and levies etc. and all charges for items contingent to the work, such as, packing, forwarding, insurance, freight and delivery at site for the materials to be supplied by the contractor, watch and ward of all materials (including those, if any, supplied by the department) for the work at site etc.
- 1.5.2 Prices quoted shall be firm. Price adjustments shall however be governed by Clause 10C/ 10CC of the Conditions of Contract given in form CPWD 7 or 8 of the tender documents, for works executed under these forms. All relevant documents shall be produced by the contractor to the Engineer-in-charge, whenever called upon by him to do so, for working out such adjustments in rates.

## **1.6 Taxes and Duties**

- 1.6.1 Being an indivisible works contract, GST or any other taxes or duties etc. are not payable separately.
- 1.6.2 The GST/works contract tax shall be deducted from the bills of the contractor as applicable in the State in which the work is carried out, at the time of payments.

## **1.7 Mobilization Advance**

No mobilization advance shall be paid for the work, unless otherwise stipulated in tender papers for any individual work.

## **1.8 Completeness of Tender**

All sundry fittings, assemblies, accessories, hardware items, foundation bolts, termination lugs for electrical connections as required, and all other sundry items which are useful and necessary for proper assembly and efficient working of the various components of the work shall be deemed to have been included in the tender, irrespective of the fact whether such items are specifically mentioned in the tender documents or not.

## **1.9 Works to be Arranged by the Department**

Unless and otherwise specified in the tender documents, the following works shall be arranged by the Department:

- 1.9.1 Storage space for all equipment, components and materials for the work.
- 1.9.2 Supply of materials to the contractor, if any, stipulated in the tender documents.

**Note:** *In case of EPC contracts, the firm shall be responsible for above as a whole since the complete building/structure to be built shall be within his scope and hence the above items also in firm's scope, which may defined in NIT accordingly.*

## **1.10 Works to be done by the Contractor**

Unless and otherwise mentioned in the tender documents, the following works shall be done by the contractor, and therefore their cost shall be deemed to be included in their tendered cost: -

- 1.10.1 Foundations for equipment and components where required, including foundation bolts.
- 1.10.2 Cutting and making good all damages caused during installation and restoring the same to their original finish.
- 1.10.3 Sealing of all floor openings provided by him for pipes and cables, from fire safety point of view, after laying of the same.
- 1.10.4 Painting at site of all exposed metal surfaces of the installation other than pre-painted items like fittings, fans, switchgear/ distribution gear items, cubicle switchboard etc. Damages to finished

surfaces of these items while handling and erection, shall however be rectified to the satisfaction of the Engineer-in-charge.

1.10.5 Testing and commissioning of complete installation.

1.10.6 The openings/sleeves for the cables, Conduits, Pipes, ducts, rising mains etc. shall be marked in the drawing and provided during construction. No core cutting / openings in walls shall be allowed one the slab is cast or wall is constructed.

### **1.11 Storage and Custody of Materials**

Unless otherwise specified, Suitable space for storage shall be provided by the Department free of cost to the contractor but the required arrangement/set up for storage of materials in the spared space including locking arrangement shall be provided by the agency. Also, the watch and ward of the stores and their safe custody shall be the responsibility of the contractor till the final taking over of the installation by the Department.

**Note: Item no. 1.11 shall not be applicable in case of EPC contract. It shall be the responsibility of EPC contractor only.**

### **1.12 POWER SUPPLY, WATER SUPPLY AND DRAINAGE**

#### **1.12.1 Power Supply**

1.12.2 Unless otherwise specified, 3 phase, 415 Volts, 50 Hz power supply shall be provided by the department free of charge to the contractor at one point. Termination switchgear however, shall be provided by the contractor. Further extension if required shall be done by the contractor and nothing extra shall be paid on this account.

- (i) Unless otherwise specified in the contract, further power distribution to the various equipment shall be done by the contractor.
- (ii) Where the power supply has to be arranged by the Department at more than one point as per the terms of the contract, the termination of all such power feeders in the incomer of respective control panels (provided by the contractor) shall be the responsibility of the contractor.
- (iii) The contractor shall not use the power supply for any other purpose than that for which it is intended for. No major fabrication work shall be done at site. The power supply shall be disconnected in case of such default and the contractor shall then have to arrange the required power supply at his cost.
- (iv) Contractor may have to install their DG Set for construction activity. The department do not guarantee for continuous power supply for the work to be carried out.

**Note:** In case of EPC contracts, the firm shall be responsible for above as a whole since the complete building/structure to be built shall be within his scope and hence the above items are also in firm's scope, which may be defined in NIT accordingly.

#### **1.12.3 WATER SUPPLY**

Unless otherwise specified, water supply shall be made available to the contractor by the Department free of charge at only one point for installation. Further extension if required shall be done by the contractor.

**Note:** *In case of EPC contracts, the firm shall be responsible for above as a whole since the complete building/structure to be built shall be within his scope and hence the above item also as per scope defined in NIT.*

### **1.13 Tools for Handling and Erection**

All tools and tackles required for handling of equipment and materials at site of work as well as for their assembly and erection and also necessary test instruments shall be the responsibility of the contractor.

## **1.14 Payment Terms**

- 1.14.1 Unless otherwise specified in the additional conditions of the contract, the payment shall be made as per the relevant clauses of form PWD 7/8 forming a part of the tender documents.
- 1.14.2 Security deposit shall be deducted in such form and as per provisions contained in CPWD form 7/8 as amended from time to time. The earnest money deposit shall be adjusted against this security deposit. The security deposit shall be released on the expiry of guarantee/ maintenance period stipulated in the contract.  
Original copies of supplier's GST invoice showing contract number, goods description, quantity, packing list, unit price and total amount, dispatch detail, test done at factory etc. have to be submitted by agency for ascertaining the genuinity of material source and supply.

## **1.15 Co-ordination with Other Agencies**

The contractor shall co-ordinate with all other agencies involved in the building work so that the building work is not hampered due to delay in the work. Recessed conduit and other works, which directly affect the progress of building work, should be given priority.

## **1.16 Care of Buildings**

Care shall be taken by the contractor to avoid damage to the building during execution of his part of the work. He shall be responsible for repairing all damages and restoring the same to their original finish at his cost. He shall also remove at his cost all unwanted and waste materials arising out of his work from the site.

## **1.17 Structural Alterations to Buildings**

- 1.17.1 No structural member in the building shall be damaged/altered, without prior approval from the competent authority through the Engineer-in-charge.
- 1.17.2 Structural provisions like openings, cut-outs, if any, provided by the department for the work, shall be used. Where these require modifications, or where fresh provisions are required to be made, such contingent works shall be carried out by the contractor at his cost.
- 1.17.3 All such openings in floors provided by the Department shall be closed by the contractor after installing the cables/ conduits/ rising mains etc. as the case may be, by any suitable means as approved by the Engineer-in-charge without any extra payment.
- 1.17.4 All chases required in connection with the electrical works shall be provided and filled by the contractor at his own cost to the original architectural finish of the buildings.

## **1.18 Addition to an Installation**

Any addition temporary or permanent to the existing electrical installation shall not be made without a properly worked out scheme/ design by a qualified Electrical Engineer to ensure that such addition does not lead to overloading, safety violation of the existing system.

## **1.19 Work in Occupied Buildings**

- 1.19.1 When work is executed in occupied buildings, there would be minimum of inconvenience to the occupants. The work shall be programmed in consultation with the Engineer-in-charge and the occupying department. If so required, the work may have to be done even before and after office hours.
- 1.19.2 The contractor shall be responsible to abide by the regulations or restrictions set in regard to entry into, and movement within the premises.
- 1.19.3 The contractor shall not tamper with any of the existing installations including their switching operations or connections thereto without specific approval from the Engineer-in-charge.

## **1.20 Drawings**

1.20.1 The work shall be carried out in accordance with the drawings enclosed with the tender documents and also in accordance with modification thereto from time to time as approved by the Engineer-in-charge.

In case of EPC contracts, the firm shall be responsible for design of the works and preparation of the related drawings, execution drawings of work including distribution diagram/s, wiring diagram/s and required schematic diagram/s as applicable for which detailed scope of work should be clearly mentioned in the NIT, as per the applicable EPC mode for the contract.

1.20.2 All wiring diagrams shall be deemed to be 'Drawings' within the meaning of the term as used in Clause 11 of the Conditions of Contract (PWD 7 or PWD 8). They shall indicate the main switch board, the distribution boards (with circuit numbers controlled by them), the runs of various mains and sub-mains and the position of all points with their controls.

1.20.3 All circuits shall be indicated and numbered in the wiring diagram and the points shall be given the same number as the circuit to which they are electrically connected.

### **1.20.4 submission of drawings and compliance sheet**

The contractor shall submit the drawings and compliance sheet to the Engineer-in-charge for approval before start of work.

1.21 **Conformity to The Electricity Act 2003, Central Electricity Authority (Measures relating to Safety and Electric Supply) Regulations 2023**

1.21.1 All Electrical works shall be carried out in accordance with the provisions of Indian Electricity Act, 2003 and Central Electricity Authority (Measures relating to Safety and Electric Supply) Regulations 2023, amended up to date (Date of call of tender unless specified otherwise). List of Rules of particular importance to Electrical Installations under these General Specifications is given in Chapter 17 - Appendix C for reference.

## **1.22 General Requirements of Components**

### **1.22.1 SUBMISSION OF PROGRAMME**

As per the time stipulated in the NIT from the date of receipt of the letter of acceptance, the successful tender shall submit a program indicating submission of drawings, supply of equipment, installation, testing, commissioning and handing over of the installation to the Engineer-in-Charge. This program shall be framed keeping in view the milestones stipulated in the contract, wherein building progress shall be given priority. In case of EPC contract, in which Internal EI is one of the works, the complete program for the project will include this work also with detailing, to achieve the overall completion as per the target set for the project, as stipulated in the NIT.

### **1.22.2 Quality of Materials**

All materials and equipment supplied by the contractor shall be new. They shall be of such design, size and materials as to satisfactorily function under the rated conditions of operation and to withstand the environmental conditions at site.

None of the material/ items/ equipment etc supplied shall be more than six months old from date of supply at site. Copy of GST Gate Pass/ Invoice/ Shipment / Custom Clearance certificate/ details (in case of imported equipment) shall be submitted to prove the date of manufacture & genuineness of the equipment/ machines supplied.

### **1.22.3 Inspection of Materials and Equipment**

(a) Materials and equipment to be used in the work shall be inspected by the Departmental officers. Such inspection will be of following categories:

- (i) Inspection of materials/ equipment to be witnessed at the manufacturer's premises in accordance with relevant standards of BIS/ Agreement Inspection Procedure.
- (ii) To receive materials at site with Manufacturer's Test Certificate(s).
- (iii) To inspect materials at the Authorized Dealer's Go downs to ensure delivery of genuine materials at site.
- (iv) To receive materials after physical inspection at site.

(b) The Departmental officers will take adequate care to ensure that only tested and genuine materials

- of proper quality are used in work.
- (c) Similarly, for fabricated equipment, the contractor will first submit dimensional detailed drawings for approval before fabrication is taken up in the factory. Suitable stage inspection at factory also will be made to ensure proper use of materials, workmanship and quality control.
  - (d) The tender specifications will stipulate the inspection requirements or their waiver for various materials/ equipment including norms of inspection in specific cases.

#### 1.22.4 Ratings of Components

- (a) All components in a wiring installation shall be of appropriate ratings of voltage, current, and frequency, as required at the respective sections of the electrical installation in which they are used.
- (b) All conductors, switches and accessories shall be of such size as to be capable of carrying the maximum current, which will normally flow through them, without their respective ratings being exceeded and compliant to related to Indian Standards (BIS).

#### 1.22.5 Conformity to Standards

- (a) All components shall conform to relevant Indian Standard Specifications, wherever existing. Materials with ISI certification mark shall be preferred.
- (b) A broad list of relevant Indian Standards is given in Chapter 17 - Appendix D. These Indian Standards, including amendments or revisions thereof up to the date of tender acceptance, shall be applicable in the respective contracts.

#### 1.22.6 Interchangeability

Similar parts of all switches, lamp holders, distribution fuse boards, switch gears, ceiling roses, brackets, pendants, fans and all other fittings of the same type shall be interchangeable in each installation.

### 1.23 Workmanship

1.23.1 Good workmanship is an essential requirement to be complied with. The entire work of manufacture/ fabrication, assembly and installation shall conform to sound engineering practice.

#### 1.23.2 Proper Supervision/Skilled Workmen

The contractor shall be a licensed electrical contractor of appropriate class suitable for execution of the electrical work. He shall engage suitably skilled/ licensed workmen of various categories for execution of work supervised by supervisors / Engineer of appropriate qualification and experience to ensure proper execution of work. They will carry out instructions of Engineer-in-charge and other senior officers of the Department during the progress of work.

#### 1.23.3 Use of Quality Materials

Only quality materials of reputed make as specified in the tender will be used in work.

#### 1.23.4 Fabrication in Reputed Workshop

Switch boards and LT panels shall be fabricated in a factory/ workshop having modern facilities like quality fabrication, seven tank process, powder/epoxy paint plant, proper testing facilities, manned by qualified technical personnel.

The tender shall specify some quality makes of fabricators with modern facilities of design, fabrication and testing capable of delivering high quality LT panels and switch boards after testing as per relevant specifications and having proper certification for the related type tests as applicable.

### 1.24 Testing

All tests prescribed in these General Specifications, to be done before, during and after installation, shall be carried out, and the test results shall be submitted to the Engineer-in-charge in prescribed Performa, forming part of the Completion Certificate.

### 1.25 Commissioning on Completion

After the work is completed, it shall be ensured that the installation is tested and commissioned.

## **1.26 Completion Plan and Completion Certificate**

- 1.26.1 For all works completion certificate after completion of work as given in Chapter 17 -Appendix E shall be submitted to the Engineer-in-charge. The proformas as enclosed shall also be referred to for the check list, related necessary action and the testing as applicable.
- 1.26.2 Completion plan drawn to a suitable scale indicating the following, along with three print copies of the same shall also be submitted along with related soft copy in pen-drive and/ or CD.
- (a) General layout of the building.
  - (b) Locations of main switchboard and distribution boards, indicating the circuit numbers controlled by them.
  - (c) Position of all points and their controls.
  - (d) Types of fittings, viz LED, pendants, brackets, bulk head, fans and exhaust fans etc.
  - (e) Name of work, job number, accepted tender reference, actual date of completion, names of Division/Sub-Division, and name of the firm who executed the work with their signature.

## **1.27 WARRANTY**

Comprehensively all the goods supplied under the contract shall be new, unused and incorporate all recent improvements in design and materials unless prescribed otherwise in the contract. The supplier further warrants that the goods supplied under the contract shall have no defect arising from design, materials (except when the design adopted and/or the material used are as per the Purchaser's/Consignee's specifications) or workmanship or from any act or omission of the supplier, that may develop under normal use of the supplied goods under the conditions prevailing in India. The warranty shall include all spares, labour and preventive maintenance from the date of completion of the satisfactory installation and acceptance till warranty period. The Comprehensive Annual Maintenance Contract, wherever applicable, shall include all spares, labour and preventive maintenance from the date of completion of the satisfactory installation and acceptance till warranty period.

# CHAPTER 2

## PLANNING OF ELECTRICAL INSTALLATION

### 2.1 Planning of Electrical Installation

The design and planning of an electrical installation involve consideration of all prevailing conditions and is usually guided by the requirement of the consumer. A competent Electrical Engineer should take the responsibility of detailed designing and planning to meet the requirement of various functional needs, efficiency, economy, energy conservation, aesthetics, appropriate technology, safety and avoidance of possible shock and fire hazards. Some of the guiding factors are:

- 2.1.1 Adverse conditions like humidity, high/low ambient temperature, pollution, heat, dust, flame etc. that are likely to affect the installation.
- 2.1.2 Possible presence of inflammable or explosive vapour, gas, liquid.
- 2.1.3 The degree of mechanical and electrical protection necessary.
- 2.1.4 The need of uninterrupted electrical supply, which requires adequate standby system, including generating sets and UPS back up.
- 2.1.5 Flexibility for future modification or extension.
- 2.1.6 Energy cost, which requires proper examination of local electrical tariff.
- 2.1.7 Energy conservation measures.
- 2.1.8 Need of building management system for efficiency and energy cost saving.
- 2.1.9 Relative cost of various alternative methods.
- 2.1.10 Safety aspects such as protection against electric shock, protection against thermal effect and protection against fire due to arcing, protection against overcurrent and fault current, and protection against voltage disturbance and measures against electromagnetic influences.
- 2.1.11 Specific measures for avoidance of possible fire hazards.
- 2.1.12 Use of appropriate technology.
- 2.1.13 Quality control based on appropriate design and use of quality materials and equipment.
- 2.1.14 Aesthetics and co-ordination with Architectural and Structural requirement.
- 2.1.15 Taking into account future growth of load.
- 2.1.16 Need to provide related space/ conduits/ channels/ cables/ wire for services like: Communication cables, computer cabling, fire alarm cabling, UPS cabling etc. CCTV/ Security system cables etc.
- 2.1.17 Reducing operation and maintenance cost with appropriate use of automation, sensors, remote control and microprocessor control for controlling various electrical and mechanical activities.
- 2.1.18 Providing an efficient power distribution system to meet the various power requirements of equipment like:
  - (i) Computers.
  - (ii) ACs.
  - (iii) Pumps.
  - (iv) Lifts.
  - (v) Specific equipment.
  - (vi) Ventilation and smoke extraction system.
  - (vii) AC Plant. etc.

**Note:** Clause 4 of IS732 may be referred for understanding fundamental requirements.

### 2.2 Energy Conservation Building Code (ECBC)

Energy Conservation Building Code (ECBC) issued by Bureau of Energy Efficiency, Ministry of Power, Govt. of India is for providing minimum requirements for the energy efficient design and construction of buildings.

ECBC code at present is applicable to the building or building complexes that have a connected load of 100 kW or greater or contract demand of 120 kVA or greater and are intended to be used

for commercial purpose.

As per ECBC, it prescribes 3 levels of Energy Efficiency:

- (a) Energy Conservation Building Code Compliant Building (ECBC Building).
- (b) Energy Conservation Building Code Plus Building (ECBC+ Building).
- (c) Super Energy Conservation Building Code Building (Super ECBC Building)

**2.2.1** To comply with the ECBC code, the buildings shall have an Energy Performance Index Ratio (EPI) less than or equal to 1 and also meet the mandatory requirements mentioned in ECBC.

The EPI is annual energy consumption per square meter of the building and defined as below;

$$\text{EPI} = \frac{\text{Annual energy consumption in kWh}}{\text{Total building area}} \\ \text{(Excluding unconditioned basement)}$$

As per IS 2:1960 rule EPI value shall be rounded of two decimals.

**Note:** For detailed inputs on above, ECBC may be referred to.

### **2.3 Coordination**

**2.3.1** Before planning is started, coordination and collaboration is needed amongst the following:

Client/ user/ users of the building/ Civil/ Structural Engineer/ Architect/ Horticulture.

**2.3.2** Based on the specific requirement and projected use of the building, conceptual coordinated detailed planning for the entire building will be finalized. The electrical portion has to fit into such integrated concept of the building.

### **2.4 Location and Requirement of Sub-station**

**2.4.1 Electrical sub-station may be required for following reasons:**

- (a) When electric load is in excess of permitted LT supply limit of 'Electrical Supply Authority', which necessitates setting up of sub-station.
- (b) When it is desired to have a sub-station for technical reasons.

#### **2.4.2 Ideal Location**

- (a) The ideal location for an electric sub-station for a building or group of buildings would be at the load centre and shall be located on the ground floor in a separate building. Such building should have direct access through a motorable road to ensure easy access or removal of equipment. The floor level of the sub-station or switch room (in case of LT) shall be above the highest flood level of the locality.
- (b) In case the sub-station has to be located within the main building itself for unavoidable reasons, then it should be located on ground floor with easy access from outside. Location of sub-station in the basement floors should be avoided as far as possible on account of likely flooding and fire hazard. In case it is unavoidable, then fool proof anti-flooding measures have to be taken, which includes provision of automatic dewatering pumping and construction of waterproof basement. Such portion (for sub-station) should be isolated from the rest of basement and should have easy entry and exit arrangement. Also, suitable mechanical ventilation and fire detection/ protection system to be provided to conform to B.I.S. requirements and requirements of local fire authority. Only dry type transformers and switchgear to be provided, unless they are installed in a separate service building separated from the main building.
- (c) Emergency power supply equipment (such as generating sets) shall not be allowed to be installed above ground floor or below first basement level of building.
- (d) Facility for connection from sub-station to adjoining building to feed emergency load shall be permitted.
- (e) In case there is only one basement in a building, the substation/switch room shall not be provided in the basement. Also, the floor level of the substation shall not be lowest point of the basement.
- (f) In order to prevent storm water entering the transformer and switch rooms through the soak- pits, the floor level of the substation/ switch room shall be at least 300 mm above the highest flood

water level that may be anticipated in the locality. Also, facility shall be provided for automatic removal of water.

- (g) Substations with oil-filled equipment/apparatus [transformers and high voltage panels] shall be either located in open or in a utility building. They shall not be located in any floor other than the ground floor or the first basement of a utility building. They shall not be located below first basement slab of utility building. They shall have direct access from outside the building for operation and maintenance of the equipment.
- (h) Substations/Utility buildings (where the substation or oil-filled transformer is located) shall be separated from the adjoining buildings including the main building by at least 6 m clear distance to allow passage of fire tender between the substation/utility building and adjoining building/main building.

#### **2.4.3 Space for Electric Sub-station**

Reference may be made to CPWD specifications for Sub-station Part- IV and “SPACE FOR ELECTRICAL AND MECHANICAL SERVICES IN BUILDINGS” as enclosed with the specifications.

#### **2.4.4 Co-ordination with Local Supply Authority**

The power requirement should be assessed, in consultation with the owner/ users, and discussion should be held with the Electricity supply authority to decide on location/ space required for electricity supply equipment/ meter and tariff involved.

#### **2.4.5 Provision for Future Growth of Load**

The useful life of the building may be more than 50 years. Experience indicates 5 to 10% growth of electrical load every year. Therefore, building should have adequate space provision for augmentation of electrical supply and associated distribution network.

#### **2.4.6 Space for Electrical Services**

Reference may be made to CPWD specifications for Sub-station Part- IV, DG sets Part- VII, Internal EI and External EI specifications, others specifications and “SPACE FOR ELECTRICAL AND MECHANICAL SERVICES IN BUILDINGS” as enclosed with the specifications.

The building has to provide for space for various electrical equipment and service. These include:

- (a) Electrical substation to house HT switchgear, Metering, transformers, LT panels, generating sets, essential LT Panel, Voltage correction devices, UPS, Battery Room, Electrical switch room, vertical shafts for power, communication, fire alarm, UPS cabling, wet riser, associated doors, cut-outs in floors/slabs, cable routes/ trenches/ ducts, cable entry pipes, etc. space for distribution boards etc.
- (b) All such provisions are essential to provide an efficient, safe and aesthetic electrical system for the building.
- (c) In case of indoor substations, space for providing one additional HT panel and one transformer in future shall be kept.

#### **2.4.7 Location of Switch Room and meter room**

Where, it is not necessary to provide a sub-station, a switch room shall be provided. This shall be preferably near the entrance of the building on the ground floor. This switch room shall receive LT supply for which suitable pipe/ trench provision shall be kept for cable entry. Power distribution shall start with suitable number of rising mains (or rising cables) for vertical distribution. A large building will be divided into suitable number of parts, each part served by a rising main. Suitable provision shall be kept for laying cables/ bus duct from switch room to feed each rising main. The requirement shall be coordinated with the local electricity supply agency to identify location and space requirements for their switchgears and metering arrangements also.

#### **2.4.8 Distribution of Supply and Cabling**

A well-designed distribution system will take into account prevailing conditions, various requirement of power so that the installation meets the intended purpose and is safe, and efficient.

#### **2.4.9 System of Supply**

- (a) All electrical equipment, accessories shall be suitable for voltage and frequency of supply of the respective area/ location and shall be finalized in coordination with the local electricity supply agency.

- (b) Use of low voltage, medium voltage or high voltage system or combination thereof is a matter of expert calculation, judgement, comparative studies, prevailing tariff, for ensuring better quality of electric supply, better operation, control and economy of use of equipment, better safety etc. Use of high voltage supply entails provision of suitable transformer substation, which demands additional cost and space. However, such additional cost may be justified for following reasons:
  - (i) Advantage in tariff.
  - (ii) More effective earth fault protection.
  - (iii) Elimination of interference with supplies to other consumers permitting use of large size motors etc.
  - (iv) Better control of voltage.

#### **2.4.10 Stand-by Systems**

Whenever reliable power supply is intended, it is essential to plan for stand by systems like:-

- (a) Incoming supply from two sources.
- (b) Minimum 2 Nos. Transformers, so that in case of failure of one transformer, there is a standby.
- (c) For Data centre requirements, clean regulated power to be ensure eliminating undesirable electrical noise, surge and Spikes. Related detailed specifications for Data centre should be referred to.

### **2.5 Quality of Electric Supply**

**2.5.1** The parameters which decide the quality of electric supply are:-

- (a) Voltage.
- (b) Frequency.
- (c) Power factor
- (d) Absence of harmful harmonics.
- (e) Protection against Surge/ Lightning.

**2.5.2** Modern buildings use large number of electro-mechanical, electronic devices, which for their proper operation and protection require quality electric supply.

**2.5.3** Hence, based on specific needs, suitable additional equipment like voltage correctors, filters, surge protectors, UPS etc. may be provided as an integral part of the electric power system.

### **2.6 Standby Generator Set**

**2.6.1** In the event of mains power failure, it is necessary to provide standby generating sets to meet the requirement of essential power supply, so that the normal working of offices and other institutions, which provide service to the public/users, don't suffer. The essential power loads are as below:-

**(a) Residential**

Water supply and sewerage/ STP pump sets, Lifts.  
 Fire protection/ Firefighting system. Street lighting, common lighting.  
 Essential community needs.

**(b) Non-residential**

Water supply and sewerage/ STP pump sets, Lifts.  
 Fire protection/ Firefighting system. Lights and fans.  
 Exit lights.  
 Staircase, corridor, lobby lights etc.  
 Other requirements like critical air-conditioning, AHUs, essential power out lets etc.

(c) Therefore, it is necessary to provide for essential power supply system consisting of:

- (i) Standby DG Sets
- (ii) Essential LT Power panels.
- (iii) Essential rising mains.
- (iv) Main boards, DB's, essential wiring etc.

## 2.7 Power Factor Management

**2.7.1** Low power factor results in higher current resulting in higher voltage drop and system losses. In order to have control over these parameters power factor of not less than 0.97 lag to be maintained by the power consumers, at the point of connection.

Percentage reduction of load current and transformer loss due to power factor improvement is given in table below:

Initial Power Factor	Power Factor Improvement	% Reduction in Load Current	% Reduction in Transformer Losses
0.7	0.9	23.7	40
0.7	1.0	30.0	51
0.8	0.9	10.0	21
0.8	1.0	20.0	36
0.9	1.0	10.0	19

### 2.7.2 Effect of Leading Power Factor

Leading power factor causes higher voltage; resulting in:

- (a) Increase in hysteresis and eddy current losses.
- (b) Transformer may operate in saturated BH curve, resulting in generation of harmonics, which may lead to heating, and failure of capacitor.

### 2.7.3 Automatic Power Factor Correction Capacitor Banks

Properly designed APFC panels shall be provided to maintain power factor automatically at desired level.

- (i) All 3 phase shall maintain their power factor at the point of connection as follows:
  - (a) 0.97 for ECBC Building (as per the BEE)
  - (b) 0.98 for ECBC+ Building (as per the BEE)
  - (c) 0.99 for Super ECBC Building (as per the BEE)

## 2.8 UPS

**2.8.1** To meet the requirement of no break power supply for requirements like computer/ communication/ security/ life safety needs etc. it may be necessary to provide for centralized/de-centralized UPS system.

**2.8.2** In a centralized UPS system, there will be a third distribution system (besides essential and non-essential power distribution system) consisting of battery room, UPS system, UPS LT Panel, UPS rising main, main boards/ DBs wiring etc.

**2.8.3** Such a system requires carefully designed power switchgear and distribution system, so that in case of power failure, the essential/ UPS loads are connected to their respective sources in a safe and reliable manner.

**2.8.4** As per ECBC, in all buildings Energy efficiency requirements at 100% load UPS shall meet or exceed the energy efficiency as given below:

UPS Size	Energy Efficiency Requirements at 100 % Load
kVA <20	90.2%
20<=kVA<=100	91.9%
kVA>100	93.8%

## **2.9 Allied Services**

**2.9.1** The modern building, besides electric wiring, has to provide for following services:

- (i) Telephone wiring.
- (ii) Communication cabling.
- (iii) Computer cabling, networking, dedicated earthing.
- (iv) Audio-visual systems.
- (v) Security systems.
- (vi) Sound re-enforcement.
- (vii) Stage lighting.
- (viii) External lighting.
- (ix) Architectural in-built lighting.
- (x) Solar Energy system.
- (xi) Photo voltaic power system.
- (xii) Other specific lighting services etc.
- (xiii) Building management system.

**Note: For Specialized buildings like Hospitals, DATA centres etc specialized services like Medical Gas Pipeline System (MGPS), Modular Operation Theatre (MOT), Nurse Call System (NCS), Pneumatic Transport Tube System (PTTS), Precision Air conditioning System (PACS), are also to be planned and related services for electrical installations to be provided accordingly.**

**2.9.2** It is for the electrical planning engineer to coordinate provision of these services in consultation with the user, Architect, structural engineer and specialized agencies.

**2.9.3** Also it is necessary to provide for space/ shafts/ routes and in-built provisions for all these services in the building/ complex.

**2.9.4** The basic guidelines are:-

- (a) Each specialized service will be executed without mixing up with other services.
- (b) Wiring of each service will be taken in its own pipe/ channel, except when it is permitted otherwise.
- (c) Consultation will be made with reputed specialized firms to provide for space and other in-built provision for such services.
- (d) Suitable cat-walk shall be provided as an integral part of the building structure, to provide facility for maintenance of systems provided at higher level.

## **2.10 Lighting Design**

### **2.10.1 Interior Lighting**

Proper lighting level is to be maintained. NBC 2016 specifies lux levels required for various applications. Lower lux level reduces efficiency of working.

Aged person requires higher lux level. For normal office working a middle-aged man requires 350 lux. Proper designing is required for achieving satisfactory lux levels in conformity with NBC 2016-Vol-II, Part-8, Section-1, Table 4 (see Table 8 of specification).

### **2.10.2 Lighting Power Density**

Lighting Power Density is the ratio of the total lighting load of a space to the total lit space area. The installed interior lighting power for a building shall not exceed the interior lighting power allowance determined in accordance with either Building Area Method or Space Function Method as specified in Energy Conservation Building Code (ECBC). The installed interior lighting power shall include all power used by the luminaires, including lamps and ballast.

#### **(a) Building Area Method**

Determination of interior lighting power allowance (watts) by the building area method shall be in accordance with the following:

- (i) Determine the allowed lighting power density for each appropriate building area type as per Table-2.1, Table-2.2 & Table-2.3 of this chapter.
- (ii) Calculate the gross lighted carpet area for each building area type.
- (iii) The interior lighting power allowance is the sum of the products of the gross lighted floor area of each building area times the allowed lighting power density for that building area type.

<b>Table-2.1</b>			
<b>Interior Lighting Power for ECBC Buildings – Building Area Method</b>			
<b>Building Type</b>	<b>LPD (W/m<sup>2</sup>)</b>	<b>Building Area Type</b>	<b>LPD (W/m<sup>2</sup>)</b>
Office Building	9.50	Motion picture theatre	9.43
Hospitals	9.70	Museum	10.2
Hotels	9.50	Post office	10.5
Shopping Mall	14.1	Religious building	12.0
University and Schools	11.2	Sports arena	9.70
Library	12.2	Transportation	9.20
Dining: bar lounge/leisure	12.2	Warehouse	7.08
Dining: cafeteria/fast food	11.5	Performing arts theatre	16.3
Dining: family	10.9	Police station	9.90
Dormitory	9.10	Workshop	14.1
Fire station	9.70	Automotive facility	9.00
Gymnasium	10.0	Convention centre	12.5
Manufacturing facility	12.0	Parking garage	3.00

<b>Table-2.2</b>			
<b>Interior Lighting Power for ECBC+ Buildings – Building Area Method</b>			
<b>Building Area Type</b>	<b>LPD (W/m<sup>2</sup>)</b>	<b>Building Area Type</b>	<b>LPD (W/m<sup>2</sup>)</b>
Office Building	7.60	Motion picture theatre	7.50
Hospitals	7.80	Museum	8.20
Hotels	7.60	Post office	8.40
Shopping Mall	11.3	Religious building	9.60
University and Schools	9.00	Sports arena	7.80
Library	9.80	Transportation	7.40
Dining: bar lounge/leisure	9.80	Warehouse	5.70
Dining: cafeteria/fast food	9.20	Performing arts theatre	13.0
Dining: family	8.70	Police station	7.90
Dormitory	7.30	Workshop	11.3
Fire station	7.80	Automotive facility	7.20

Gymnasium	8.00	Convention centre	10.0
Manufacturing facility	9.60	Parking garage	2.40

<b>Building Area Type</b>	<b>LPD (W/m<sup>2</sup>)</b>	<b>Building Area Type</b>	<b>LPD (W/m<sup>2</sup>)</b>
Office Building	5.0	Motion picture theatre	4.7
Hospitals	4.9	Museum	5.1
Hotels	4.8	Post office	5.3
Shopping Mall	7.0	Religious building	6.0
University and Schools	6.0	Sports arena	4.9
Library	6.1	Transportation	4.6
Dining: bar lounge/leisure	6.1	Warehouse	3.5
Dining: cafeteria/fast food	5.8	Performing arts theatre	8.2
Dining: family	5.5	Police station	5.0
Dormitory	4.6	Workshop	7.1
Fire station	4.9	Automotive facility	4.5
Gymnasium	5.0	Convention centre	6.3
Manufacturing facility	6.0	Parking garage	1.5

In cases where both a general building area type and a specific building area type are listed, the specific building area type shall apply.

**Source : Energy Conservation Building Code 2018, Table 6-1, 6-2 and 6-3.**

**(b) Space Function Method**

Determination of interior lighting power allowance (watts) by the space function method shall be in accordance with the following:

- (i) Determine the appropriate building type and the allowed lighting power density from Table-2.4, Table-2.5 & Table-2.6 of this chapter. In cases where both a common space type and building specific space type are listed, building specific space type LPD shall apply.
- (ii) Determine the quantity of Light fittings to meet the lighting quantity and quality parameters as per IS 3646/NBC 2016, Based on the type of room and activity, following lighting parameters are defined in IS 3646 Task, Illuminance and Surrounding and Background area):
  - Vertical Lighting on face or task area
  - Wall and Ceiling Illuminance
  - Colour Rendering Index
  - Glare Rating (UGR /or otherwise)
  - Other parameter applicable for typical function
- (iii) For each space, enclosed by partitions 80% or greater than ceiling height, determine the gross carpet area by measuring to the face of the partition wall. Include the area of balconies or other projections. Retail spaces do not have to comply with the 80% partition height requirements.
- (iv) The interior lighting power allowance is the sum of the lighting power allowances for all spaces. The lighting power allowance for a space is the product of the gross lighted carpet area of the space times the allowed lighting power density for that space.

<b>Table-2.4</b>			
<b>Interior Lighting Power for ECBC Buildings – Space Function Method</b>			
<b>Category</b>	<b>LPD (W/m<sup>2</sup>)</b>	<b>Lamp Category</b>	<b>LPD (W/m<sup>2</sup>)</b>
<b>Common Space Type</b>			
Restroom	7.70	Stairway	5.50
Storage	6.80	Corridor/Transition	7.10
Conference/ Meeting	11.5	Lobby	9.10
Parking Bays (covered/ basement)	2.20	Parking Driveways (covered/ basement)	3.00
Electrical/Mechanical	7.10	Workshop	17.1
<b>Business</b>			
Enclosed	10.0	Open Plan	10.0
Banking Activity Area	12.6	Service/Repair	6.80
<b>Healthcare</b>			
Emergency	22.8	Recovery	8.60
Exam/Treatment	13.7	Storage	5.50
Nurses' Station	9.40	Laundry/Washing	7.50
Operating Room	21.8	Lounge/Recreation	8.00
Patient Room	7.70	Medical Supply	13.7
Pharmacy	10.7	Nursery	5.70
Physical Therapy	9.70	Corridor/Transition	9.10
Radiology/Imaging	9.10		
<b>Category</b>	<b>LPD (W/m<sup>2</sup>)</b>	<b>Lamp Category</b>	<b>LPD (W/m<sup>2</sup>)</b>
<b>Hospitality</b>			
Hotel Dining	9.10	Hotel Lobby	10.9
For Bar Lounge/ Dining	14.1	Motel Dining	9.10
For food preparation	12.1	Motel Guest Rooms	7.70
Hotel Guest Rooms	9.10		
<b>Shopping Complex</b>			
Mall Concourse	12.8	For Family Dining	10.9
Sales Area	18.3	For food preparation	12.1
Motion Picture Theatre	9.60	Bar Lounge/ Dining	14.1
<b>Educational</b>			
Classroom/Lecture	13.7	Card File and Cataloguing	9.10
For Classrooms	13.8	Stacks (Lib)	18.3
Laboratory	15.1	Reading Area (Library)	10.0
<b>Assembly</b>			
Dressing Room	9.10	Seating Area - Performing Arts Theatre	22.6
Exhibit Space - Convention Centre	14.0	Lobby - Performing Arts Theatre	21.5
Seating Area -	4.60	Seating Area -	6.40

Gymnasium		Convention Centre	
Fitness Area - Gymnasium	13.70	Seating Religious Building	16.4
Museum - General Exhibition	16.40	Playing Area - Gymnasium	18.8
Museum - Restoration	18.3		

<b>Table-2.5</b>			
<b>Interior Lighting Power for ECBC+ Buildings – Space Function Method</b>			
<b>Category</b>	<b>LPD (W/m<sup>2</sup>)</b>	<b>Lamp Category</b>	<b>LPD (W/m<sup>2</sup>)</b>
<b>Common Space Type</b>			
Restroom	6.10	Stairway	4.40
Storage	5.40	Corridor/Transition	3.60
Conference/ Meeting	9.20	Lobby	7.30
Parking Bay (covered/ basement)	1.80	Parking Driveways (covered/ basement)	2.50
Electrical/Mechanical	5.70	Workshop	13.7
<b>Business</b>			
Enclosed	8.60	Open Plan	8.60
Banking Activity Area	9.30	Service/Repair	5.50
<b>Healthcare</b>			
Emergency	18.2	Recovery	7.00
Exam/Treatment	10.9	Storage	4.40
Nurses' Station	7.50	Laundry/Washing	6.00
Operating Room	17.5	Lounge/Recreation	6.40
Patient Room	6.10	Medical Supply	10.9
Pharmacy	8.50	Nursery	4.60
Physical Therapy	7.80	Corridor/Transition	7.30
Radiology/Imaging	7.30		
<b>Category</b>	<b>LPD (W/m<sup>2</sup>)</b>	<b>Lamp Category</b>	<b>LPD (W/m<sup>2</sup>)</b>
<b>Hospitality</b>			
Hotel Dining	7.30	Hotel Lobby	8.80
For Bar Lounge/ Dining	11.3	Motel Dining	7.30
For food preparation	12.1	Motel Guest Rooms	6.10
Hotel Guest Rooms	7.30		
<b>Shopping Complex</b>			
Mall Concourse	10.2	For Family Dining	8.80
Sales Area	14.6	For food preparation	12.1
Motion Picture Theatre	10.3	Bar Lounge/ Dining	11.3
<b>Educational</b>			
Classroom/Lecture	10.9	Card File and Cataloguing	7.30
For Classrooms	11.0	Stacks (Library)	14.6
Laboratory	12.1	Reading Area (Library)	9.20
<b>Assembly</b>			
Dressing Room	7.30	Seating Area - Performing Arts Theatre	18.1

Exhibit Space - Convention Centre	11.2	Lobby - Performing Arts Theatre	17.2
Seating Area - Gymnasium	3.60	Seating Area – Convention Centre	5.10
Fitness Area - Gymnasium	7.90	Seating Religious Building	13.1
Museum - General Exhibition	11.3	Playing Area - Gymnasium	12.9
Museum - Restoration	11.0		

<b>Table-2.6</b>			
<b>Interior Lighting Power for Super ECBC Buildings – Space Function Method</b>			
<b>Category</b>	<b>LPD (W/m<sup>2</sup>)</b>	<b>Lamp Category</b>	<b>LPD (W/m<sup>2</sup>)</b>
<b>Common Space Type</b>			
Restrooms	3.80	Stairway	2.70
Storage	3.40	Corridor/Transition	2.30
Conference/ Meeting	5.70	Lobby	4.60
Parking Bays (covered/ basement)	1.10	Driveways (covered/ basement)	1.50
Electrical/Mechanical	3.50	Workshop	8.60
<b>Business</b>			
Enclosed	5.40	Open Plan	5.40
Banking Activity Area	5.80	Service/Repair	3.40
<b>Healthcare</b>			
Emergency	11.4	Recovery	4.40
Exam/Treatment	6.80	Storage	2.70
Nurses' Station	5.00	Laundry/Washing	3.80
Operating Room	10.9	Lounge/Recreation	4.60
Patient Room	3.80	Medical Supply	6.80
Pharmacy	5.30	Nursery	2.90
Physical Therapy	4.90	Corridor/Transition	4.60
Radiology/Imaging	4.60		
<b>Hospitality</b>			
Hotel Dining	4.60	Hotel Lobby	5.50
For Bar Lounge/ Dining	7.00	Motel Dining	4.60
For food preparation	7.50	Motel Guest Rooms	3.80
Hotel Guest Room	4.60		
<b>Shopping Complex</b>			
Mall Concourse	6.40	For Family Dining	5.50
Sales Area	9.20	For food preparation	7.50
Motion Picture Theatre	6.50	Bar Lounge/ Dining	7.00
<b>Educational</b>			
Classroom/Lecture	6.80	Card File and Cataloguing	4.60
For Classrooms	6.90	Stacks (Library)	9.20
Laboratory	7.50	Reading Area (Library)	5.70
<b>Assembly</b>			

Dressing Room	4.60	Seating Area - Performing Arts Theatre	11.3
Exhibit Space – Convention Centre	7.00	Lobby - Performing Arts Theatre	10.8
Seating Area - Gymnasium	3.40	Seating Area – Convention Centre	3.20
Fitness Area - Gymnasium	3.92	Seating Religious Building	8.20
Museum – General Exhibition	5.65	Playing Area - Gymnasium	6.50
Museum - Restoration	5.50		

(Source : Energy Conservation Building Code 2017, Table 6-4, 6-5 and 6-6)

**(c) Calculating Interior Lighting Power – Space Function Method**

A four-story building has retail on the ground floor and offices on the top three floors. Area is 3,600 m<sup>2</sup>. Space types and their respective areas are mentioned below. Steps for calculating interior lighting power allowance using the space function method for a ECBC building is described below. For each of the space type, corresponding Lighting Power Density (LPD) values for Business and Shopping complex building type from Table I are used. Area is multiplied with the LPD values to estimate the lighting power allowance for the whole building. It is 40,055.5 W.

Space Function	LPD (W/m <sup>2</sup> )	Area (m)	Lighting Power Allowance (W)
<b>Office</b>			
Office-enclosed	10.0	720	7200
Office-open plan	10.0	1485	14850
Meeting Rooms	11.5	120	1380
Lobbies	7.1	93	660
Restrooms	7.7	51	393
Corridors	7.1	125	887.5
Electrical/Mechanical	7.1	14	99
Staircase	5.5	84	462
<b>Total</b>			<b>25931.5</b>
<b>Retail</b>			
General Sales Area	18.3	669	12243
Offices-enclosed	10.0	28	280
Restrooms	7.7	9	69
Corridors	7.1	79	561
Active Storage	6.8	93	632
Food Preparation	12.1	28	339
<b>Total</b>			<b>14124</b>
<b>Building Total</b>			<b>40055.5 W</b>

**2.10.3 Installed Interior Lighting Power**

The installed interior lighting power calculated for compliance with 2.10 shall include all power used by the luminaires, including lamps, ballasts, current regulators, and control devices.

Exception to above, if two or more independently operating lighting systems in a space are controlled to prevent simultaneous user operation, the installed interior lighting power shall be based solely on the lighting system with the highest power.

#### 2.10.4 Luminaire Wattage

Light output ratio shall be 0.7 (not applicable for LED Luminaires) or above. Luminaire wattage incorporated into the installed interior lighting power shall be determined in accordance with the following:

- (a) The wattage of incandescent luminaires with medium base sockets and not containing permanently installed ballasts shall be the maximum labelled wattage of the luminaires.
- (b) The wattage of luminaires containing permanently installed ballasts shall be the operating input wattage of the specified lamp/ballast combination. Operating input wattage can be either values from manufacturers' catalogues or values from independent testing laboratory reports.
- (c) The wattage of all other miscellaneous luminaire types not described in (a) or (b) shall be the specified wattage of the luminaires.
- (d) The wattage of lighting track, plug-in busway, and flexible-lighting systems that allow the addition and/ or relocation of luminaires without altering the wiring of the system shall be the larger of the specified wattage of the luminaires included in the system or 135 Watt per meter (45 W/ft.). Systems with integral overload protection, such as fuses or circuit breakers, shall be rated at 100% of the maximum rated load of the limiting device.

#### 2.10.5 Exterior Lighting Power

Connected lighting power of exterior lighting applications shall not exceed the lighting power limits specified in Table 2.7 for ECBC Buildings, Table 2.8 for ECBC+ Buildings and Table 2.9 for Super ECBC Buildings. Trade-offs between applications are not permitted.

**Table 2.7**  
**Exterior Building Lighting Power for ECBC Buildings**

<b>Exterior lighting application</b>	<b>Power limits</b>
Building entrance (with canopy)	10 W/m <sup>2</sup> of canopied area
Building entrance (w/o canopy)	90 W/ linear m of door width
Building exit	60 W/lin m of door width
Building façade	5.0 W/ m <sup>2</sup> of vertical façade area
Emergency signs, ATM kiosks, Security areas façade	1.0 W/ m <sup>2</sup>
Driveways and parking (open/ external)	1.6 W/ m <sup>2</sup>
Pedestrian walkways	2.0 W/ m <sup>2</sup>
Stairways	10.0 W/ m <sup>2</sup>
Landscaping	0.5 W/m <sup>2</sup>
Outdoor sales area	9.0 W/ m <sup>2</sup>

**Table 2.8**  
**Exterior Building Lighting Power for ECBC+ Buildings**

<b>Exterior lighting application</b>	<b>Power limits</b>
Building entrance (with canopy)	8.0 W/ m <sup>2</sup> of canopied area
Building entrance (w/o canopy)	72 W/ linear m of door width
Building exit	48 W/lin m of door width
Building façade	4.0 W/m <sup>2</sup> of vertical façade area
Emergency signs, ATM kiosks, Security areas façade	0.8 W/ m <sup>2</sup>
Driveways and parking (open/ external)	1.3 W/ m <sup>2</sup>
Pedestrian walkways	1.6 W/ m <sup>2</sup>
Stairways	8.0 W/ m <sup>2</sup>
Landscaping	0.4 W/ m <sup>2</sup>
Outdoor sales area	7.2 W/ m <sup>2</sup>

**Table 2.9**  
**Exterior Building Lighting Power for Super ECBC Buildings**

<b>Exterior lighting application</b>	<b>Power limits</b>
Building entrance (with canopy)	5.0 W/ m <sup>2</sup> of canopied area
Building entrance (w/o canopy)	45 W/ linear m of door width
Building exit	30 W/lin m of door width
Building façade	2.5 W/m <sup>2</sup> of vertical façade area
Emergency signs, ATM kiosks, Security areas façade	0.5 W/ m <sup>2</sup>
Driveways and parking (open/ external)	0.8 W/ m <sup>2</sup>
Pedestrian walkways	1.0 W/ m <sup>2</sup>
Stairways	5.0 W/ m <sup>2</sup>
Landscaping	0.25 W/ m <sup>2</sup>
Outdoor sales area	4.5 W/ m <sup>2</sup>

*(Source: Energy Conservation Building Code 2017, Table 6-7, Table 6-8 & Table 6-9)*

### **2.10.6 False Ceiling Coordination**

False ceiling electrical layout will be coordinated with the Architect and the Civil Engineer so that reflected ceiling drawing provides for symmetrical and aesthetic layout of the following:

- (a) Fans, Light fittings
- (b) A/C Diffusers, grills, out lets, ventilation arrangements
- (c) Fire detectors
- (d) Sprinklers
- (e) AV equipment like Speakers etc.

### **2.10.7 Functional Areas like Auditorium, Conference Hall, Computer Rooms, and Library**

Special attention to be paid for functional areas to meet the client's requirements, and functional requirements in coordination with the Architect and to provide for specialized services like Audio visual system, P.A. System, Sound reinforcement, Stage lighting, Conference system, Security needs, etc. It may be noted that provision of such services at a later stage will not only mar the aesthetics of the building, also will compromise with efficiency of such services for want of proper space etc.

### **2.10.8 Areas like Hospitals, Stadia**

Planning of such buildings require high degree of professionalism, for application of latest technology to provide efficient and effective installation.

## **2.11 Outdoor Lighting, High Mast Lighting, Road Lighting, Security Lighting, Garden Lighting, Illuminated Fountains**

Present day modern buildings require highly aesthetic lighting making use of a variety of lighting design, themes and fixtures available. For proper aesthetic effect, high level of professional approach is needed based on computer aided design and calculations.

### **2.11.1 Night Sky Pollution & Light Trespass**

All exterior lighting should be designed to minimize night sky pollution. Only those areas shall be lighted that are required for safety and comfort. Installation of luminaires on site and building shall be such that no light trespassing occurs on the neighboring site and buildings.

#### **(a) For Interior Lighting**

The angle of maximum candela from each interior luminaire as located in the building shall intersect opaque building interior surfaces and not exit out through windows.

#### **(b) For Exterior Lighting**

All projects defined under the following zones shall follow the requirements for that specific zone as given below:

##### **(i) Dark (Park and Rural Settings)**

Design exterior lighting so that all site and building mounted luminaires produce a maximum initial illuminance value no greater than 0.107 horizontal and vertical lux at the site boundary and beyond. Lighting Fixture: 0% of the total initial fixture lumens are emitted at an angle of 90 degree or higher from nadir.

##### **(ii) Low (Residential Areas)**

Design exterior lighting so that all site and building mounted luminaires produce a maximum initial illuminance value no greater than 0.107 horizontal and vertical lux at the site boundary and no greater than 0.107 horizontal lux 10 feet beyond the site boundary. Lighting Fixture: 2% of the total initial fixture lumens are emitted at an angle of 90 degree or higher from nadir.

##### **(iii) Medium (Commercial/ Industrial, High Density Residential)**

Design exterior lighting so that all site and building mounted luminaires produce a maximum initial illuminance value no greater than 2.152 horizontal and vertical lux at the site boundary and no greater than 0.107 horizontal lux 15 feet beyond the site boundary. Lighting Fixture: 5% of the total initial fixture lumens are emitted at an angle of 90 degree or higher from nadir.

##### **(iv) High (Major City Centre, Entertainment Districts)**

Design exterior lighting so that all site and building mounted luminaires produce a maximum initial illuminance value no greater than 6.458 horizontal and vertical lux at the site boundary and no greater than 0.107 horizontal lux 15 feet beyond the site boundary. Lighting Fixture: 10% of the total initial fixture lumens are emitted at an angle of 90 degree or higher from nadir.

## **2.12 LED Lighting**

### **2.12.1 Features of LED Lighting:**

- (a) Energy saving
- (b) Long Life
- (c) Rugged and Durable
- (d) Smaller lighting Fixture
- (e) Environment friendly – no mercury
- (f) Instant starting
- (g) Dimmable for automation
- (h) Available in different colors

### 2.12.2 Challenges of LED Lightings:

- (i) Ensuring Quality.
- (ii) Still in development stage. Efficiency of LED luminaries is continuously being upgraded.
- (iii) Number of electronic items in LED luminaries like driver, PCB, power supply etc. affect LED life.
- (iv) Quality of phosphor coating on LED.
- (v) Diffuser used in LED luminaries, reduces its lumen output.
- (vi) Heat Management.
- (vii) Junction temperature v/s lumen output.

### 2.12.3 Design Parameter for selecting source of lighting while designing lighting of building/ campus:

Following important parameters be kept in view while deciding the suitable light source for indoor lighting: -

- (a) CRI of the source.
- (b) Usable lumen per watt of fitting
- (c) Glaring index of fixture
- (d) Life of the lamp

**2.12.4** LED lighting has become efficient (luminous efficacy) and with good CRI over HPSV lamp as well as metal halide lamp, hence it can be used for outdoor lighting applications which are being done by HPSV and Metal halide lamps.

- (a) In indoor applications for down lighters, task lighting etc. where CFL luminaires are being used, the luminous efficacy of the LED luminaires is comparable and due to higher life can be used for such applications.
- (b) Since light output and life of LED is dependent on the driver current and junction temperature, Indian standards for the LED are available now and should be specified while using the LED fittings.

### 2.13 Electrical and Renewable Energy System

As specified in ECBC, all electric and renewable energy equipment and systems shall comply with the mandatory requirements as given below.

#### 2.13.1 Transformers

##### 2.13.1.1 Maximum Allowable Power Transformer Losses

Power transformers of the proper ratings and design must be selected to satisfy the minimum acceptable efficiency at 50% and full load rating.

- (a) For dry type transformers, refer values listed in Table 2.10 below for maximum permissible loss.

**Table 2.10**  
**Dry Type Transformers**

(Source Energy Conservation Building Code 2017, Table 7-1)

Rating kVA	Max. Losses at 50% loading kW*	Max. Losses at 100% loading kW*	Max. Losses at 50% loading kW*	Max. Losses at 100% loading kW*
Up to 22 kV class		33 kV class		
100	0.94	2.4	1.12	2.4
160	1.29	3.3	1.42	3.3
200	1.5	3.8	1.75	4.0
250	1.7	4.32	1.97	4.6

315	2.0	5.04	2.4	5.4
400	2.38	6.04	2.9	6.8
500	2.8	7.25	3.3	7.8
630	3.34	8.82	3.95	9.2
800	3.88	10.24	4.65	11.4
1000	4.5	12.00	5.3	12.8
1250	5.19	13.87	6.25	14.5
1600	6.32	16.8	7.5	18.00
2000	7.5	20.00	8.88	21.4
2500	9.25	24.75	10.75	26.5
* The total loss values given in above table are applicable for thermal classes E, B and F. An increase of 7% on total loss value for thermal class H is allowed."				
* The values as per Indian Standard/BEE Standard & Labelling notification for dry type transformer corresponding to values in this table will supersede as and when the Indian standards/ BEE Standard & Labelling notification are published.				

**(b) Maximum Allowable Oil Type Power Transformer Losses :**

- (i) For transformers of HV voltage up to 11 kV, the total losses (no-load + load losses at 75°C) at 50 percent of rated load and total losses at 100 percent of rated load shall not exceed the maximum total loss values given in Table 2.11.
- (ii) For transformers having voltage class above 11 kV and up to and including 22 kV, the permissible total loss values shall not exceed by 5 percent of the maximum total loss values mentioned in Table 2.11.
- (iii) For transformers having voltage class above 22 kV and up to and including 33kV, the permissible total loss values shall not exceed by 7½ percent of the maximum total loss values mentioned in Table 2.11.

**Table 2.11**  
**Permissible Losses for Oil Type Transformers**  
**Total losses for oil type transformers shall confirm with Indian Standard**  
**IS 1180 (Amendment No. 4<sup>th</sup> March 2021)**

Sl.no.	Rating (kVA)	Impedance %	Maximum Total Loss (W)									
			Energy Efficiency Level -1		Energy Efficiency Level -2		Energy Efficiency Level -3		Energy Efficiency Level -4		Energy Efficiency Level -5	
			50% Load	100% Load	50% Load	100% Load	50% Load	100% Load	50% Load	100% Load	50% Load	100% Load
1	2	3	4	5	6	7	8	9	10	11	12	13
i)	16	4.50	135	440	120	400	108	364	97	331	87	301
ii)	25	4.50	190	635	175	595	158	541	142	493	128	448

iii)	63	4.50	340	1140	300	1050	20	956	243	870	219	791
iv)	100	4.50	475	1650	435	1500	392	1365	352	1242	317	1130
v)	160	4.50	670	1950	570	1700	513	1547	462	1408	416	1281
vi)	200	4.50	780	2300	670	2100	603	1911	543	1739	488	1582
vii)	250	4.50	980	2930	920	2700	864	2488	811	2293	761	2113
viii)	315	4.50	1025	3100	955	2750	980	2440	829	2164	772	1920
ix)	400	4.50	1225	3450	1150	3330	1080	3214	1013	3102	951	2994
x)	500	4.50	1510	4300	1430	4100	1354	3909	1282	3727	1215	3554
xi)	630	4.50	1860	5300	1745	4850	1637	4438	1536	4061	1441	3717
xii)	800	5.00	2287	6403	2147	5838	2015	5323	1892	4853	1776	4425
xiii)	1000	5.00	2790	7700	2620	7000	2460	6364	2310	5785	2170	5259
xiv)	1250	5.00	3300	9200	3220	8400	3142	7670	3066	7003	2991	6394
xv)	1600	6.25	4200	11800	3970	11300	3753	10821	3547	10363	3353	9924
xvi)	2000	6.25	5050	15000	4790	14100	4543	13254	4309	12459	4088	11711
xvii)	2500	6.25	6150	18500	5900	17500	5660	16554	5430	15659	5209	14813

#### 2.13.1.2 Measurement and Reporting of Transformer Losses

All measurement of losses shall be carried out by using calibrated digital meters of class 0.5 or better accuracy and certified by the manufacturer. All transformers of capacity of 500 kVA and above would be equipped with additional metering class current transformers (CTs) and potential transformers (PTs) additional to requirements of Utilities so that periodic loss monitoring study may be carried out.

#### 2.14 Voltage Drop

Voltage drop for feeders shall not exceed 2% at design load. Voltage drop for branch circuit shall not exceed 3% at design load.

#### 2.15 Use of Solar PV System for Outdoor Lighting

Provision as in ECBC for outdoor lighting with solar PV system should be complied with. However, in places/complexes where load shedding is frequent, provision of solar PV outdoor lighting should be adopted, preferably with hybrid system.

**Note:** The provisions may be suitably modified as per Local body bye laws requirements.

#### 2.16 Renewable Energy Generation System Capacity

A renewable energy system shall be installed in the building equivalent to 1% of total connected load and its rated capacity shall be as per the Local body bye laws requirements/ ECBC, complying to at least minimum require of the same. However, effort shall be made for providing maximum possible solar pv power generation system.

#### 2.17 Renewable Energy Based Water Heating System Capacity

Residential facilities, hotels and hospitals with a centralized system shall have solar water heating for at least one-fifth of the design capacity.

It is recommended that the capacity of the hot water system is such that the annual energy saved by proposed renewable energy system is more than 70% of annual energy required for water heating to meet the hot water requirements of the occupants in the building.

**Exception to above:**

If the hot water requirement is less than 500 liters per day.

System Efficiency

Solar water heater shall meet the performance/ minimum efficiency level mentioned in IS 13129 Part 1 & 2 (1991).

**Note:** The provisions may be suitably modified as per Local body bye laws requirements.

**2.18 Emergency power for fire and life safety systems :**

Emergency power supplying distribution system for critical requirement for functioning of fire and life safety system and equipment shall be planned for efficient and reliable power and control supply to the following systems and equipment where provided:

- (a) Fire pumps.
- (b) Pressurization and smoke venting; including its ancillary systems such as dampers and actuators.
- (c) Fireman.s lifts (including all lifts).
- (d) Exit signage lighting.
- (e) Emergency lighting.
- (f) Fire alarm system.
- (g) Public address (PA) system (relating to emergency voice evacuation and annunciation).
- (h) Magnetic door hold open devices.
- (i) Lighting in fire command centre and security room.

The power supply to the panel/distribution board of these fire and life safety systems shall be through fire proof enclosures or circuit integrity cables or through alternate route in the adjoining fire compartment to ensure supply of power is reliable to these systems and equipment. It shall be ensured that the cabling from the adjoining fire compartment is protected within the compartment of vulnerability. The location of the panel/ distribution board feeding the fire and life safety system shall be in fire safe zone ensuring supply of power to these systems.

Circuits of such emergency system shall be protected at origin by an automatic circuit breaker with its no-volt coil removed. Master switches controlling essential service circuits shall be clearly labelled.

## CHAPTER 3

### ELECTRIC POWER DISTRIBUTION AND WIRING

#### 3.1 Introduction

The electric power will be received and distributed in a building, through following means:-

##### 3.1.1 Cabling and switchgear to receive power.

The building is divided into convenient number of parts, each part served by a rising main system to distribute power vertically/horizontally.

##### 3.1.2 Power flows from rising main through tap-off box to floor main board to final DBs and then to wiring.

##### 3.1.3 Dedicated circuit for different loads such as lighting, HVAC, power plug loads shall be provided, wherever possible.

##### 3.1.4 Rising main, which takes care of general lighting and power outlet load of the building, should have independent cables for lighting as well as power, wherever possible. Other loads like lifts, water pump sets, other motor loads are fed by independent cables of suitable capacity fed from properly designed essential/ non- essential LT power panels with suitably designed switchgear having necessary control and safety features.

##### 3.1.5 Therefore, the distribution/wiring system essentially consists of provision of cables, switchgear, rising main, bus-ducting, earthing, laying of pipes/ conduits etc. (in surface or recess) based on proper detailed designing to decide on various sizes/ capacities of these components and various controls and safeties involved, to provide an efficient, reliable, safe and adequate electrical distribution and wiring system.

##### 3.1.6 A typical schematic diagram of power distribution of a building is enclosed. (See Chapter 19 Fig. 2).

##### 3.1.7 **Fire Prevention – Lifesaving and Restricting Damages to the Property**

Fire Survival (FS) cables shall be used where integrity of electric supply is important especially to save human life and where electric supply is required for evacuation operation during the fire instances. These cables are designed to withstand temperatures from 650<sup>0</sup>C to 950<sup>0</sup>C and for period upto 180 min along with additional protection against mechanical shock and water splash. The fire survival cable shall be used at following location as given below and additional requirement, if any as mentioned in NBC 2016 as amended up to date, CEA Regulation 2010 as amended up to date and NEC 2023 :-

<b>Application of FS cable</b>			
NOTE – For more details, refer Annex A of IS 17505(Part 1) : 2020			
SI No.	System Description	Cable Fire Rating Required (°C)	Time for which System should Withstand (Minutes)
(1)	(2)	(3)	(4)
(i)	Fire pumps	FS (950/FWS)	180
(ii)	Pressurization	FS (950/FWS)	180
(iii)	Smoke venting including its ancillary systems, such as dampers and actuators	950	60
(iv)	Fire-fighting shaft (staircase, lift, lift lobby)	FS (950/FWS)	180
(v)	Fireman’s lifts (including all lifts)	FS (950/FWS)	180
(vi)	Exit signage lighting	950	120
(vii)	Emergency lighting	950	120
(viii)	Fire alarm system		

(a)	Conventional (zone-based system)	650	60
(b)	Intelligent addressable system	650	60
(ix)	Public address (PA) system (related to emergency voice evacuation and annunciation)	650	60
(x)	Magnetic door hold-open devices	650	60
(xi)	Lighting in fire command center and security room	FS (950/FWS)	180

### 3.2 System of Distribution and Wiring

- 3.2.1 The wiring shall be done from a distribution system through main and/or branch distribution boards. The system design and location of boards will be properly worked out.
- 3.2.2 Each main distribution board and branch distribution board shall be controlled by an incoming circuit breaker. Each outgoing circuit shall be controlled by a circuit breaker.
- 3.2.3 For non-residential and residential buildings as far as possible DBs shall be separate for light and power.
- 3.2.4 Only MCCB/MCB type main and branch distribution boards shall be used. HRC/ Rewireable type fuses shall not be used.
- 3.2.5 Three phase DBs shall not be used for final circuit distribution as far as possible.
- 3.2.6 'Power' wiring shall be kept separate and distinct from light wiring, from the level of circuits, i.e., beyond the branch distribution boards. Conduits for light/power wiring shall be separate.
- 3.2.7 Essential/non-essential/UPS distribution each will have a completely independent and separate distribution system starting from the main, switchboard upto final wiring for each system. As for example, conduit carrying non-essential wiring shall not have essential or UPS wiring. Wiring for essential and UPS supply will have their own conduit system. No mixing of wiring is allowed.
- 3.2.8 Generally, no switchboard will have more than one source of incoming supply. More than one incoming supply will be allowed only at main board with proper safety and interlocking so that only one source can be switched on at a time.
- 3.2.9 Each MDB/DB/Switch Board will have reasonable spare outgoing ways for future expansion.
- 3.2.10 Balancing of 3-phase circuit shall be done.
- 3.2.11 Power and light MCB distribution boards in office/ non-residential building should be of same size irrespective of number of circuits as far as possible in order to get aesthetic look.

### 3.3 Wiring

All flexible copper wires used shall have Class 2 copper conductor satisfying the resistance requirements of NEC 2023 Part 1 Section 17, Annex B.

#### 3.3.1 Submain & Circuit Wiring

- (a) Submain Wiring:  
Submain wiring shall mean the wiring from one main/distribution switchboard to another.
- (b) Circuit Wiring:  
Circuit wiring shall mean the wiring from the distribution board to the 1st tapping point inside the switch box, from where point wiring starts.

#### 3.3.2 Measurement of Submain and Circuit Wiring

- (a) Circuit and submain wiring shall be measured on linear basis along the run of the wiring. The measurement shall include all lengths from end to end of conduit or channel as the case may be, exclusive of interconnections inside the switchboard etc. The increase on account of diversion or slackness shall not be included in the measurement.
- (b) The length of circuit wiring with two wires shall be measured from the distribution board to the

nearest switch box from which the point wiring starts. Looping of switch boxes also will be counted towards circuit wiring, measured along the length of conduit/channel.

- (c) When wires of different circuits are grouped in a single conduit/ channel, the same shall be measured on linear basis depending on the actual number and sizes of wires run.
- (d) Protective (loop earthing) conductors, which are run along the circuit wiring and the submain wiring, shall be measured on linear basis.

**Note:** Conduit carrying submain will not carry circuit/point wiring. Similarly, conduit carrying circuit wiring will not carry submain/point wiring. Conduit carrying point wiring will not carry submain/circuit wiring.

### 3.3.3 Measurement of Other Wiring Work

Except as specified above for point wiring, circuit wiring and submain wiring, other types of wiring shall be measured separately on linear basis along the run of wiring depending on the actual number and sizes of wires run.

## 3.4 Point Wiring

All flexible copper wires used shall have Class 2 copper conductor satisfying the resistance requirements of NEC 2023 Part 1 Section 17, Annex B

### 3.4.1 Definition

A point (other than socket outlet point) shall include all work necessary in complete wiring to the following outlets from the controlling switch or MCB.

- (a) Ceiling rose or connector (in the case of points for ceiling/exhaust fan points, prewired light fittings, and call bells).
- (b) Ceiling rose (in case of pendants except stiff pendants).
- (c) Back plate (in the case of stiff pendants).
- (d) Lamp holder (in the case of goose neck type wall brackets, batten holders and fittings which are not prewired).

### 3.4.2 Scope

Following shall be deemed to be included in point wiring:

- (a) Conduit/channel as the case may be, accessories for the same and wiring cables between the switch box and the point outlet, loop protective earthing of each fan/ light fixture.
- (b) All fixing accessories such as clips, screws, Phil plug, rawl plug etc. as required.
- (c) Metal or PVC switch boxes for control switches, regulators, sockets etc, recessed or surface type, and phenolic laminated sheet covers over the same.
- (d) Outlet boxes, junction boxes, pull-through boxes etc. but excluding metal boxes if any, provided with switchboards for loose wires/conduit terminations.
- (e) Control switch or MCB, as specified.
- (f) 3 pin or 6 pin sockets, ceiling rose or connector as required. (2 pin and 5 pin socket outlets shall not be permitted.)
- (g) Connections to ceiling rose, connector, socket outlet, lamp holder, switch etc.
- (h) Bushed conduit or porcelain tubing where wiring cables pass through wall etc.

**Note:** In areas where false ceiling are provided, termination of wires should be at the fittings. flexible metallic conduits helically wound in galvanized steel from ceiling junction box to the fittings shall be provided duly coupled at both ends with GI couplers. This shall be included within the scope of point wiring.

- (i) Interconnecting wiring between switches within the switch box on the same circuit.
- (j) PVC conduit glands/ double check nuts at conduit terminations.
- (k) Wire termination lugs at all terminations.
- (l) Terminal blocks at switch boards and junction boxes.

### 3.4.3 Measurement

#### (a) Point Wiring (other than socket outlet points)

Unless and otherwise specified, there shall be no linear measurement for point wiring for light points, fan points, exhaust fan points and call bell points. These shall be measured on unit basis by counting, and classified as laid down in 3.4.4.

### 3.4.4 Classification

Points measured under 3.4.3 on unit basis shall be classified as under according to the type of building:

#### (a) Residential Buildings

(i) Group 'A' for point wiring for type I, type II and type III residential quarters and hostels.

(ii) Group 'B' for point wiring for type IV and above type of residential quarters and barracks.

#### (b) Non-residential Buildings

Group 'C' for all types of non-residential buildings such as offices, hospitals, laboratories, educational institutions, libraries etc.

#### (c) For any Other Type of Building

The group under which the points are to be classified shall be decided by the concerned Chief Engineer (Elect.).

### 3.4.5 Point Wiring for Socket Outlet Points

(a) The light plug (6 A) point and power (16 A) point wiring shall be measured on linear basis, from the respective tapping point of live cable, namely, switch box, another socket outlet point, or the sub-distribution board as the case may be, up to the socket outlet.

(b) The metal/PVC box with cover, switch/MCB, socket outlet and other accessories shall be measured and paid as a separate item.

**Note:** There shall normally be no "on the board" light plug point.

(c) The power point outlet may be 16 A/6 A six pin socket outlet, where so specified in the tender documents.

### 3.4.6 Group Control Point Wiring

(a) In the case of points with more than one point controlled by the same switch, such points shall be measured, in parts i.e. (a) from the switch to the first point outlet as one normal point and classified according to 3.4.4, and (b) for the subsequent points as Group Controlled Points. The distance from that outlet to the next one and so on, shall be treated as separate point(s) and classified according to 3.4.4. There shall be no linear measurement for these Group Controlled Points and these shall be measured on unit basis by counting and classified as laid down in 3.4.4.

### 3.4.7 Twin Control Light Point Wiring

(a) A light point controlled by two numbers of two-way switches shall be measured as two points from the fitting to the switches on either side and classified according to 3.4.4.

(b) No recovery shall be made for non-provision of more than one ceiling rose or connector in such cases.

### 3.4.8 Multiple Controlled Call Bell Point Wiring

(a) In the case of call bell points with a single call bell outlet, controlled from more than one place, the points shall be measured in parts i.e.

(i) from the call bell outlet to one of the nearest ceiling roses meant for connection to bell push, treated as one point and classified according to 3.4.4, and

(ii) from that ceiling rose to the next one and so on, shall be treated as separate point(s) and classified according to 3.4.4.

(b) No recovery shall be made for non-provision of more than one ceiling rose or connector for connection to call bell in such cases.

### **3.5 Wiring System**

- 3.5.1 Wiring shall be done only by the looping system. Phase/live conductors shall be looped at the switch box. For point wiring, neutral wire/earth wire looping for the 1st point shall be done in the switch box; and neutral/earth looping of subsequent points will be made from point outlets.
- 3.5.2 In wiring, no joints in wiring will be permitted anywhere, except in switch box or point outlets, where jointing of wires will be allowed with use of suitable connector.
- 3.5.3 The wiring throughout the installation shall be such that there is no break in the neutral wire except in the form of linked switchgear.
- 3.5.4 Light, fans and call bells shall be wired in the 'lighting' circuits. 15A/16A socket outlets and other power outlets shall be wired in the 'power' circuits. 5A/6A socket outlets shall also be wired in the 'power' circuit both in residential as well as non- residential buildings.
- 3.5.5 Colour Coding of Wiring:  
Following colour coding shall be followed in wiring:  
Phase : Red/Yellow/Blue.(Three phase wiring)  
Live : Red (Single phase wiring)  
Neutral : Black  
Earth : Yellow/Green.
- 3.5.6 Termination of Circuit into Switchboard  
Circuit will consist of phase/neutral/earth wire. Circuit will terminate in a switch board (first tapping point, where from point wiring starts) in following manner:  
Phase wire terminated in phase connector. Neutral wire terminated in neutral connector. Earth wire terminated in earth connector.  
The switchboard will have phase, neutral and earth terminal connector blocks to receive phase/neutral/ earth wire. See Fig 3.

### **3.6 Run of Wiring**

- 3.6.1 The type of wiring shall be as specified in the tender documents namely, surface conduit/recessed conduit, steel/PVC, channel.
- 3.6.2 Surface wiring shall run as far as possible along the walls and ceiling, so as to be easily accessible for inspection.
- 3.6.3 Above false ceiling, in no case, open wiring shall be allowed. Wiring will be done in recessed conduit or surface steel conduit.
- 3.6.4 In recessed conduit system, routes of conduit will be planned, so that various inspection boxes provided don't present a shabby look. Such boxes can be provided 5 mm above plaster level, and they can be covered with plaster of Paris with marking of junction boxes.
- 3.6.5 Where number of electrical services like electrical wiring, telephone wiring, computer cabling, pass through corridors, it may be proper to plan such service with properly designed aluminium/PVC channels duly covered by a false ceiling, so that subsequently such service can be maintained and additional cables can be provided.
- 3.6.6 Generally, conduits for wiring will not be taken in floor slabs. When it is unavoidable special precaution to be taken to provide floor channels with provision for safety and maintenance. Alternatively floor trunking (raceways) / false flooring can be provided.

### **3.7 Passing through Walls or Floors**

- 3.7.1 When wiring cables are to pass through a wall, these shall be taken through a protection (steel/ PVC) pipe or porcelain tube of suitable size such that they pass through in a straight line without twist or cross in them on either porcelain, PVC or other approved material.
- 3.7.2 All floor openings for carrying any wiring shall be suitably sealed after installation.

### **3.8 Joints in Wiring**

- 3.8.1 No bare conductor in phase and/or neutral or twisted joints in phase, neutral, and/ or protective conductors in wiring shall be permitted.
- 3.8.2 There shall be no joints in the through-runs of cables. If the length of final circuit or submain is more

than the length of a standard coil, thus necessitating a through joint, such joints shall be made by means of approved mechanical connectors in suitable junction boxes.

3.8.3 Termination of multistranded conductors shall be done using suitable crimping type thimbles.

### **3.9 Ratings of Outlets**

(to be adopted for design).

3.9.1 LED fittings shall be used in the buildings and the rated capacity shall be as per actuals subject to “each circuit shall not have more than 800 W connected load or more than 20 points whichever is less”.

3.9.2 Conventional Ceiling fans shall be rated at 60W and BLDC fans shall be rated as per the actuals. Exhaust fans, fluorescent tubes, compact fluorescent tubes, HPMV lamps, HPSV lamps, CFL fittings etc. shall be rated according to their capacity. Control gear losses shall also be considered as applicable.

3.9.3 6A and 16A socket outlet points shall be rated at 100W and 1000W respectively, unless the actual values of loads are specified.

### **3.10 Capacity of Circuits**

3.10.1 Lighting circuit shall feed light/fan/call bell points. Each circuit shall not have more than 800 W connected load or more than 20 points whichever is less as because of introduction of LED lights, load on lighting circuit gets reduced drastically.

3.10.2 Power circuit in non-residential building will have only one outlet per circuit. However in non-residential building for computer points 3 nos. 6A outlet sockets can be feed through power circuit.

3.10.3 Each power circuit in residential building can feed following outlets:

(a) Not more than 2 Nos. 16A outlets.

(b) Not more than 3 Nos. 6A outlets.

(c) Not more than 1 No.16A and 2 Nos. 6A outlets.

(d) Independent circuit each to feed Geyser, AC Outlet and Kitchen oven, washing machine outlets

3.10.4 Load more than 1 KW shall be controlled by suitably rated MCB and cable size shall be decided as per calculations.

3.10.5 Power Wiring with Bus Trunking

It is permitted to meet large-scale power requirement in a hall, or floor, with use of single phase or 3 phase bus bars running inside a metal enclosure. This will be provided with careful design and use of factory fabricated bus-trunking of reputed make, conforming to relevant BIS standards and with standard accessories like End feed unit, tap off with necessary safety features like over current, short-circuit and earth fault protection. Such trunking will be of specified breaking KA rating.

### **3.11 Socket Outlets**

3.11.1 Socket outlets modular type shall be 6A 3 pin, 16 Amp 3 pin or 16/6 Amp 6 pin. 5 pin socket outlets will not be permitted.

The third pin shall be connected to earth through protective earthing conductor. 2 pin or 5 pin sockets shall not be permitted to be used.

3.11.2 Conductors connecting electrical appliances with socket outlets shall be of flexible type with an protective earthing conductor for connection to the earth terminal of plug and the metallic body of the electrical appliance.

3.11.3 Sockets for the power outlets of rating above 1KW shall be of suitable rating modular switch/ socket configuration with controlling MCB.

3.11.4 Where specified, shutter type (interlocking type) of sockets shall be used.

3.11.5 Every socket outlet shall be controlled by a switch or MCB, as specified. The control switch/MCB shall be connected on the ‘live’ side of the line.

3.11.6 6A and 16A socket outlets shall be installed at the following positions, unless otherwise specified.

(a) Non-residential buildings –

- (i) 6A socket outlet: 110 cm above floor level.
- (ii) 16A socket outlet: 23 cm/ 110 cm above floor level.
- (b) Kitchen/ Pantry:  
6A/ 16A socket outlet – 23 cm above working platform and away from the likely positions of stove and sink.
- (c) Bathroom:  
6A socket outlet: Socket outlet for portable appliances like hair dryer, shaver etc. to be provided adjacent to wash basin/ mirror at 110 cm height above floor level.  
For Geyser:  
16A MCB in modular switch box arrangement be provided in bathroom at 110 cm height, adjacent to switchboard (for light and exhaust fan) with socket outlet at minimum 2mt. height from floor level and at least 60 cm. away from shower head adjacent to geyser (within 30 cm).

OR

16A MCB in modular box arrangement be provided in bathroom at 110 cm height at suitable location near door, with socket outlet at minimum 2mt. height from floor level and at least 60 cm. away from shower head adjacent to geyser (within 30 cm).

- (d) Rooms in residences
    - (i) 6A socket outlet: 70 cm above floor level on bed side(s)
    - (ii) 6A socket outlet: for other locations, 23 cm/110 cm above floor level, or any other level in special cases as desired by the Engineer-in-charge.
    - (iii) 16A socket outlet –23 cm/110 cm above floor level, or any other level in special cases as desired by the Engineer-in-charge.
- 3.11.7 Unless and otherwise specified, the control switches for the 6A and 16A socket outlets shall be kept along with the socket outlets.

### 3.12 Cables

3.12.1 Copper conductor cable only will be used for submain/ circuit/ point wiring.

3.12.2 Minimum size of wiring:

Light Wiring	:	1.5 sq.mm.
Power Wiring	:	4.0 sq.mm.
Power circuit rated	:	More than 1 KW, Size as per calculation.

3.12.3 Insulation : Copper conductor cable shall be PVC insulated conforming to BIS Specification

3.12.4 Multi stranded : Cables are permitted to be used. However, proper termination on the ends with lugs/ thimbles should be used.

### 3.13 Flexible Cable

3.13.1 Conductor of flexible cables shall be of copper. The cross-sectional area of conductor for flexible cable shall be as per design.

3.13.2 Only 3 core flexible cables shall be used for connecting single-phase appliances.

3.13.3 Unless the flexible cables are mechanically protected by armour, or tough rubber, or PVC sheath, these shall not be used in workshops and other places where they are liable to mechanical damage.

3.13.4 Flexible cable connection to bell push from ceiling rose shall be taken through steel conduit/metallic casing and capping.

### 3.14 Wiring Accessories

#### 3.14.1 Control Switches for Point

- (a) Control switches (single pole switch) carrying not more than 16A shall be modular type. The switch shall be 'On' when the knob is down.
- (b) (i) In type II & III quarters, Barracks & school buildings (except principal's & staff rooms) etc. Modular type switches and sockets should be used.

- (ii) Modular type switches and sockets to be provided for remaining types of buildings i.e. in all types of remaining non-residential buildings & residential buildings of type IV & above & Transit hostel or as may be decided by the Architect/ user department.
- (c) It is recommended to provide MCB in Modular type boxes with controlling MCB for window type, split type AC units, geysers etc. The location of the controlling MCB and related socket should can be at separate location depending upon type of gadget. For example, in case of geyser/ split AC the socket can be near the geyser/ indoor split unit and switch/ controlling MCB can be at different location at approachable height.

**Note:** The advisory issued vide No. DG/SE(E)TAS/SPECIFICATIONS/06 dated 30.11.2021 as enclosed at Chapter 17 – Appendix-L to be referred to.

### 3.14.2 Specification of Modular Switches and socket

The modular switch shall be as per following/ have features mentioned below: -

- Suitable for 240V, AC, with normal gap constructions, Flush type, Screw type terminal, IP20
- Current carrying plastic parts of Nylon (PA6) with glass fibres up to 16A
- Non-Flammable insulating parts & very high Insulating resistance after Humidity test.
- Marked with IS 3854:1997
- Snap fit with Modular Plates very easy to install
- Arrow marking for correct orientation with plate.
- Double rocker mechanism to prevent visible spark.
- Bimetal Silver contact tips for less spark & longer life.
- Fire retardant and UV stabilized.

The modular sockets shall be as per following/ have features mentioned below:-

- 240V, AC, Flush type, Screw type terminal, Shuttered.
- Polycarbonate material thickness ~1.5 mm to 2.5 mm
- Non-Flammable insulating parts & very high Insulating resistance after Humidity test.
- 6A, 6/16A Socket market with ISI, as per IS1293:2019
- Snap fit with Modular Plates easy to install
- Brass current carrying parts.
- Fire retardant and UV stabilized.

### 3.14.3 Switch Box

- (a) Switch box shall be hot dip galvanized, factory fabricated, suitable in size for surface/ recess mounting and suitable in size for accommodating the required number of switches and accessories (where required to be used for applications other than modular switches/ sockets).
- (b) Switch box also can be of non-metallic material. The technical sanctioning authority will approve specified makes of reputed quality and specifications.

### 3.14.4 Switch Box Covers (for application other than modular type)

Phenolic laminated sheets of approved shade shall be used for switch box covers. These shall be of 3 mm thick synthetic phenolic resin bonded laminated sheet as base material and conforming to grade P- I of IS 2036: 1995.

**Note:** Specification for switch boxes is covered in the chapters on the various types of wiring.

### 3.14.5 Ceiling Rose

- (a) A ceiling rose shall not be used on a circuit, the voltage of which normally exceeds 250V.
- (b) Only one flexible cord shall be connected to a ceiling rose. Specially designed ceiling roses shall be used for multiple pendants.
- (c) A ceiling rose shall not embody fuse terminal as an integral part of it.

### 3.14.6 Lamp Holders

#### 3.14.7

- (a) Lamp holders may be batten, angle, pendant or bracket holder type as required. The holder shall be made of brass/ ABS Plastic material/ Bakelite (ISI marked) and shall be rigid enough to maintain shape on application of a nominal external pressure. There should be sufficient threading for fixing the base to the lamp holder part so that they do not open out during attention to the lamp or shade.
- (b) Lamp holders for use on brackets and the like shall have not less than 1.3 cm nipple, and all those for use with flexible pendant shall be provided with cord grips.
- (c) All lamp holders shall be provided with shade carriers.
- (d) Where centre contact Edison Screw lamp holders are used, the outer or screw contact shall be connected to the 'middle wire', or the neutral conductor of the circuit.

#### 3.14.8 Fittings

- (a) Types: The type of fittings shall be as specified in tender documents. The fitting proposed shall be compliant to the related Bureau of Indian Standards (BIS) as applicable, including LED fittings.
- (b) Indoor Type Fittings
  - (i) Where conductors are required to be drawn through tube or channel leading to the fitting, the tube or channel must be free from sharp angles or projecting edge, and of such size as will enable them to be wired with the conductors used for the final circuit without removing the braiding or sheathing. As far as possible all such tubes or channels should be of sufficient size to permit looping back.
  - (ii) Wires used within prewired fittings shall be flexible with PVC insulation and 14/0.193 mm (minimum) copper conductors. The leads shall be terminated on built-in-terminal block, ceiling rose or connector, as required.
  - (iii) Fittings using discharge lamps shall be complete with power factor correction capacitors, either integrally or externally. An earth terminal with suitable marking shall be provided for each fitting for discharge lamps.
  - (iv) Fittings shall be installed such that the lamp is at a height of 2.4m above floor level, unless otherwise directed by the Engineer-in-charge.
  - (v) Fittings made of CRCA shall be phosphatized and powder/epoxy painted. For coastal areas and humid area like toilets, kitchen, for prolonging the life of such fittings, corrosion free materials like engineering plastic, aluminium, stainless steel etc. should be used.
- (c) Outdoor Fittings

Outdoor fittings shall have suitable IP protection. It is preferable that street light fittings are of cast aluminium body of minimum IP 65, for reducing recurring maintenance cost and improved performance. Where ever required IP 66 fittings also can be provided for reducing maintenance frequency and cost.

Other fittings, which are not available with tested IP 65/54 protection, can be properly fabricated with weatherproof features, proper gasketing etc. As far as possible corrosion free material like cast aluminium, stainless steel, engineering plastics may be used for fabrication of such fittings, to prolong life of such fittings. There should not be any exposed wiring in such outdoor fittings.

### 3.15 Attachment of Fittings and Accessories

#### 3.15.1 Conduit Wiring System

- (a) All accessories like switches, socket outlets, call bell pushes and regulators shall be fixed in flush pattern inside the switch/regulator boxes. Accessories like ceiling roses, brackets, batten holders etc. shall be fixed on outlet boxes. The fan regulators may also be fixed on outlet boxes, if so directed by the Engineer-in-charge.
- (b) Aluminium alloy or cadmium plated iron screws shall be used to fix the accessories to their bases.
- (c) The switch box/regulator box shall normally be mounted with their bottom at 1.1 m from floor level, unless otherwise directed by the Engineer-in-charge.

### 3.15.2 Fixing to Walls and Ceiling

- (a) Wooden plugs for fixing to wall/ceiling will not be allowed. Fixing will be done with the help of PVC sleeves/Rowel plugs/ dash fasteners as required.
- (b) Drilling of holes shall be done by drilling machines only. No manual drilling of hole will be allowed.

### 3.16 Fans, Regulators and Clamps

#### 3.16.1 Ceiling Fans

- (a) Ceiling fans including their suspension shall conform to relevant Indian Standards.
- (b) The capacity of a ceiling fan to meet the requirement of a room with the longer dimension D meters should be about  $55 D \text{ m}^3/\text{min}$ .
- (c) The height of fan blades above the floor should be  $(3H + W)/4$ , where H is the height of the room, and W is the height of the work plane.
- (d) The minimum distance between fan blades and the ceiling should be about 0.3 meters.
- (e) When actual ventilated zone does not cover the entire room area, then optimum size of ceiling fan should be chosen based on the actual usable area of the room, rather than the total floor area of the room.
- (f) The number of fans and the optimum sizes for rooms of different dimensions are given in the table 3.1:

**Table 3.1**

**OPTIMUM SIZE/NUMBER OF FANS FOR ROOMS OF DIFFERENT SIZES**

Room Width m	Room Length										
	4m	5m	6m	7m	8m	9m	10m	11m	12m	14m	16m
(1)	(2)	(3)	(4)	(5)	(6)	(7)	(8)	(9)	(10)	(11)	(12)
3	1200/1	1400/1	1500/1	1050/2	1200/2	1400/2	1400/2	1400/2	1200/3	1400/3	1400/3
4	1200/1	1400/1	1200/2	1200/2	1200/2	1400/2	1400/2	1500/2	1200/3	1400/3	1500/3
5	1400/1	1400/1	1400/2	1400/2	1400/2	1400/2	1400/2	1500/2	1400/3	1400/3	1500/3
6	1200/2	1400/2	900/4	1050/4	1200/4	1400/4	1400/4	1500/4	1200/6	1400/6	1500/6
7	1200/2	1400/2	1050/4	1050/4	1200/4	1400/4	1400/4	1500/4	1200/6	1400/6	1500/6
8	1200/2	1400/2	1200/4	1200/4	1200/4	1400/4	1400/4	1500/4	1200/6	1400/6	1500/6
9	1400/2	1400/2	1400/4	1400/4	1400/4	1400/4	1400/4	1500/4	1400/6	1400/6	1500/6
10	1400/2	1400/2	1400/4	1400/4	1400/4	1400/4	1400/4	1500/4	1400/6	1400/6	1500/6
11	1500/2	1500/2	1500/4	1500/4	1500/4	1500/4	1500/4	1500/4	1500/6	1500/6	1500/6
12	1200/3	1400/3	1200/6	1200/6	1200/6	1400/6	1400/6	1500/6	1200/7	1400/9	1400/9
13	1400/3	1400/3	1200/6	1200/6	1200/6	1400/6	1400/6	1500/6	1400/9	1400/9	1500/9
14	1400/3	1400/3	1400/6	1400/6	1400/6	1400/6	1400/6	1500/6	1400/9	1400/9	1500/9

**Note:** This table is indicative only. Case specific design should be done by field officers based on site conditions & constraints.

- (g) Performance values of fans as per Table below and other test parameters such as speed, input watt, power factor etc. shall be corresponding to the highest speed achievable from remote control or regulator. Any other devices or speed regulation features, if provided, shall be suitably set to achieve the highest speed. (*refer IS 374:2019, Amendment-1-2022*).  
Energy Efficient fans with BEE 3–5-star rating or complying with IS 374: 1979, shall be used. The

minimum service value of fans shall be 3.5 m<sup>3</sup>/min/W and air delivery 200 m<sup>3</sup>/min. The values of service factor and air delivery for ceiling fans with 1200 mm sweep are given in the table 3.2:

**Table 3.2**  
**Performance Value of Fans**

SI No. (1)	Fan Size mm (2)	Minimum Air Delivery m <sup>3</sup> /min (3)	Minimum Service Value m <sup>3</sup> /min/W (4)
1.	600	100	1.5
2.	> 600 and ≤ 750	115	1.7
3.	> 750 and ≤ 900	130	3.1
4.	> 900 and ≤ 1 050	150	3.1
5.	> 1 050 and ≤ 1 200	210	4.0
6.	> 1 200 and ≤ 1 320	220	4.0
7.	> 1 320 and ≤ 1 400	245	4.1
8.	> 1 400 and ≤ 1 500	270	4.3

**NOTES:**

- (i) Air delivery values are on the basis of air velocity measurement up to 15 m/min.
  - (ii) However In Hostel, Barracks a, Number of fans shall also be decided taken into account the location of furniture layout etc.
- (h) Two module Step type electronic regulators should be used instead of resistance type regulators for controlling speed of fans
  - (i) All ceiling fans shall be wired to ceiling roses or to special connector boxes, and suspended from hooks or shackles, with insulators between hooks and suspension rods. There shall be no joint in the suspension rod.
  - (j) For wooden or steel joists and beams, the suspension shall consist of GI flat of size not less than 40 mm x 6 mm, secured on the sides of the joists or beams by means of two coach screws of size not less than 5 cm for each flat. Where there is space above the beam, a through-bolt of size not less than 1.5 cm dia, shall be placed above the beam from which the flats are suspended. In the latter case, the flats shall be secured from movements by means of another bolt and nut at the bottom of the beam. A hook consisting of MS rod of size not less than 1.5 cm dia shall be inserted between the MS flat through oval holes on their sides. Alternatively, the flats may be bent inwards to hold tightly between them by means of a bolt and nut, a hook of 'S' form.
  - (k) In the case of 'I' beams, flats shall be shaped suitably to catch the flanges and shall be held together by means of a long bolt and nut.
  - (l) For concrete roofs, a 12 mm dia. MS rod in the shape of 'U' with their vertical legs bent horizontally at the top at least 19 cm on either side, and bound to the top reinforcement of the roof shall be used, as shown in Fig. 4.
  - (m) In buildings with concrete roofs having a low ceiling height, where the fan clamp mentioned under sub-clause (v) above cannot be used, or wherever specified, recessed type fan clamp inside metallic box, as shown in Fig. 5 shall be used.
  - (n) Canopies on top of suspension rod shall effectively hide the suspension.
  - (o) The leading in wire shall be of nominal cross-sectional area not less than 1.5 sq. mm. and shall be protected from abrasion.

- (p) Unless otherwise specified, all ceiling fans shall be hung 2.75 m above the floor.
- (q) In the case of measurement of extra down rod for ceiling fan including wiring, the same shall be measured in units of 10 cm. Any length less than 5 cm shall be ignored.
- (r) The wiring of extra down rod shall be paid as supplying and drawing cable in existing conduit.

### 3.16.2 Exhaust Fans

- (a) Exhaust fans shall conform to relevant Indian Standards.
- (b) Exhaust fans shall be erected at the places indicated by the Engineer-in-charge. For fixing an exhaust fan, a circular opening shall be provided in the wall to suit the size of the frame, which shall be fixed by means of rag bolts embedded in the wall. The hole shall be neatly plastered to the original finish of the wall. The exhaust fan shall be connected to the exhaust fan point, which shall be wired as near to the opening as possible, by means of a flexible cord, care being taken to see that the blades rotate in the proper direction.
- (c) Exhaust fans for installation in corrosive atmosphere, shall be painted with special PVC paint or chlorinated rubber paint.
- (d) Installation of exhaust fans in kitchens, dark rooms and such other special locations need careful consideration; any special provisions needed shall be specified.

### 3.16.3 Regulators

The metallic body of regulators of ceiling fans/exhaust fans shall be connected to earth by protective conductor.

## 3.17 Marking of Switch Boards

### 3.17.1 Schematic Diagram

First a comprehensive schematic diagram for each building is to be prepared, starting from Main LT Panel, rising main, submain boards, DBs, etc. and the manner in which they are connected. This will include essential, non-essential and UPS systems. Sizes of interconnecting main/submain cables shall be indicated.

### 3.17.2 Marking of each Main Board

Each main board/submain board shall be marked indicating rating of each incoming/ outgoing switch and the details of load/area it feeds. Detail/size of incoming and outgoing cable also shall be marked indicating from where the incoming cable has originated.

### 3.17.3 Marking of Distribution Board

Each Distribution Board shall be marked indicating detail of incoming switch (Size of cable and from where it is fed) and marking of each outgoing MCB indicating the area it feeds. Suitable marking sticker will be suitably fixed to indicate such details.

### 3.17.4 Marking of Power/Light DBs

Power/light DBs shall be marked 'P' and 'L' respectively.

### 3.17.5 Marking for Non-essential/Essential/UPS/Switch Boards

Each switchboard shall be marked essential/non-essential/UPS to indicate the nature of such switchboards.

### 3.17.6 Marking of Main Earthing Terminal

Main Earthing terminals in main/submain switchboard shall be permanently marked, as "Safety Earth – Don't Remove".

## 3.18 LT Distribution Switchgear

Only following type switchboards will be used:

### 3.18.1 Main/Submain switchboard of cubicle type.

### 3.18.2 DBs shall have incoming and outgoing terminal blocks with factory pre-wiring up to outgoing terminal blocks having phase/neutral/Earth terminal block for each circuit. This is to minimise chance of loose wiring which is a potential fire hazard. Conventional DBs of reputed makes with factory fabricated loose wire box with terminal blocks can also be used with the approval of technical sanctioning authority/NIT authority in addition to pre wired DBs. (See fig 8)

### 3.18.3 Specially designed switchboards.

Also specially designed switchboards can be used with detailed specification and fabrication drawings approved by the technical sanctioning authority.

### 3.18.4 Specifications of Cubicle Panel given in Chapter 7.

## 3.19 Location of Switchboards

3.19.1 Switchboards are to be located in common areas like corridors, lobby etc. and not to be located in locked room.

3.19.2 Switchboard shall be located only in dry situation and in well-ventilated space. They shall not be placed in the vicinity of storage battery or exposed to chemical fume.

3.19.3 Switchboards shall not be erected above gas stove, or sinks or within 2.5 meter of any washing unit in washing rooms of laundrings or in the bath rooms, toilets, or kitchen.

3.19.4 As far as possible main boards shall not be located in basement. Such main boards can be located in ground floor.

3.19.5 It is preferable to locate floor main boards in rising main shafts of adequate size, with steel doors (having ventilation) or in suitable room.

3.19.6 Similarly, DBs can be in suitable niches in corridor walls having doors.

3.19.7 Locating main boards under staircase or standing open in corridor is not a desirable practice, besides being highly unesthetic.

3.19.8 The main switchboard, which receives power to the building, should be invariably located in a switch room, having round the clock access, for emergency attendance to the switchboard.

## 3.20 Guidelines for Planning Residential Areas

### 3.20.1 U.G. System of Power Distribution, Street Lighting, Telephone Cabling and TV Cabling

For long-term economical maintenance, better reliability of service, safety, protection against heavy rains, storm, wind etc. and aesthetics, underground cable system will be generally followed. Also considering the high cost of land, underground system results in better economic utilization of land area, otherwise substantial land route has to be earmarked for overhead lines.

3.20.2 Efficient working of street lights and staircase lighting is required for security of the colony and safety and convenience of the residents. Therefore, adequate street lighting, staircase lighting is to be provided. Generally back lanes of residential blocks remain dark. Such areas are also to be covered by basic street lighting for security.

### 3.20.3 Kitchen

(a) Exhaust fans opening with one point outlet to be provided irrespective of yardstick of provision of exhaust fans.

(b) In addition to one 16 A 6-pin power outlet for kitchen, one 3 pin 6 Amp. outlet to be provided for water filter.

### 3.20.4 Washing Machine

Location to be finalized in consultation with the Architect. A power outlet plus water supply/drainage to be coordinated with Architect/Civil Engineer.

### 3.20.5 Meter Board

(For a Block of Quarters)

Generally, for a block of quarters of 2/3/4 storied, electric supply for each block is received in a meter board, where a cubicle meter panel is provided with system of power distribution to each quarter. (Chapter – 19 See Fig. 6)

At present such meter boards are invariably located under staircase. This is not a desirable practice from technical/aesthetic viewpoint.

It is technically desirable to coordinate with Architect to provide separate meter room for each block

of quarters or a number of blocks.

### 3.20.6 Stair Case Lighting

Stair case lighting is to be treated as an extension of street lighting, for security and convenience of the residents. LED light fitting for staircase lighting may be provided to reduce load. Incandescent stair case lighting and bulk head fittings should not be provided, in view of excessive energy consumption and low burning hours.

### 3.20.7 Emergency Electric Supply

For ensuring essential water supply and security lighting, a D.G. set to be provided for each colony to take care of water supply pump set, sewerage pump set, street lighting and essential load requirement of buildings like CGHS Dispensary, Community Centre etc.

### 3.20.8 Fittings

Subject to limit of yardstick of fittings for various types of quarters following guidelines to be provided:

- (a) Every room to be provided with one LED batten fitting for energy saving.
- (b) Kitchen to be provided with a LED batten fitting.
- (c) Incandescent bulkhead fittings not to be used.
- (d) Quality fittings of reputed make to be used.
- (e) Colour temperature of LED Lights to be used should be specified in the NIT.

### 3.20.9 Main Board of Each Quarter

It shall be MCB type with provision of ELCB with the incoming MCB. It shall be located in a niche with ventilated door cover, in the room connecting to the entry of the quarter. MCB DB shall be double door type.

### 3.20.10 Corrosion Free Fittings

Coastal areas and humid areas like kitchen, toilet are subject to corrosion, which substantially reduces the useful life of such fittings, besides giving an ugly look on account of rusting.

Therefore, for coastal areas, and other humid areas corrosion free type of fittings (like aluminium, stainless steel, engineering plastic) should be used, for ensuring long life of such fittings and to achieve life cycle economy, after taking into account recurring expenditure on account of painting of fittings.

### 3.20.11 Telephone Wiring

Telephone wiring is to be provided for each quarter. Such telephone wiring to be brought to a tag-block at a suitable point in ground floor. Provisions shall be kept for suitable entry-pipe for laying incoming telephone cable. The number of telephone points shall be as per scale of amenities for electrical installation in general pool residential accommodation.

### 3.20.12 TV Cabling

Internal TV cabling shall be provided,. Similarly, from suitable point at ground floor, TV cabling shall be provided. With use of suitable splitters, such TV cabling to be connected to each quarter. The number of TV points shall be as per scale of amenities for electrical installation in general pool residential accommodation.

### 3.20.13 Lighting for Parks

Colonies are provided with parks. Such parks should be provided with adequate lights to include area lights, pathway lights etc. so that the parks can be effectively used by the residents and they remain secure during night time.

### 3.20.14 External Pipe Network for Laying Telephone and TV Cabling for the Colony

Starting from a suitable room, pipe network may be provided to lay telephones/TV cables for the colony. Suitable road cross pipe and manholes to be provided for drawing such cables and their maintenance.

### 3.20.15 Preliminary Estimate to Take Care of Telephone/TV Cabling in a Colony

At present, such services are provided in a very crude manner making use of existing poles and hanging cables. Apart from making colonies shabby, such services are subject to damages and unsatisfactory service. Therefore, preliminary estimate should provide for such TV/Telephone cabling for the colony.

### 3.20.16 Other Allied Services

Modern residential colonies require support services like CCTV (for Gate and house security), intercom system, basic security system etc. for the safety and convenience of the residents. Therefore, preliminary estimate should provide for basic provisions for such safety/security systems. Most of these services pay for themselves within 3 / 4 years of installation, besides providing security, which sometimes amount to life saving instances.

## 3.21 Guidelines for Planning Office Buildings

3.21.1 The main objective is to provide safe, efficient, reliable electricity with measures to avoid possible fire hazards, which calls for sound detailed designing and use of quality equipment and materials executed with sound workmanship and supervision.

3.21.2 All control LT Panels, controlling power supply to the entire building will be located in a centralized room, from where centralized control and monitoring of the entire power supply system can be made.

3.21.3 Earth fault protection shall be provided for each individual building at the LT receiving point i.e. Main LT Panel. RCD/ RCCB shall be used as per the provisions of CEA (Measures related to Safety and Electric supply) Regulations.

3.21.4 Office buildings are prone to fire hazard during night hours. Therefore, after office hours, all the LT Panels should be switched off. Based on need of the building, only the specified LT panel to be kept 'ON' which feed the loads during night hours. Such panel, called common service panel, may feed following loads, which are normally used after office hours: -

- (a) Some specified lifts.
- (b) Staircase/ Corridor/ Compound light.
- (c) Fire protection loads.
- (d) Pump Sets.
- (e) Other loads which are kept 'ON' after office hours.

### 3.21.5 Reliability of Power Supply

Minimum two transformers to be provided to provide certain redundancy.

3.21.6 It is preferable to plan for a separate service building, to combine all electrical and mechanical services of the building, so that the services can be maintained comprehensively at a lower cost and also reducing the overall area requirement. Such service building can combine electric sub-station, DG Sets, UPS, Air- conditioning Plant, water supply pump sets, etc.

3.21.7 While planning, maintainability of various services to be ensured, like providing facilities like access, approachability of various equipment, maintenance space etc.

### 3.22 Mandatory test for wire :

This Mandatory Test is applicable for original works only (original Works means all new constructions, site preparation, additions and alterations, special repairs to newly purchased or previously abandoned buildings or structures, including re-modelling or replacement).

The Acceptance Test as mentioned in IS 694-2010 (Reaffirmed 2020) shall constitute the mandatory test for wires non-metallic rigid conduit :

Acceptance tests:

- (a) Annealing test (for copper)
- (b) Tensile test (for aluminium)
- (c) Wrapping test (for aluminium)
- (d) Conductor resistance test
- (e) Test for thickness of insulation
- (f) Tensile strength and elongation at break of insulation
- (g) Insulation resistance test
- (h) High voltage test or spark test
- (i) Flammability test
- (j) Oxygen index test
- (k) Test for temperature index
- (l) Test for halogen acid gas evaluation
- (m) Test for smoke density rating
- (n) Persulphate test (for tinned copper conductor cable only)

## CHAPTER 4

# METALLIC CONDUIT WIRING SYSTEM

### 4.1 Scope

This chapter covers the detailed requirements for wiring work in metallic conduits. This chapter covers both surface and recessed types of works.

### 4.2 Application

**4.2.1** Recessed conduit is suitable generally for all applications. Surface conduit work may be adopted in places like workshops, plant rooms, pump rooms, wiring above false ceiling/below false flooring, and at locations where recessed work may not be possible to be done. The type of work, viz. surface or recessed, shall be as specified in the respective works.

**4.2.2** Flexible conduits may only be permitted for interconnections between switchgear, DBs and conduit terminations in wall.

### 4.3 Material

#### 4.3.1 Conduits

- (a) All rigid conduit pipes shall be of steel and be ISI marked (IS 9537: part 2 :1981 (reaffirmed 2017). The wall thickness shall be not less than 1.6 mm (16 SWG) for conduits upto 32 mm dia and not less than 2 mm (14 SWG) for conduits above 32 mm dia. The wall thickness of the steel conduit shall be as per relevant IS.
- (b) These shall be solid drawn or reamed by welding and finished with galvanized or stove enamelled surface.
- (c) The maximum number of PVC insulated cables conforming to IS 694: 2018 that can be drawn in one conduit is given size wise in Table 4.1 below, and the number of cables per conduit shall not be exceeded. Conduit sizes shall be selected accordingly in each run.
- (d) No steel conduit less than 20 mm in diameter shall be used.

#### 4.3.2 Conduit Accessories

- (a) The conduit wiring system shall be complete in all respects, including their accessories.
- (b) All conduit accessories shall be of threaded type, and under no circumstances pin grip type or clamp grip type accessories shall be used.
- (c) Bends, couplers etc. shall be solid type in recessed type of works and may be solid or inspection type as required, in surface type of works.
- (d)
  - (i) Saddles for surface conduit work on wall shall not be less than 0.55 mm (24 gauges) for conduits up to 25 mm dia and not less than 0.9 mm (20 gauges) for larger diameter. The corresponding widths shall be 19 mm & 25 mm.
  - (ii) The minimum width and the thickness of girder clips used for fixing conduits to steel joists, and clamps shall be as per Table 4.2 below.
- (e) All accessories of steel conduit like junction box, bend etc. shall be ISI marked only (BIS 14768 Part 2 : 2003 Conduit fittings and BIS 3837:1976, Reaffirmed 2006, Accessories for Rigid Steel Conduit).
- (f) For the connections between the ceiling to the fitting (in the areas having false ceiling), flexible GI conduit with helical construction along GI couplers on both the ends shall be used.

#### 4.3.3 Outlets

- (a) The switch box or regulator box shall be made of metal on all sides, except on the front. In the case of cast boxes, the wall thickness shall be at least 3 mm and in case of welded mild steel sheet boxes, the wall thickness shall not be less than 1.2 mm (18 gauge) for boxes upto a size of 20 cm x 30 cm, and above this size 1.6 mm (16 gauge) thick MS boxes shall be used. The metallic boxes shall be duly painted with anticorrosive paint before erection as per chapter 15 of these Specifications. The modular switch boxes shall be of required number of modules, made of GI sheet steel and compliant to relevant BIS.
- (b) Where a large number of control switches and/or fan regulators are required to be installed at one

place, these shall be installed in more than one outlet box adjacent to each other for ease of maintenance.

- (c) An earth terminal with stud and 2 metal washers and terminal block shall be provided in each MS box for termination of protective conductors and for connection to socket outlet/metallic body of fan regulator etc.
- (d) A metal strip shall be welded/screwed, to the metal box as support if tumbler type of control switches, sockets and/or fan regulators in flush pattern.
- (e) Clear depth of the box shall not be less than 60 mm and this shall be increased suitably to accommodate mounting of fan regulators in flush pattern.
- (f) The fan regulators can also be mounted on the switch box covers, if so stipulated in the tender specifications, or if so directed by the Engineer-in-charge.
- (g) Except where otherwise stated, 3 mm thick phenolic laminated sheets as per clause 3.14(c) shall be fixed on the front with brass screws, or aluminium alloy/ cadmium plated iron screws as approved by the Engineer-in-charge.

#### **4.4 Installation**

##### **4.4.1 Common Aspects for Recessed and Surface Conduit Works**

- (a) Conduit Joints
  - (i) The conduit work of each circuit or section shall be completed before the cables are drawn in.
  - (ii) Conduit pipes shall be joined by means of screwed couplers and screwed accessories only. Threads on conduit pipes in all cases shall be between 13 mm to 19 mm long, sufficient to accommodate pipes to full threaded portion of couplers or accessories.
  - (iii) Cut ends of conduit pipes shall have no sharp edges, nor any burrs left to avoid damage to the insulation of the conductors while pulling them through such pipes.
  - (iv) The Engineer-in-charge, with a view to ensuring that the above provision has been carried out, may require that the separate lengths of conduit etc., after they have been prepared, shall be submitted for inspection before being fixed.
  - (v) No bare threaded portion of conduit pipe shall be allowed, unless such bare threaded portion is treated with anticorrosive preservative or covered with approved plastic compound.
- (b) Bends in Conduit
  - (i) All necessary bends in the system, including diversion, shall be done either by neatly bending the pipes without cracking with a bending radius of not less than 7.5 cm, or alternatively, by inserting suitable solid or inspection type normal bends, elbows or similar fittings, or by fixing cast iron inspection boxes, whichever is most suitable.
  - (ii) No length of conduit shall have more than the equivalent of four quarter bends from outlet to outlet.
  - (iii) Conduit fittings shall be avoided as far as possible on conduit system exposed to weather. Where necessary, solid type fittings shall be used.
- (c) Outlets
  - (i) All outlets such as switches, wall sockets etc. may be either flush mounting type, or of surface mounting type, as specified in the Additional Specifications.
  - (ii) All switches (except piano type switches), socket outlets and fan regulators shall be fixed on metal strips which shall be screwed / welded to the box. Piano type switches and accessories shall be fixed on the phenolic laminated sheet covers in flush pattern.
- (d) Painting after Erection

After installation, all accessible surfaces of conduit pipes, fittings, switch and regulator boxes etc. shall be painted in compliance with the clauses under Chapter 15 "Painting".

##### **4.4.2 Additional Requirements for Surface Conduit Work**

- (a) Painting before Erection

The outer surface of conduit including all bends, unions, tees, junction boxes etc. forming part of the conduit system, shall be adequately protected against rust when such system is exposed to weather, by being painted with 2 coats of red oxide paint applied before they are fixed.
- (b) Fixing Conduit on Surface
  - (i) Conduit pipes shall be fixed by saddles, secured to suitable approved plugs with screws in an

- approved manner at an interval of not more than one meter, but on either side of the couplers or bends or similar fittings, saddles shall be fixed at a distance of 30 cm from the center of such fittings.
- (ii) Where conduit pipes are to be laid along the trusses, steel joists etc. the same shall be secured by means of saddles or girder clips or clamps as required by the Engineer-in-charge.
  - (iii) In long distance straight run of conduit, inspection type couplers at reasonable intervals shall be provided, or running threads with couplers and jam nuts shall be provided.
- (c) Fixing Outlet Boxes
- Only portion of the switch box shall be sunk in the wall, the other portion being projected out for suitable entry of conduit pipes into the box.

#### **4.4.3 Additional Requirements for Recessed Conduit Work**

- (a) Making Chase
  - (i) The chase in the wall shall be neatly made and of ample dimensions to permit the conduit to be fixed in the manner desired.
  - (ii) In the case of buildings under construction, the conduits shall be buried in the wall before plastering, and shall be finished neatly after erection of conduit.
  - (iii) In case of exposed brick / rubble masonry work, special care shall be taken to fix the conduit and accessories in position along with the building work.
- (b) Fixing Conduits in Chase
  - (i) The conduit pipe shall be fixed by means of staples, J-hooks, or by means of saddles, not more than 60 cm apart or by any other approved means of fixing.
  - (ii) All threaded joints of conduit pipes shall be treated with some approved preservative compound to secure protection against rust.
- (c) Fixing Conduits in RCC Work
  - (i) The conduit pipes shall be laid in position and fixed to the steel reinforcement bars by steel binding wires before the concreting is done. The conduit pipes shall be fixed firmly to the steel reinforcement bars to avoid their dislocation during pouring of cement concrete and subsequent tamping of the same.
  - (ii) Fixing of standard bends or elbows shall be avoided as far as practicable, and all curves shall be maintained by bending the conduit pipe itself with a long radius, which will permit easy drawing in of conductors.
  - (iii) Location of inspection / junction boxes in RCC work should be identified by suitable means to avoid unnecessary chipping of the RCC slab subsequently to locate these boxes.
- (d) Fixing Inspection Boxes
  - (i) Suitable inspection boxes to the minimum requirement shall be provided to permit inspection and to facilitate replacement of wires, if necessary.
  - (ii) These shall be mounted flush with the wall or ceiling concrete. Minimum 65 mm depth junction boxes shall be used in roof slabs and the depth of the boxes in other places shall be as per IS 2667: 1988.
  - (iii) Suitable ventilating holes shall be provided in the inspection box covers.
- (e) Fixing Switch Boxes and Accessories
  - Switch boxes shall be mounted flush with the wall. All outlets such as switches, socket outlets etc. shall be flush mounting type, unless otherwise specified in the Additional Specifications.
- (f) Fish Wire
  - To facilitate subsequent drawing of wires in the conduit, GI fish wire of 1.6 mm/1.2 mm (16/18 SWG) shall be provided along with the laying of the recessed conduit.
- (g) Bunching of Cables
  - (i) Cables carrying Direct Current may, if desired, be bunched whatever their polarity, but cables carrying alternating current, if installed in metal conduit shall always be bunched so that the outgoing and return cables are drawn into the same conduit.
  - (ii) Where the distribution is for single phase loads only, conductors for these phases shall be drawn in one conduit.
  - (iii) In case of three phase loads, separate conduits shall be run from the distribution boards to the load

points, or outlets as the case may be.

#### 4.4.4 Earthing Requirements

- (a) The entire system of metallic conduit work, including the outlet boxes and other metallic accessories, shall be mechanically and electrically continuous by proper screwed joints, or by double check nuts at terminations. The conduit shall be continuous when passing through walls or floors.
- (b) A protective earthing conductor(s) shall be laid inside the conduit between the metallic switch boxes and distribution switch boards and terminated with proper earth lugs/ terminals. Only PVC insulated copper conductor cable of specified size green in colour shall be allowed.
- (c) The protective conductors shall be terminated properly using earth studs, earth terminal block etc. as the case may be.
- (d) Gas or water pipe shall not be used as protective conductor (earth medium).

**TABLE 4.1**  
**Maximum Number of PVC Insulated 650/1100 V grade Aluminium / Copper Conductor Cable**  
**conforming to IS 694:2018**  
 [Clause 4.2.1 (ii)]

Nominal cross sectional area of conductor in sq.mm	20 mm		25 mm		32 mm		38 mm		51 mm		64 mm	
	S	B	S	B	S	B	S	B	S	B	S	B
1	2	3	4	5	6	7	8	9	10	11	12	13
1.50	5	4	10	8	18	12	–	–	–	–	–	–
2.50	5	3	8	6	12	10	–	–	–	–	–	–
4	3	2	6	5	10	8	–	–	–	–	–	–
6	2	–	5	4	8	7	–	–	–	–	–	–
10	2	–	4	3	6	5	8	6	–	–	–	–
16	–	–	2	2	3	3	6	5	10	7	12	8
25	–	–	–	–	3	2	5	3	8	6	9	7
35	–	–	–	–	–	–	3	2	6	5	8	6
50	–	–	–	–	–	–	–	–	5	3	6	5
70	–	–	–	–	–	–	–	–	4	3	5	4

**Note:**

- (1) The above table shows the maximum capacity of conduits for a simultaneous drawing in of cables.
- (2) The columns headed 'S' apply to runs of conduits which have distance not exceeding 4.25 m between draw in boxes and which do not deflect from the straight by an angle of more than 15 degrees. The columns headed 'B' apply to runs of conduit, which deflect from the straight by an angle of more than 15 degrees.
- (3) Conduit sizes are the nominal external diameters.

**TABLE 4.2**  
**Girder Clips or Clamps**  
*[Clause 4.2.2 (iv) b]*

<b>Size of Conduit</b>	<b>Width</b>	<b>Thickness</b>
(i) 20 mm	19 mm	0.9 mm (20 SWG)
(ii) 25 mm	19 mm	0.9 mm (20 SWG)
(iii) 32 mm & above	25 mm	1.2 mm (18 SWG)

**4.5 Mandatory test :**

The Mandatory Test are applicable for original works ( original Works means all new constructions, site preparation, additions and alterations, special repairs to newly purchased or previously abandoned buildings or structures, including re-modelling or replacement).

The following below mentioned tests are the mandatory tests for rigid steel conduit:-

- (1) Bending Test
- (2) Compression Test
- (3) Resistance to Heat test
- (4) Resistance to Burning Test
- (5) Electrical Characteristics Test

The Testing including sampling shall be done as per BIS 9537: part 2:1981 (Reaffirmed 2017).

# CHAPTER 5

## NON-METALLIC CONDUIT WIRING SYSTEM

### 5.1 Scope

This chapter covers the detailed requirements for wiring work in non-metallic conduits. This chapter covers both surface and recessed types of wiring work.

### 5.2 Application

#### 5.2.1 Recessed conduit

Recessed conduit work is generally suitable for all applications. Surface conduit work may be adopted in places like workshops etc. and where recessed work may not be possible to be done. The type of work shall be as specified in individual works.

#### 5.2.2 Flexible non-metallic conduits

Flexible non-metallic conduits shall be used only at terminations, wherever specified.

#### 5.2.3 Special Precautions

- (a) If the pipes are liable to mechanical damages, they should be adequately protected.
- (b) Non-metallic conduit shall not be used for the following applications: -
  - (i) In concealed/inaccessible places of combustible construction where ambient temperature exceeds 60 degrees C.
  - (ii) In places where ambient temperature is less than 5 degrees C.
  - (iii) For suspension of fluorescent fittings and other fixtures.
  - (iv) In areas exposed to sunlight.

### 5.3 Materials

#### 5.3.1 Conduits

- (a) All non-metallic conduit pipes and accessories shall be of suitable material complying with IS 9537 (Part 3): 1983 (Reaffirmed 2017) and IS 3419:1988 (Reaffirmed 2017) for rigid conduits and IS 9537 (Part 5):2000 (Reaffirmed 2020) for flexible conduits. The interior of the conduits shall be free from obstructions. The rigid conduit pipes shall be ISI marked.
- (b) The conduits shall be circular in cross-section. The conduits shall be designated by their nominal outside diameter. The dimensional details of rigid non-metallic conduits are given in Table 5.1 below.
- (c) No non-metallic conduit less than 20 mm in diameter shall be used.
- (d) Wiring Capacity  
The maximum number of PVC insulated aluminium/copper conductor cables of 650/1100 V grade conforming to IS 694: 2018 that can be drawn in one conduit of various sizes is given in Table 4.1 under clause 4.3.1 (c). Conduit sizes shall be selected accordingly.

#### 5.3.2 Conduit Accessories

- (a) The conduit wiring system shall be complete in all respect including accessories.
- (b) Rigid conduit accessories shall be normally of grip type.
- (c) Flexible conduit accessories shall be of threaded type.
- (d) Bends, couplers etc. shall be solid type in recessed type of works, and may be solid or inspection type as required, in surface type of works.
- (e) Saddles for fixing conduits shall be heavy gauge non-metallic type with base.
- (f) The minimum width and the thickness of the ordinary clips or girder clips shall be as per Table 5.2.
- (g) For all sizes of conduit, the size of clamping rod shall be 4.5 mm (7 SWG) diameter.
- (h) All accessories of non-metallic conduit like junction box, bend etc. shall be ISI marked only (IS 3419:1988 (Reaffirmed 2017) for non metallic rigid conduits and BIS 3837:1976, Reaffirmed 2006, Accessories for Rigid non metallic Conduit).

### 5.3.3 Outlets

- (a) The switch box shall be made of either rigid PVC moulding, or mild steel, or cast iron on all sides except at the front. The regulator boxes shall however be made only of mild steel or cast iron.
- (b) PVC boxes shall comply with the requirements laid down in IS 14772: 2020. These boxes shall be free from burrs, fins and internal roughness.
- (c) The thickness of the walls and base of PVC boxes shall not be less than 2 mm. The clear depth of PVC boxes shall not be less than 60 mm.
- (d) The specifications for metallic boxes shall be as per requirements of clause 4.2.3.
- (e) 3 mm thick phenolic laminated sheet covers for all types of boxes shall be as per requirements of clause 3.14(c).
- (f) The modular switch boxes shall be of required number of modules, made of GI sheet steel/ PVC and compliant to relevant BIS.

## 5.4 Installation

### 5.4.1 Common Aspects for Both Recessed and Surface Conduit Works

- (a) The erection of conduits of each circuit shall be completed before the cables are drawn in.
- (b) Conduit Joints
  - (i) All joints shall be sealed/cemented with approved cement. Damaged conduit pipes/fittings shall not be used in the work. Cut ends of conduit pipes shall have neither sharp edges nor any burrs left to avoid damage to the insulation of conductors while pulling them through such pipes.
  - (ii) The Engineer-in-charge, with a view to ensuring that the above provision has been carried out, may require that the separate lengths of conduit etc. after they have been prepared shall be submitted for inspection before being fixed.

### (c) Bends in Conduit

- (i) All bends in the system may be formed either by bending the pipes by an approved method of heating, or by inserting suitable accessories such as bends, elbows or similar fittings, or by fixing non-metallic inspection boxes, whichever is most suitable. Where necessary, solid type fittings shall be used.
- (ii) Radius of bends in conduit pipes shall not be less than 7.5 cm. No length of conduit shall have more than the equivalent of four quarter bends from outlet to outlet.
- (iii) Care shall be taken while bending the pipes to ensure that the conduit pipe is not injured, and that the internal diameter is not effectively reduced.

### (d) Outlets

All switches, plugs, fan regulators etc. shall be fitted in flush pattern. The fan regulators can be mounted on the switch box covers, if so stipulated in the tender specifications, or if so directed by the Engineer-in-charge.

### (e) Painting

After installation, all accessible surfaces of metallic accessories shall be painted in compliance with clauses under Chapter 15 "Painting".

### 5.4.2 Additional Requirements for Surface Conduit Work

- (a) Conduit pipes shall be fixed by heavy gauge non-metallic saddles with base, secured to suitable approved plugs with screws in an approved manner, at an interval of not more than 60 cm, but on either side of couplers or bends or similar fittings, saddles shall be fixed at a closer distance from the centre of such fittings. Slotted PVC saddles may also be used where the PVC pipe can be pushed in through the slots.
- (b) Where the conduit pipes are to be laid along the trusses, steel joists etc. the same shall be secured by means of saddles or girder clips as required by the Engineer-in-charge. Where it is not possible to use these for fixing, suitable clamps with bolts and nuts shall be used.
- (c) If the conduit pipes are liable to mechanical damage, they shall be adequately protected.

### 5.4.3 Additional Requirements for Recessed Conduit Work

- (a) Making Chase  
Requirements under clause 4.3.3 (i) shall be complied with.
- (b) Fixing Conduits in Chase
  - (i) The conduit pipe shall be fixed by means of staples, or by means of non-metallic saddles, placed at not more than 60 cm apart, or shall be fixed by any other approved means of fixing.
  - (ii) At either side of the bends, saddles/staples shall be fixed at a distance of 15 cm from the centre of the bends.
- (c) Erection in RCC Work  
Requirements under clause 4.3.3 (iii) shall be complied with.
- (d) Fixing Inspection Boxes  
Requirements under clause 4.3.3 (iv) shall be complied with.
- (e) Fixing Switch Boxes and Accessories  
Requirements under clause 4.3.3 (v) shall be complied with.
- (f) Fish Wire  
Requirements under clause 4.3.3 (vi) shall be complied with.
- (g) Bunching of Cables  
For ease of maintenance, cables carrying direct current or alternating current shall always be bunched so that the outgoing and return cables are drawn in the same conduits.

### 5.4.4 Earthing Requirements

- (a) A protective (earth) conductor shall be drawn inside the conduit in all distribution circuits to provide for earthing of non-current carrying metallic parts of the installation. These shall be terminated on the earth terminal in the switch boxes, and/or earth terminal blocks at the DBs.  
Gas or water pipe shall not be used as protective conductors (earth medium).

**TABLE 5.1**  
**Dimensional Details of Rigid Non-metallic Conduits**  
[Clause 5.2.1(ii)]

*(All dimensions in mm)*

S. No.	Nominal Outside Diameter (in mm)	Maximum Outside Diameter (in mm)	Minimum Inside Diameter (in mm)	Maximum Permissible Eccentricity (in mm)	Minimum Permissible Ovality (in mm)
1.	20	20 + 0.3	17.2	0.2	0.5
2.	25	25 + 0.3	21.6	0.2	0.5
3.	32	32 + 0.3	28.2	0.2	0.5
4.	40	40 + 0.3	35.8	0.2	0.5
5.	50	50 + 0.3	45.0	0.4	0.6

**TABLE 5.2**  
**Ordinary Clips or Girder Clips**  
[Clause 5.2.2(vi)]

Size of Conduit	Width	Thickness
(1) 20 mm & 25 mm	19 mm	20 SWG (0.9144 mm)
(2) 32 mm & above		18 WG (1.219 mm)

## **5.5 Mandatory test :**

This Mandatory Test is applicable for original works only ( original Works means all new constructions, site preparation, additions and alterations, special repairs to newly purchased or previously abandoned buildings or structures, including re-modelling or replacement).

The Acceptance Test as mentioned in IS 9537- Part 3: 1983 (Reaffirmed 2017) shall constitute the mandatory test for non-metallic rigid conduit :

- (a) Dimension Test
- (b) Bending Test
- (c) Compression Test
- (d) Resistance to Heat test
- (e) Resistance to Burning Test
- (f) Electrical Characteristics Test

# CHAPTER 6

## TRUNKING CABLE MANAGEMENT SYSTEM

### 6.1 Scope

This chapter covers the requirements of mini trunking (casing wiring) and adaptable metallic or PVC trunking (“otherwise also called wire ways”).

### 6.2 Application

Adaptable trunking shall be used for power cables and data cables to run parallel in two different compartments with partition.

6.2.1 Mini Trunking is suitable for surface wiring work indoors where necessitated, either due to aesthetics or technical requirements, such as case of extension of existing wiring, avoidance of recessed wiring in RCC columns etc. PVC insulated cables and/ or other approved insulated cables conforming to IS 694: 2018 shall be used in this type of work.

6.2.2 Wherever data cables are used for information outlets, adaptable trunking shall be used.

6.2.3

- (i) This system using PVC trunking shall be adopted in residential buildings, or office building where there is a need of tidy wiring system.
- (ii) PVC trunking for distribution of Voice Data and Power should be used for cable management and should accept RJ45 Data socket and Power socket or other wiring accessory like switches, indicators etc.
- (iii) Where the trunking has to be necessarily adopted in situations under (i) above, PVC trunking shall be used.
- (iv) Preferred size of the mini trunking should be 25 x 16 mm, 32 x 16 mm, 40 x 25 mm, 40 x 40 mm and for adaptable trunking it should be 100 x 34 mm or 100 x 50 mm or 160 x 50 mm or 200 x 50mm for making up to four isolated compartments.
- (v) Trunking should be equipped with rail on its surface on which clip-on partition can be clipped which should accept frames/plates for wiring devices up to 6/8 modules.
- (vi) Trunking should have insulation rating of 5 mega Ohm. Trunking should have the following fire resistance characteristics:
  - Operating temperature between – 40 Deg to 60 Deg. C
  - Glow wire test 960 Deg. C
  - Oxygen index – 50 ± 5
  - UL94 – VO

### 6.3 Material

#### 6.3.1 Type of Material

The mini trunking and adaptable trunking shall be of the same material, viz. either PVC or anodized aluminium in extruded sections.

#### 6.3.2 Shape

The mini trunking shall have a square or rectangular body. The trunking cover shall be “CLIP-ON” type with double grooving in the case of PVC wire-ways, and CLIP-ON type for the metallic wire ways. All surfaces shall have smooth finish inside and outside. The top of the side walls of the body shall be suitable for the above types of fixing arrangement of trunking. PVC trunking or Aluminium trunking should have uniform thickness throughout its length and shall be of factory finish.

#### 6.3.3 Quality

PVC trunking shall be of good quality PVC, free from defects like deformation, unevenness, blisters, cavities etc.

#### 6.3.4 Dimensions

- (a) The sizes of mini trunking for the various sizes of cables and the maximum number of 650/1100 V grade PVC insulated aluminium / copper conductor cables that can be carried in one trunking are given size wise in Table 6.1 below.
- (b) The thickness of the mini trunking & adaptable trunking shall be 1 mm minimum.

- (c) When mini trunking cover is clipped onto the trunking body, cover should completely overlap on the base (casing).

#### 6.3.5 Outlet Boxes

The outlet boxes such as switch boxes, regulator boxes and their phenolic laminated sheet covers shall be as per requirements.

### 6.4 Installation

#### 6.4.1 Attachment to Wall and Ceiling

- (a) The mini trunking and adaptable trunking shall be fixed by means of suitable screws to approved type of asbestos or fibre fixing plugs, at intervals not exceeding 60 cm for all sizes for mini trunking. In case of Adaptable trunking, the screwing distance shall be such that the weight of the trunking & cable holds firmly on the wall or ceiling. On either side of the joints, the distance of the fixing arrangement shall not exceed 15 cm from the joint.
- (b) All trunking body shall be fixed directly on wall or ceiling as above.
- (c) Trunking shall be used only on dry walls and ceiling, avoiding outside walls as far as possible and shall not be buried in walls not fixed in proximity to gas, steam or water pipes or immediately below the heater.
- (d) Adaptable trunking shall be with pill off cover for protection against dust. Pill off cover shall be removed only on completion of painting of walls.

#### 6.4.2 Passing through Floors or Walls

When conductors pass through floors, the same shall be carried in an approved PVC conduit, or heavy gauge steel conduit properly bushed at both ends. The conduit shall be carried 20 cm above floor level and 2.5 cm below ceiling level and neatly terminated into the casing. Steel conduit pipes wherever accessible shall be securely earthed.

#### 6.4.3 Joints in Casing and Capping

- (a) The wire ways in straight runs should be in single piece as far as possible so as to avoid joints. Trunking shall be of 2 m or 3 m standard length for the ease of installation.
- (b) All joints shall be scarfed or cut diagonally in longitudinal section, and shall be smoothed down by filing to make the joints a very close fit as far as possible and without burrs. They shall be screwed at joints with two or more screws as would be necessary.
- (c) Joints arising out of bends or diversion shall be done using standard accessories like Internal angle, External angle, Flat angle (elbows), Flat junction (T) and end caps. For the separation of data and power cables there shall be partition in both trunking and accessories. Internal and external angle shall have variable angle for the alignment at the wall corners. In no case the radius of curvature of the cables inside a bend shall be less than 6 times their overall diameter.

#### 6.4.4 Trunking should be of white colour in case of PVC trunking and of white or grey colour in case of Aluminium trunking.

Mini Trunking attached to ceiling shall be carried completely across the ceiling/ wall whenever required by the Engineer-in-charge, instead of being stopped at an outlet location and in all such cases, dummy mini trunking must be provided.

#### 6.4.5 Attachment of Capping

- (a) Wherever required by the Engineer-in-charge, capping shall not be fixed until the work has been inspected with the wires in position and approved. The inspection will be done from time to time as the work progresses.
- (b) Cover shall be attached to body after all the insulated wires are laid inside.
- (c) No screws or nails shall be used for fixing PVC cover to the body.
- (d) Aluminium cover shall be fixed by using cadmium plated flat head / round head screws with an axial spacing not exceeding 30 cm.

#### 6.4.6 Installation of Cables

- (a) For ease of maintenance, cables carrying direct current or alternating current shall always be bunched so that the outgoing and return cables are drawn in the same trunking.
- (b) Mini trunking shall be of such a design that it holds the wires inside the trunking body (casing) at suitable intervals, so that at the time of opening of the trunking cover (capping), the wires may remain in position in the trunking body (casing) and do not fall out.

#### 6.4.7 Earth Continuity

- (a) A protective earth conductor shall be drawn inside for earthing of all metallic boxes of the installations as well as for connections to the earth pin of the socket outlets.
- (b) In the case of metallic trunking there shall be a metallic link between adjacent trunking covers with screw connections, and also connections from the end casing to the earth terminal of metallic boxes / outlets / switch boards as per the case may be, for the complete body earthing of the system.

**TABLE 6.1**  
**Maximum Number of PVC Insulated 650/1100 Volt Grade Aluminium/Copper**  
**Conductor Cable conforming to IS 694: 2018**  
[Clause 6.3.4(a)]

Nominal Cross Section Area	10/15 mm x 10mm	20/15 mm x 10mm	25/15 mm x 16mm	32 mm x 16 mm	40 mm x 25 mm	40 mm x 40 mm
1.5	3	5	6	8	12	18
2.5	2	4	5	6	9	15
4	2	3	4	5	8	12
6		2	3	4	6	9
10		1	2	3	5	8
16			1	2	4	6
25				1	3	5
35					2	4
50					1	3
70					1	2

**Note :** Dimensions shown above are outer dimensions of mini trunking.

## CHAPTER 7

# Power switchgear and control gear assemblies (PSC-Assemblies) (LT Panels), D.B., Rising Mains, Bus Trunking and Overhead Bus bar System

### 7.1 Scope

This covers supply/ erection/ testing and commissioning of the equipment suitable for 415 Volt, 3 Phase, 50 HZ 4 wire system.

### 7.2 Requirements

- (a) For each equipment, required IP rating and short circuit rating capacity will be specified. Governing BIS/ IEC also will be specified.
- (b) All the equipment will be factory fabricated in an approved factory having modern fabrication and testing process. It shall have seven tank pre-treatment process comprising of degreasing, rinsing, de-rusting, rinsing, phosphatising, rinsing and passivation followed by powder coat painting having a paint thickness of 60 microns or as specified. The powder paint will be subjected to oven-heated process. All panels will be provided with suitable gasket to make it dust/ vermin proof.

#### 7.2.1 Power switchgear and control gear assemblies (PSC-ASSEMBLIES)( LT Panels)

It is combination of one or more low-voltage switching devices together with associated control, measuring, signalling, protective, regulating equipment, with all the internal electrical and mechanical interconnections and structural parts. This clause of specification is applicable to PSC-ASSEMBLIES for which the rated voltage does not exceed 1 000 V in case of a.c.

- (a) This section covers the detail requirements for Design, Manufacturing, Testing and Verification at works of the L.T. Panel made out of CRCA/GI Zinc Coated sheet steel indoor type, floor mounted, free standing, totally enclosed, extensible type, air insulated type for use on 415 Volts, 3 phase with neutral, 50 cycles/sec system. The LT panel construction performance, testing and verification shall conform to (a) IS/IEC 61439-1: 2011 (Low-Voltage Switchgear and Control gear Assemblies - Part 1 General Rules), b) IS/IEC 61439-2: 2011 (Low-voltage switchgear and control gear assemblies – Part 2: Power switchgear and control gear assemblies.

The equipment shall be designed to conform to the requirements of:

Individual equipment housed in the Main L.T. Panels shall conform to the following IS Specification.

- |  |   |
|--|---|
| (i) Air circuit breakers/ moulded case circuit breaker | IS: 60947 (Part-II) & IEC 60947(2)        |
| (ii) Fuse switch and switch fuse units                 | IS: 13947 (Part-3) & IEC 947 (3).         |
| (iii) HRC fuse links                                   | IS: 13703                                 |
| (iv) Current Transformers                              | IS :2705                                  |
| (v) Voltage Transformers                               | IS :3156                                  |
| (vi) Indicating Instruments                            | IS: 1248                                  |
| (vii) Integrating Instruments                          | IS : 722                                  |
| (viii) Control Switches & Push Buttons                 | IS : 6875                                 |
| (ix) Auxiliary Contactors                              | IS: 13947 (Part-4/Sec.-I) & IEC 947 (4/1) |
| (x) Relays   | IS: 3231                                  |

- (b) The panel shall be compartmentalized type having space and arrangement for incoming cable/ bus ducting, incoming switchgear/ switchgears, bus coupler, insulated and properly supported

compartmentalized bus bars, outgoing compartmentalized switchgear, bus bar supports, joint shrouds, cable alleys of suitable size for cabling routing, support and terminations, inter-connection between bus bars and switchgear with auxiliary bus bars/ insulated conductors/ strips etc. Also, the panel will be provided with necessary instrumentation like CTs, PTs, Ammeters, Voltmeters, phase indicating lamps, other required instruments, wiring, fuses etc.

- (c) It shall be fabricated out of CRCA sheet not less than 2.0 mm thick for load bearing members/ GI 275GSM Zinc coated metal. and 1.6 mm for doors of LT panels. General constructions shall employ the principle of compartmentalization and segregation of each circuit. Unless otherwise approved, incomer and bus section panels shall be separate and independent and shall not be mixed with sections required for feeders. Operating handle of the highest unit shall be at a height not more than 1.7 mt. Overall height of the board shall not exceed 2.3 metre.
- (d) **Arrangement for Incoming/Outgoing Cable Termination**  
Cable entries shall be provided either from the rear or from the front through cable alleys of suitable size. Removable gland plate to be provided for each cable entry. Cable support arrangement to be provided inside cable alley so that cables are neatly arranged and fixed. From each outgoing switch, insulated strip/ conductor of suitable size to be provided up to suitable terminal block, which will receive incoming/ outgoing cable termination. It is desirable that cables are not terminated directly to switchgear, but terminated through proper terminal blocks.
- (e) **Specification of Cable Terminal Block**  
Terminal block of reputed make shall be used. The housing material shall be polyamide having unbreakable and fire-retardant characteristic. All the metal parts shall be made up of copper alloy including the screws. Mounting shall be 'Din' or 'G-rail' type. Screws shall be self-captive type. No protection cover is required, and the block should be touch proof.
- (f) **Bus bars/ Supports/ Clearances**  
The bus bar system may comprise of a system of main/ auxiliary bus bars run in bus bar alleys. For bus bar material, ratings, current density, insulation, supports, bus bar clearances and joints see para 7.2 (iii).
- (g) **Earthing**  
Protective earthing conductor shall be sized according to Table F-5 of Chapter- 17- Appendix F and shall conform to IS/IEC 61439-1 : 2011 and IS/IEC 61439-2 : 2011. Earth busbars shall be fixed in the panel connected to incoming protective earth conductors. 2 no's of busbar and connections are recommended.  
(Layout of Electrical Panel is explained in Chapter -19 Fig. 7)
- (h) **Commissioning**  
After erection, the LT panel will be commissioned after:
- Tightening of all nuts and bolts.
  - Closing any left-out holes to ensure the entire panel is insect proof.
  - Megger testing.
  - Earth testing.
- (i) The enclosures shall be designed to take care of normal stress as well as abnormal electro-mechanical stress due to short circuit conditions. All covers and doors provided shall offer adequate safety to operating persons and provide ingress protection of IP 42 unless otherwise stated. Ventilating openings and vent outlets, if provided, shall be arranged such that same ingress protection of IP 42 is retained. Suitable pressure relief devices shall be provided to minimize danger to operator during internal fault conditions. The design should have undergone Internal Arc tests for different types of feeders.
- (j) For operator safety IP2 X (touch proof) protection to be available even after opening the feeder

compartment door. The compartmentalization to be achieved by using metal separators, use of PVC sheet / Hylem sheets shall not be allowed.

- (k) Switchboard shall have finger touch proof design with rear Terminals for MCCB feeders. Rear stud terminals shall be used directly on MCCB to avoid any direct touch in the front.

### 7.2.2 Switchboard Configuration

- (a) The Switchboard shall be configured with Air Circuit Breakers, MCCB's, MPCB, MCB's and other equipment as called for in the schedule of quantities.
- (b) The MCCBs shall be arranged in multi-tier formation. The incoming Air Circuit Breakers shall be arranged in Single tier formation only but Double tier formation to facilitate operation and maintenance may be used for outgoing air circuit breakers only.
- (c) The Switchboards shall be of adequate size with a provision of spare space to accommodate possible future additional switch gear.

### 7.2.3 Constructional Features

- (a) The Switchboards shall be metal clad totally enclosed, floor mounted free standing type of modular bolted type extensible design suitable for indoor mounting. Switchboard shall have a double front door arrangement to avoid unauthorized access. Suitable locking arrangement has to be considered.
- (b) Switchboards construction shall employ the principle of compactization and segregation for each circuit.
- (c) Incomer and bus section panels or sections shall be separate and independent and shall not be wired with sections required for feeder. The incomer panel shall be suitable for receiving bus trunking or MV cable of size specified.
- (d) Switchboards shall be made up of requisite vertical sections, which when coupled together, shall form continuous dead front switchboards.
- (e) Switchboard shall be readily extensible on both sides by addition of vertical sections after removal of the end covers.
- (f) The switchboards shall be designed for use in high ambient temperature and humid tropical conditions as specified. Ease of inspections, cleaning and repairs while maintaining continuity of operation shall be provided in the design.
- (g) Metal based Polyurethane gaskets between all adjacent units and beneath all covers shall be provided to render the joints dust and vermin proof to provide required degree of protection as stipulated in schedule of quantities. The unused openings within the switchboards shall be closed using suitable grommets.
- (h) Special care to be taken to ensure effective earthing of the frame and doors of the switchboards.
- (i) Each vertical section shall be provided with a rear or side cable chamber housing the cable end connections and power/control cable terminations. There should be generous availability of space for ease of installation and maintenance with adequate safety for working in one vertical section without coming into contact with any live parts. The design of the switchboard shall allow standard extension chambers if required to accommodate cables.
- (j) Switchboard panels and cubicles shall be fabricated with CRCA/GI Sheet Steel of thickness not less than 2.0 mm and shall be folded and braced as necessary to provide a rigid support for all components. The doors and covers shall be fabricated from CRCA sheet steel of thickness as per manufacturer standard. Joints of any kind in sheet metal shall be bolted construction.
- (k) All panels and covers shall be properly fitted. The holes in the panel shall be correctly positioned.
- (l) Switchboard shall be provided with "Danger Notice Plate" conforming to relevant Indian Standards.
- (m) Panel shall be tested for Seismic withstand of Zone-IV as per IEEE/IEC/BIS.
- (n) All panels shall have facility for providing tubing for gas flooding system. The gas flooding shall be provided by the Panel Manufacturer / third party, as specified in the tender, just before the commissioning of the Panel. These Gas flooding system shall also be connected to the FAS through a monitor module

#### 7.2.4 **Switchboard Dimensional Limitations**

- (a) The overall height of the switchboard shall be limited to 2450 mm or less as per manufacturer's standards for all the Bus bar ratings and type of switchboards.
- (b) The height of the operating handle, push buttons etc shall be restricted between 300 mm and 1800 mm from finished floor level.
- (c) Other dimensional limits if any are specified separately.

#### 7.2.5 **Switchboard Compartmentalization**

- (a) For compartmentalized switchboards, separate totally enclosed compartments shall be provided for horizontal busbars, vertical busbars, ACBs, MCCBs, and cable alleys.
- (b) All feeders having ACB & MCCB shall have rear or front terminal cable connection as specified in the tender / as per requirements of site.
- (c) The main board shall be with Form 4b Construction. Form 4b Construction has provisions for Separation of busbars from all functional units, Separation of all functional units from one another, Separation of terminals for external conductors associated with a functional unit from the terminals of any other functional unit and the bus bars, Separation of the external conductors from the busbars, Separation of the external conductors associated with a functional unit from other functional units and their terminals, External conductors need not be separated from each other and Terminals not in same compartment as associated functional unit as per IEC 61439-2.
- (d) Earthed metal or insulated shutters shall be provided between draw out and fixed portion of the switchgear such that no live parts are accessible with equipment drawn out. Degree of protection within compartments shall be at least IP 2X.
- (e) Sheet steel hinged lockable doors for each separate compartment shall be provided and duly interlocked with the breaker in "ON" and "OFF" position.
- (f) For all Circuit Breakers separate and adequate compartments shall be provided for accommodating instruments, indicating lamps, control contactors and control MCB etc. These shall be accessible for testing and maintenance without any danger of accidental contact with live parts of the circuit breaker, busbars and connections.
- (g) Each switchgear cubicles shall be fitted with label in front and back identifying the circuit, switchgear type, rating and duty. All operating device shall be located in front of switchgear only.
- (h) A suitable wire way with cover shall be provided to take interconnecting control wiring between vertical sections.
- (i) Cable compartments shall be of adequate size for easy termination of all incoming and outgoing cables entering from bottom or top. The construction shall include necessary and adequate and proper support shall be provided in cable compartments to support and clamping the cable in the cable alley / cable chamber.

#### 7.2.6 **Switchboard Bus Bars**

- (a) Busbars shall be made of high conductivity, 99.9% purity, high strength Aluminium of ETP grade Busbars shall be of rectangular cross sections, suitable for 1.25 times full load current for phase and Neutral bus bar or as stipulated in schedule of quantities. Busbar shall be suitable to withstand the stresses of fault level as specified in schedule of quantities.
- (b) The bus bar system may comprise of a system of main horizontal bus bars and auxiliary vertical bus bars run in bus bar alley on either side in which the circuit could be arranged with front access for cable entrances.
- (c) The bus bars shall be supported on non-breakable, non-hygroscopic epoxy resin or glass fiber reinforced polymer insulated supports able to withstand operating temperature of 110<sup>0</sup> C at regular intervals, to withstand the forces arising from a fault level as stipulated in schedule of quantities. The material and the spacing of the Busbar supports should be same as per the type tested assembly & supplied by OEM with valid test reports.
- (d) Auxiliary buses for control power supply, space heater power supply or any other specified service shall be provided. These buses shall be insulated, adequately supported and sized to suit specific requirement. The material for auxiliary supply bus will be insulated electrolytic copper.

- (e) **Clearances**  
The minimum clearances to be maintained for enclosed indoor air insulated bus bars for medium voltage applications shall be as per IEC guidelines

#### 7.2.7 **Switchboard Interconnection**

- (a) All connection and tap offs shall be through adequately sized connectors appropriate for fault level at location. This shall include tap off to feeders and instrument/control transformers.
- (b) For unit ratings up to 100 amps, PVC insulated 105 deg withstand, copper conductor wires of adequate size to carry full load current shall be used. The terminations of such interconnections shall be crimped. Solid connections shall be used for all rating of above 100 amps.
- (c) All connections, tapings, clamping, shall be made in an approved manner to ensure minimum contact resistance. All connections shall be firmly bolted and clamp with even tension. Before assembly joint surfaces shall be filed or finished to remove burrs, dents and oxides and silvered to maintain good continuity at all joints. All screws, bolts, washers shall be zinc plated. Suitable grade nuts and bolts shall be used for busbar connections.

#### 7.2.8 **Draw out Features**

Air Circuit Breakers shall be provided in fully draw out cubicles, unless otherwise stated. These cubicles shall be such that draw out is possible without disconnection of the wires and cables. The power and control circuits shall have self-aligning and self-isolating contacts. Mechanical latches shall be integrated in ACB at service, test and isolated position to ensure that Breaker is firmly latched in respective position. It shall not be possible to move the breaker from the position unless latch is manually operated.

#### 7.2.9 **Instrument Accommodation**

- (a) All voltmeter and ammeter and other instruments shall be flushed mounted type of size 96sq.mm conforming to class 1.0 or as specified to IS 1248 for accuracy.
- (b) Instruments and indicating lamps shall not be mounted on the Circuit Breaker Compartment door for which a separate and adequate compartment shall be provided and the instrumentation shall be accessible for testing and maintenance without danger of accidental contact with live parts of the Switchboard.
- (c) For MCCBs, instruments and indicating lamps can be provided on the compartment doors.
- (d) The current transformers for metering and for protection shall be mounted on the solid copper/aluminium busbars with proper supports.

#### 7.2.10 **Wiring**

All wiring for relays and meters shall be with PVC insulated copper conductor FRLS wires. The wiring shall be coded and labeled with approved ferrules for identification. The minimum size of copper conductor control wires shall be 1.5 sq. mm. Runs of wires shall be neatly bunched and suitably supported and clamped. Means shall be provided for easy identification of wires. Identification ferrules shall use at both end of wires. All control wires meant for external connections are to be brought out on a terminal board. The cables and control wires shall be suitable for withstanding 105 deg C.

#### 7.2.11 **Space Heaters**

Anti- condensation heaters shall be fitted in each cubicle together with an ON/OFF isolating switch suitable for electrical operation at 230 volts A.C 50 Hz single phase of sufficient capacity to raise the internal ambient temperature by 50 C. The electrical apparatus so protected shall be designed so that the maximum permitted rise in temperature is not exceeded if the heaters are energized while the switchboard is in operation. As a general rule, the heaters shall be placed at the bottom of the cubicle.

### 7.2.12 Earthing

Continuous earth bus sized for prospective fault current to be provided with arrangement for connecting to station earth at two points. Hinged doors / frames to be connected to earth through adequately sized flexible braids.

### 7.2.13 Sheet Steel Treatment and Painting

Sheet steel used in the fabrication of switchboards shall undergo a rigorous cleaning and surface treatment seven tank process comprising of alkaline degreasing, descaling in dilute sulphuric acid and a recognized phosphating process after which a coat of primer paint compactively with the final paint shall be applied over the treated surface. Final paint coat of oven baked powder coating, of minimum 50 micron thickness, of sheet approved by Engineer-in-Charge shall then be provided.

### 7.2.14 Name Plates and Labels

Suitable engraved white on black name plates and identification labels of metal for all Switchboards and Circuits shall be provided. These shall indicate the feeder number and feeder designation.

### 7.2.15 Design Verification :

#### 7.2.15.1 Routine verification:

Routine verification is intended to detect faults in materials and workmanship and to ascertain proper functioning of the manufactured ASSEMBLY. It is made on each ASSEMBLY. Routine verification shall be as per IEC 61439 I & II. Copies of the routine test certificates shall be submitted by successful tenderers.

The routine verification test are as given below:

- (i) Construction
  - (a) degree of protection of enclosures;
  - (b) clearances and creepage distances;
  - (c) protection against electric shock and integrity of protective circuits;
  - (d) incorporation of built-in components;
  - (e) internal electrical circuits and connections;
  - (f) terminals for external conductors;
  - (g) mechanical operation.
- (ii) Performance
  - (a) dielectric properties;
  - (b) Wiring, operational performance and function.

#### 7.2.15.2 Design verification :

Design verification and type testing shall be as per IEC 61439-1 and IEC 61439-2. The major parameters/test for design verification are mentioned in Appendix –I-2

#### 7.2.15.3 General Tests:

- (a) A general visual check shall be carried out. This shall cover measurement of over all dimension, location, number and type of devices, terminal boxes, location and connection of terminals etc.
- (b) Checking of bill of materials as per approved drawing.
- (c) Checking of operation of various feeders as per approved schematic drawings.
- (d) Operation check shall be carried out for every control function as per schematic drawings by manually simulating fault conditions and operation of control switches/relays etc.
- (e) Checking of interchange-ability of identical feeders.

### 7.2.16 Power and control switchgear assembly/ LT Panels shall be ready to communicate for electrical distribution control system with cloud computing platform as per following :

LT Panels having Incomer of 630A or higher shall be ready to communicate with a cloud computing platform architecture able to satisfy supervision of electrical system and performance, analysis of

relevant data and optimization of installation, control and implementation of energy management strategy.

The system must be scalable, shall be able to collect data from main electrical LV components installed in main and sub-distribution switchboards, and shall establish cloud connection.

Web clients can access to dashboard and data on web, where is possible to configure the system and customize reports and alarms. These panels shall be hooked up with the BMS, if provided.

All native device types have been factory-tested and proven to perform. The Software Platform shall be certified as part of an Energy Data Management System according to the sections of the following ISO standards:

- (a) ISO 50001 : Energy review, Energy baseline, Energy performance indicators, and analysis Input to management review
- (b) ISO 50002: Data collection, Measurement plan Analysis, Energy audit reporting
- (c) ISO 50006: Obtain relevant energy performance information from the energy review Identify energy performance indicators

The Software Platform shall be certified to comply with cybersecurity standard IEC62443 at the component level: IEC62443-4-1 and IEC62443-4-2 (SLI).

The Software Platform shall be designed to streamline the process of checking and maintaining EN50160, IEC61000-2-4 and IEEE 519 Power Quality compliance. The Software Platform shall natively support the vendor's continuous electrical thermal monitoring system with the ability to detect abnormal bus bar or cable temperatures due to loose or faulty connections and to prevent equipment damage and fire. 7. The Software Platform shall be designed to integrate and embed within the vendor's Building Management System (BMS) software platform to provide Energy and Power Management applications within the context of the BMS environment.

#### 7.2.17 **Electrical Standards**

Components shall be compliant to latest versions of following standards and regulations:

- IEC 60947-1 “Low-voltage switchgear and control gear – Part 1: General rules”
- IEC 60947-2 “Low-voltage switchgear and control gear – Part 2: Circuit-breakers”
- IEC61131-3 “Programmable controllers – Part 3: Programming languages”
- IEC 60870-5-104 “Telecontrol equipment and systems – Part 5-104: Transmission protocols – Network access for IEC 60870-5-101 using standard transport profiles” EC directives:
- “Low voltage Equipment” No. 2006/95/EC
- “Electromagnetic compatibility Directive” (EMC) No.2004/108/EC

#### 7.2.18 **Environmental characteristics**

Temperature:

- Operating temperature: -25 °C ...+70 °C
- Storage temperature: -40 °C... +70 °C

#### 7.2.19 **Environmental parameters:**

device shall comply with IEC60721-3-6 (class 6C3) and IEC60721-3-2 (class 3C2).

Pollution degree: device shall be used in environments type PD3

Vibrations: device shall comply with IEC60068-2-6 (1 mm displacement 1-13Hz, 13-100 Hz with acceleration = 0.7 g).

#### 7.2.20 **Functional characteristics**

Supervision system shall be able to collect data from the field and, through Ethernet bus, store information in one system, accessible via Cloud. Data and parameters measured depend on electrical devices connected, in addition to monitoring of electrical magnitudes; system shall provide status and maintenance indicators, alarms and alerts. Main device of supervision system architecture is a

communication module with an integrated software that behave as concentrator and gateway, allowing management of parts of electrical system located in different areas directly from web application.

#### 7.2.21 Scalability

It shall be possible to design different architecture sizes, with adoption of one single communication module or it shall be possible to integrate more communication modules to supervise one electrical installation, according to number of devices interconnected and functionalities required. System shall have high degree of flexibility enabling the integration on electrical systems already installed with limited impact on existing architecture. System scalability shall ensure integration of new devices without requiring re-programming or re-configuration of the connected system.

#### 7.2.22 Electrical Devices

It shall be possible to connect supervision system to electrical devices provided with communication protocols supported. It shall be possible to interconnect to cloud supervision system devices of type specified below:

- Air circuit breakers
- Moulded Case circuit breaker
- Metering devices
- Metering and monitoring device system for miniature circuit breaker
- Fuse gear
- Digital Meters / sensors
- Arc flash protection system

#### 7.2.23 Communication

Protection and metering devices shall be provided with standard communication protocols Modbus TCP/IP. Main communication module shall work as interface between electrical devices and cloud and shall be provided with Ethernet gate. System shall provide automatic monitoring of communication, and alerts shall be notified in case of communication problems.

#### 7.2.24 Data storage and notifications

Supervision system shall have a data logging interval of 30 seconds to ensure a fast reaction in case of warning or alerts and a continuous measure for reliable efficiency analysis. Supervision system shall be designed to monitor following data, without storage limitation Capability Consumption measures:

- Real time phase currents
- Voltages
- Active Power
- Reactive Power
- Apparent Power
- Active Energy
- Reactive Energy
- Apparent Energy
- Power Factor
- Peak active Power

##### **Quality data**

- THD
- Total reactive Power
- Voltage Unbalance
- Voltage Spike

- Voltage micro-interruption
- Voltage short Sage
- Voltage middle Sag
- Voltage long Sag
- Voltage short Swell
- Voltage Long Swell

#### **Maintenance data**

- Contact wear
- Number of trips
- Total operations
- Manual operations

It shall be possible to monitor status of devices and alarms. It shall be possible for web user to set up to 23 different alerts, identifying alerts for specific devices or on all devices, in order to schedule maintenance and to check health of installation.

#### **Alerts shall include:**

- Phase and neutral currents
- Phase to phase and phase to neutral voltages
- Total active power
- Total reactive power
- Total apparent power
- Power factor
- Number of operations
- Contacts wear
- Trip coil disconnected
- Overtemperature
- Motor operator overtemperature
- Circuit breakers trip
- Any trip
- Status Open/ close

It shall be possible to set alarms and define type of notification through SMS or e-mail for each user.

#### **7.2.25 Analytics and reports**

Supervision system shall be provided with web app with preconfigured widget to allow immediate overlook of plant consumption and analytics based on collection of data on selectable period of one day, one week, one month, one semester, one year or on custom period. Widget should be designed to display single or multi-site information and shall include both power utility consumption and power generated on site.

Web app shall allow the creation and customization of “digital” representation of asset, allowing creation of synoptic representation of switchboard, importation of single line diagram or switchboards’ front view. It shall be possible to activate the graphics by connection with markers or tags, to easily access to device data. Export of data and trends in excel shall be possible both on-demand and via automatic report scheduling function. It shall be possible to generate reports for all information managed or generate

customize reports selecting specific measures and devices. Benchmark on multi-site level shall also be possible to compare plants and systems and identify best practices.

#### **7.2.26 Commissioning and maintenance**

System shall allow final user or panel builder to execute the commissioning with the simple use of free software provided by manufacturer. Automatic recognition of devices shall be ensured so that there are no needs of programming and free software shall include wizard for commissioning directly from web. Free software provided by manufacturer shall allow execution of system

implementation without requiring system integrator.

#### 7.2.27 **Interface**

System shall be supplied with pre-set graphic pages with dashboard for immediate evaluation and management of power consumption. It shall be possible to display dashboard on tablet or smartphone.

#### 7.2.28 **Security**

Authentication system shall be provided to access to data. Encrypted communication channel and certification for communication to cloud and from cloud to web app shall be guaranteed. Encrypted communication channel and certification shall follow TSL protocol to ensure maximum safety level available. TSL protocol shall be provided embedded in the module for supervision and cloud connection.

#### 7.2.29 **Level of users**

It shall be possible to define at least 4 different profiles for users. Only one of the users can be identified as owner. The owner shall sign up the EULA to start the data transmission and has the rights to renew license of use. Only owner and administrator can send invitation to other users and have rights to change roles. It shall be possible to define staff profile with the rights to access to asset and device view, alerts view, analytics view and control view. It shall be possible to assign visitor profile for enabling users to access only to alerts view.

#### 7.2.30 **License and firmware update**

Transmission and access to data and analytics is set per license. License shall include automatic firmware upgrade and maintenance with life time free provisions.

7.2.31 The Specification of power and switchgear assembly (LT Panel) shall be defined by NIT authority as mentioned in Appendix I.1

### **7.3 Rising Mains**

#### 7.3.2 **Application**

- (a) The rising mains are essentially used in electrical distribution system in building 2 storied and above. These are only for indoor applications. For vertical power distribution, this is a preferred method, compared to rising cable system and is more reliable and safer from point of view of fire hazard.
- (b) Tap-off arrangements shall be provided on the rising mains with tap-off boxes.
- (c) The rising main shall comprise of sheet metal enclosure, bus bars, tap-off points, tap-off boxes, end feed units, fire barriers, expansion joints, thrust pads, end covers and fixing brackets etc.
- (d) The rising main shall conform to IS/IEC 61439-1 2011 and IS/ IEC 61439 : Part 6 : 2012 and shall be suitable for 415 V, 3 phase, 50 Hz supply and insulation of rising mains shall be capable of withstanding the voltage of 660-volt AC. Degree of IP protection and short circuit rating shall be specified.

#### 7.3.3 **Enclosure**

The enclosure shall be made from sheet steel/ALLUMINIUM of minimum 1.6 mm thickness and IK 08.

#### 7.3.4 **Bus bars**

##### (a) **Rating**

Bus bars shall be made of wrought aluminium or aluminium alloy, or electric grade copper, conforming to relevant Indian Standard, as specified. The ratings of the bus bars shall be 100A, 200A, 300A, 400A, 500A, 600A, or 800A as specified.

##### (b) **Current Density**

Bus bars shall be of sufficient cross-section so that a current density of 130A/ sq.cm (800A/sq. Inch)

is not exceeded at nominal current rating for aluminium bus bars, and 160A/sq.cm (1000A/sq. Inch) for copper bus bars. The minimum sizes of sections of bus bars are given in Table 7.1 below.

(c) **Cross Section of Bus Bars**

The cross section of the neutral bus bar shall be the same as that of the phase bus bar for bus bars of capacities up to 200A; for higher capacities, the neutral bus bar must not be less than half the cross-section of that of the phase bus bar.

(d) **Insulation**

Each bus bar shall be suitably insulated with Class B/Class F Insulation.

The insulation of the rising mains shall be capable of withstanding the voltage of 660 V of AC.

(e) **Bus Bar Supports**

Bus bar support insulators shall be class F insulators made of non- hygroscopic, non-combustible, track resistant and high strength FRP/ SMC/ DMC material, and shall be of suitable size and spacing to with-stand the dynamic stresses due to short circuit currents. The spacing between two insulators should be provided by the manufacturers according to the design approved by CPRI for their bus bar supports.

(f) **Bus Bar Clearances**

- (i) The minimum clearance to be maintained for enclosed indoor air insulated bus bars for medium voltage applications shall be as follows:

**Between Min. Clearances**

Phase to earth	26 mm
Phase to phase	32 mm

**Note:** For strip connection from bus bars to switchgear, the above clearances don't apply.

- (ii) (a) Bus bar joints shall be thoroughly cleaned and a suitable oxidizing grease shall be applied before making the joint.  
(b) High tensile bolts, plain and spring washers shall be provided to ensure good contact at the joints.  
(c) The overlap of the bus bars at the joints shall be not less than the area of the cross section of the bus bars.

(g) **Bus Bar Marking**

Bus bars and main connections shall be marked by colour or letter as per Table 7.2.

7.3.5 **Expansion Joint**

Expansion joint made of aluminium/copper strips shall be provided wherever necessary, to take care of expansion and contraction of the bus bars under normal operating conditions. This shall be invariably provided whenever the length of the rising mains exceeds 15 m.

7.3.6 **Thrust Pads**

- (a) The bus bars shall be provided with thrust pads so that the expansion of the conductors is upwards only.  
(b) The bus bar clamps and insulators shall be designed to withstand the forces due to short circuit current. They shall also permit free vertical movement of the bus bars during expansion and contraction.

7.3.7 **Mounting**

- (a) Incoming cable will be connected to the rising main through an end feed unit, consisting of switch fuse unit with MCCB/ ACB of required capacity and cable end box.

- (b) Tap-off boxes at specified intervals and height shall be provided on rising main to tap power. The box shall consist of set of MCCB/ Switch fuse unit, so that power from rising main can be switched ON/OFF and provided with suitable overload/ short circuit protection.
- (c) Distribution boards/ switch boards will not be mounted on rising main. Such boards will be separately erected on floor/ wall and connected to tap-off box with suitable copper conductor cable (See Fig. 9).

#### 7.3.8 Construction Features

- (a) The rising mains shall be manufactured in convenient sections to facilitate easy transportation and installation. The sections shall be connected to form a vertical run at site. Each section shall be provided with suitable wall straps at convenient intervals for fixing to the wall.
- (b) The enclosure shall be sturdy so as to withstand the internal and external forces resulting from the various operating conditions.
- (c) The front covers shall be detachable. Neoprene gaskets shall be provided between the covers and the side channels.
- (d) The enclosure shall have a degree of protection not less than IP 42.
- (e) The rising main shall be designed for temperature rise not exceeding 40 degrees Cover ambient temperature of 45-degree C.
- (f) Built-in fireproof barriers having 2 hr. fire rating shall be provided to restrict the spread of fire through the rising mains from one section to the adjacent section.
- (g) Necessary provisions for ventilation shall be made at suitable intervals. These shall be complete with welded non-ferrous metallic mesh to prevent entry of vermin.
- (h) Where the installation contains equipment having metal enclosures such as low-voltage switchgear and controlgear assemblies (*see* IS/IEC 61439-1 and IS/IEC 61439-2) or busbar trunking systems (IS/ IEC 60439-6), their. The metal enclosures or frames of Bus Trunking may be used as protective conductors if they simultaneously satisfy the following three requirements:
  - a) Their electrical continuity shall be assured by construction or by suitable connection so as to ensure protection against mechanical, chemical or electrochemical deterioration;
  - b) The cross-sectional area of every protective conductor shall satisfy the conditions for automatic disconnection of supply required in Table F-5 and be capable of withstanding mechanical and thermal stresses caused by the prospective fault current during the disconnection time of the protective device;
  - c) they shall permit the connection of other protective conductors at every predetermined tap-off point.
- (i) In case provision of 7.3.7(h) above could not be complied than Two numbers of copper earth strips of appropriate size shall be provided alongside the bus trunking enclosure and shall be bolted with each section of the bus trunking (Table 7.3).

#### 7.3.9 Installation of Rising Mains

- (a) Rising mains shall be installed on walls, to which the foundation bolts shall be suitably grouted (in a shaft of adequate size for rising main and floor distribution panel). The foundation bolts shall be provided by the contractor without extra payment.
- (b)
  - (i) No structural member in the building shall be damaged/ altered, without prior approval from the competent authority through the Engineer-in- charge.
  - (ii) Structural provisions like openings, cut-outs, if any, provided by the department for the work, shall be used. Where these require modifications, or where fresh provisions are required to be made, such contingent works shall be carried out by the contractor at his cost.
  - (iii) All such openings in floors provided by the Department shall be closed by the contractor after installing the cables/ conduits/ rising mains etc. as the case may be, by any suitable means as approved by the Engineer-in-charge without any extra payment.

(iv) All chases required in connection with the electrical works shall be provided and filled by the contractor at his own cost to the original architectural finish of the buildings.

### 7.3.10 Commissioning

Before connecting mains supply after installation, pre-commissioning checks comprising megger test, checking the tightness of connections, body earth connection etc. shall be carried out and recorded.

## 7.4 Bus Trunking

### 7.4.2 Application

These are generally provided for interconnections between the transformers of 400 KVA and above and DG sets of 300 KVA and above and their switch board panels, and also for interconnections between large switch board panels where specified, thereby avoiding use of large sizes of cables for such interconnections. brackets etc.

The Bus Trunking shall conform to IS/IEC 61439-1 2011 and IS/ IS/IEC 61439 : Part 6 : 2012 and shall be suitable for 415 V, 3 phase, 50 Hz supply and insulation of rising mains shall be capable of withstanding the voltage of 660-volt AC. Degree of IP protection and short circuit rating shall be specified.

### 7.4.3 Materials

#### 7.4.3.1 Enclosure

Sheet steel of minimum 2 mm thickness/ ALLUMINIUM of minimum 1.6 mm thickness and IK 08 shall be used for fabricating the enclosure.

#### 7.4.3.2 Bus Bars and Supports

Bus bars and their supports shall comply with clauses 7.3.3 of these specifications. The current rating shall be as specified in individual cases.

### 7.4.4 Construction

#### 7.4.4.1 Enclosure

- (a) The enclosure shall be of bolted type, box type, welded type or any other type as per the manufacturer's standard practice, and shall be made out from sheet steel of minimum 2 mm thickness/ ALLUMINIUM of minimum 1.6 mm thickness and IK 08.. The front cover only shall be detachable. The section of the bus duct shall be rectangular. The enclosure shall be sturdy so as to withstand the internal and external forces resulting from the various operating conditions.
- (b) The bus trunking enclosure shall be fabricated in convenient sections for easy transportation and installation. The sections shall be connected to form horizontal and vertical runs as required at site. The enclosure shall be provided with flanged ends with drilling arrangements to suit the flanges at the switchgear and transformer terminals. All flanges shall be provided with gaskets, nuts, bolts, washers etc.
- (c) The entire bus trunking enclosure shall be designed for dust and vermin proof construction. The enclosure for outdoor installation shall be additionally in weatherproof construction. The enclosure shall have a degree of protection not less than IP 42 for indoor application, and IP 54 for outdoor application in accordance with IS 2147.
- (d) Bus trunking, if required to be installed outdoors, shall be provided with a metallic protecting canopy of adequate size above the bus trunking, fabricated as part of the enclosure.
- (e) Neoprene gaskets shall be provided to satisfy the operating conditions imposed by temperature, weather etc. and durability.
- (f) Provisions for ventilation shall be made as per clause 7.3.3 of these specifications.
- (g) Where the installation contains equipment having metal enclosures such as low-voltage switchgear and control gear assemblies (see IS/IEC 61439-1 and IS/IEC 61439-2) or busbar trunking systems (IS/ IEC 60439-6), their. The metal enclosures or frames of Bus Trunking may be used as protective conductors if they simultaneously satisfy the following three requirements:

- (i) Their electrical continuity shall be assured by construction or by suitable connection so as to ensure protection against mechanical, chemical or electrochemical deterioration;
- (ii) The cross-sectional area of every protective conductor shall satisfy the conditions for automatic disconnection of supply required in Table F-5 and be capable of withstanding mechanical and thermal stresses caused by the prospective fault current during the disconnection time of the protective device;
- (iii) They shall permit the connection of other protective conductors at every predetermined tap-off point.
- (h) In case provision of 7.4.3.1(g) above could not be complied than Two numbers of copper earth strips of appropriate size shall be provided alongside the bus trunking enclosure and shall be bolted with each section of the bus trunking (Table 7.3).

#### 7.4.4.2 Expansion Joint/ Flexible Termination

- (a) Flexible connections shall be provided by braided or multi-leafed conductors for terminations at transformer bushing and switchgear.
- (b) Expansion joints shall be provided as per clause 7.3.4 of these specifications.

#### 7.4.5 Installation

- (a) Each section of the enclosure shall be suspended from the ceiling slab with suitable MS suspenders and support angles/ channels. The runs shall be neat and the route shall be as directed by the Engineer-in-charge.
- (b) The bus trunking shall be supported such that its weight does not come on the terminations.
- (c) Danger notice boards shall be provided on the bus trunking enclosure at suitable intervals in every room through which it passes.
- (d) The earthing strips shall be properly terminated to the earth bars at both ends.
- (e) Pre-commissioning checks shall be conducted.

### 7.5 Overhead Bus Bar System

#### 7.5.2 Application

The overhead bus bar system is generally used for distribution of power to a number of distributed power loads, such as motors, as in a workshop. This system has an in-built flexibility for meeting additional loads without much change in the distribution system. These specifications cover indoor application only.

#### 7.5.3 Materials

##### 7.5.3.1 Enclosure

Sheet metal used for fabrication of side channels shall be 1.6 mm thick and the top and bottom covers 1.2 mm thick.

##### 7.5.3.2 Bus Bars and Supports

- (a) The bus bars shall comply with clause 7.3.3 of these specifications. The bus bars shall however be rated for 200A, 300A or 400A as specified. Each bus bar shall be individually insulated by means of PVC sleeves.
- (b) The bus bar supports shall comply with clause 7.3.3 (e) of these specifications.

#### 7.5.4 Construction

- (a) The enclosure shall be sturdy to withstand the internal and external forces resulting from the various operating conditions. The enclosure shall have a degree of protection not less than IP 54 for indoor application and IP 65 with Canopy for outdoor application in accordance with IS 2147.
- (b) The top and bottom cover plates shall be detachable, and shall complete with gaskets to make the enclosure totally dust and vermin proof.
- (c) The enclosure shall be fabricated in convenient sections for easy transportation and installation. The bus sections shall be jointed together with flanges and tie bolts. Each section of the enclosure shall be suspended from the ceiling slab with suitable and rigid MS suspenders and brackets as required.

Detachable blank sheet steel covers shall be provided for enclosing the free ends of the bus bar run.

#### 7.5.5 Plug-in Boxes

- (i) Each section of the bus bar enclosure shall have plug-in points spaced at intervals of approximately 600 mm for the insertion of plug-in boxes.
- (ii) The plug-in boxes shall be fabricated as compact sheet steel boxes with hinged doors and shall house the fuse holders/ MCCB/ MCB. The fuse holders/ MCCB/ MCB shall be solidly connected to high conductivity copper clip-on contacts and reinforced by spring steel strips. These clip-on contacts shall plug-in directly on to the bus bars at the plug-in points.
- (iii) Two earth points shall be located at the ends of the plug-in boxes. While inserting these boxes into the plug-in points, the earth points shall engage first in the special earth bushes provided on the underside of the bus bar enclosure before the main contacts are made. While withdrawing these boxes, the earth contact is maintained even after the main contacts are isolated.
- (iv) The plug-in boxes after insertion into the plug-in points shall be fastened by wing nuts.
- (v) Each plug-in box shall be fitted with a brass compression gland suitable for the size of the cable specified. It should be possible to provide this gland in any position, i.e. left hand side, right hand side or lower side of the plug-in box.
- (vi) The unused plug-in points shall be blanked with detachable sheet steel covers.
- (vii) All contacts on joint and plug-in opening shall be silver/Tin plated copper.
- (viii) On plug-in busbar trunking there shall plug in points at required locations to meet the site requirement. This plug-in point shall have a hinged insulated click fit cover.
- (ix) All openings shall be usable simultaneously.

#### 7.5.6 Installation

- (a) The bus sections shall be jointed together with flanges and tie bolts. Each section of the enclosure shall be suspended from the ceiling slab with suitable MS suspenders and support angles/ channels as required.
- (b) Bus trunking shall be suspended at a uniform height of minimum 2.4 m above floor level. The layout shall be got approved from the Engineer-in-charge before erection.
- (c) The runs shall be straight, except at points of changes in direction.
- (d) A connector assembly shall be supplied loose with each section of the enclosure for coupling two sections, and it shall comprise a rubber locating ring, bus bar insulating tube and a connector insulating tube.

#### 7.5.7 Earthing

- (a) Where the installation contains equipment having metal enclosures such as low-voltage switchgear and controlgear assemblies (see IS/IEC 61439-1 and IS/IEC 61439-2) or busbar trunking systems (IS/ IEC 60439-6), their. The metal enclosures or frames of Bus Trunking may be used as protective conductors if they simultaneously satisfy the following three requirements:
  - (i) Their electrical continuity shall be assured by construction or by suitable connection so as to ensure protection against mechanical, chemical or electrochemical deterioration;
  - (ii) The cross-sectional area of every protective conductor shall satisfy the conditions for automatic disconnection of supply required in Table F-5 and be capable of withstanding mechanical and thermal stresses caused by the prospective fault current during the disconnection time of the protective device;
  - (iii) they shall permit the connection of other protective conductors at every predetermined tap-off point.
- (b) In case provision of 7.5.6 (a) above could not be complied than Two numbers of copper earth strips of appropriate size shall be provided alongside the bus trunking enclosure and shall be bolted with each section of the bus trunking (Table 7.3). The Copper earth strips of the bus duct shall be connected to the earth bus/ earth terminal(s) of the switchboard controlling the bus ducts, by appropriate protective conductors, notwithstanding the connection by the armoring of the feeder cable.

### 7.5.8 **Danger Notice Board**

These shall be provided on the enclosure at suitable intervals and not exceeding 5 m.

7.5.9 Pre-commissioning checks shall be conducted.

7.6 The Specification of rising main/bus trunking shall be defined by NIT authority as mentioned in Appendix I.3 and in conformity with IEC 61439-1 and IEC 61439-6.

### 7.7 **Design Verification of rising mains and bus trunking :**

#### 7.7.2 Routine verification:

Routine verification is intended to detect faults in materials and workmanship and to ascertain proper functioning of the manufactured ASSEMBLY. It is made on each ASSEMBLY. Routine verification shall be as per IEC 61439-1 & 6. Copies of the routine test certificates shall be submitted by successful tenderers.

The routine verification test are as given below:

#### (1) Construction

- (a) degree of protection of enclosures;
- (b) clearances and creepage distances;
- (c) protection against electric shock and integrity of protective circuits;
- (d) incorporation of built-in components;
- (e) internal electrical circuits and connections;
- (f) terminals for external conductors;
- (g) mechanical operation.

#### (2) Performance

- (a) dielectric properties;
- (b) wiring, operational performance and function.

#### 7.7.2.1 Design verification

Design verification and type testing shall be as per IEC 61439-1 and IEC 61439-6. The major parameters/test for design verification are mentioned in Appendix –I-4.

**TABLE 7.1**  
**Aluminium/ Copper Bus Bar Sections**  
*[Clause 7.3.3 (b)]*

Current Ratings in amps. Up to	Recommended Rectangular Cross-section			
	Aluminum		Copper	
	No. of Strips/ Phase	Size in mm	No. of Strips/ Phase	Size in mm
100	1	20 x 5	1	20 x 3
200	1	30 x 5	1	25 x 5
300	1	50 x 5	1	40 x 5
400	1	50 x 6	1	50 x 5
500	1	75 x 6	1	60 x 5
600	1	80 x 6	–	–
800	1	100 x 6	–	–

1000	1	100 x 10	–	–
1200	1	125 x 10	–	–
1600	2	100 x 10	–	–
2000	2	125 x 10	–	–
2500	3	125 x 10	–	–

**Note:**

- (i) In larger bus bars of sizes above 1000 amps, the sections can be accepted in other rectangular cross-sections and numbers also, provided the total cross-sectional area offered is not less than the total cross-sectional area shown in the above table against the respective bus bar rating.
- (ii) With aluminium bus bars, only aluminium wire/ solid bar connections shall be made for incoming/ outgoing mountings on the switchboards.
- (iii) With copper bus bars, only copper wire/ solid bar connections shall be made for incoming/ outgoing mountings on the switchboards.

**TABLE 7.2**  
[Clause 7.3.3 (g)]

**(i) Marking for A.C. Bus Bars & Main Connections**

	<b>Bus Bar and Main Connections</b>	<b>Colour</b>	<b>Letter/ Symbol</b>
(i)	Three Phase	Red, Yellow, Blue	R.Y.B.
	Two Phase	Red, Blue	R.B.
	Single Phase	Red	R
(ii)	Neutral connection	Black	N
(iii)	Connection to earth	Green	E
(iv)	Phase variable (such as connections to reversible motors)	Grey	Gy.

**(ii) For D.C. Bus Bars and Main Connections**

	<b>Bus Bar and Main Connections</b>	<b>Colour</b>	<b>Letter/ Symbol</b>
(i)	Positive	Red	R, or plus
(ii)	Negative	Blue	B, or minus
(iii)	Neutral connection	Black	N
(iv)	Connection to earth	Green	E
(v)	Equalizer	Yellow	Y
(vi)	Phase variable (such as connections to reversible motors)	Grey	Gy

**Note:** In the wiring diagram, positive and negative should be indicated by ‘+’ and ‘-’ respectively.

**TABLE 7.3**  
[Clause 7.4.3.1 (g)]

**A: Earth Continuity Strip for Protective Earthing of Sub-Station Equipment**

S. No.	Type of Installation	Earth Electrode	Earth Strip from Earth Electrode to Earth Bus and Loop Earthing of Equipment
1.	Indoor sub-station with HT panel, Transformer capacity up to 1600 KVA, LT panel, Generating set.	Copper Plate	25 x 5 mm Copper Strip
2.	Indoor sub-station with HT panel, Transformer capacity above 1600 KVA, LT panel, and Generating set.	Copper Plate	32 x 5 mm Copper Strip
3.	HT Outdoor sub-station	Copper Plate	25 x 5 mm Copper Strip
4.	LT Indoor sub-station with generator	Copper Plate	25 x 5 mm Copper Strip
5.	LT switch room having Main LT Switch Board	Copper Plate	20 x 3 mm Copper Strip

**B: Earth Continuity Strip for Bus Trunking and Rising Main**

S.No.	Type of Installation	Material of Main Conductor	Earth Strip
1.	Bus trunking capacity upto 2500 Amp	Copper/ Aluminium	2 Nos. 25 x 5 mm copper strip
2.	Bus trunking capacity Above 2500 Amp	Copper/ Aluminium	2 Nos. 32 x 5 mm copper strip
3.	Bus trunking for connecting generating set and LTpanel	Copper/ Aluminium	2 Nos. 25 x 5 mm copper strip
4.	Rising main up to 400 Amp capacity	Copper/ Aluminium	2 Nos. 20 x 3 mm copper strip
5.	Rising main above 400 Amp and up to 800 Amp capacity	Copper/ Aluminium	2 Nos. 20 x 5 mm copper strip

### C: Neutral Earthing of Transformers and Generators

S.No.	Equipment	Earth Electrode	Earth Strip from Earth Station to Neutral
1.	Transformer of capacity up to 1600 KVA	Copper plate	25 x 5 mm Copper strip
2.	Transformer of capacity above 1600 KVA	Copper plate	32 x 5 mm Copper strip
3.	Generating set of all capacity	Copper plate	25 x 5 mm Copper strip

# CHAPTER 8

## EARTHING

### 8.1 Scope

This chapter covers the essential requirements of earthing arrangement and their installation. This shall be read with Appendix F, which lays down criteria for their design. For details not covered in these specifications, IS code of Practice on Earthing (IS 3043: 2018) and NEC 2023 shall be referred to.

### 8.2 Application

8.2.1 The purpose of earthing in an installation is to provide a low earth fault loop impedance to facilitate automatic disconnection of supply in the event of a fault to exposed conductive parts, and Limit the rise of potential under earth-fault conditions of non-current carrying metal work with respect to earth to increase safety of persons and animals in proximity to such metal work.

8.2.2 Protection against electric shock both in normal service (protection against direct contact) and in case of fault (protection against indirect contact) can be achieved by several measures. The recommended fault protective measure in IS3043 to be applied in solidly earthed system is protection by automatic disconnection of supply.

Protective measure called Automatic disconnection is intended to prevent a touch voltage persisting for such time that a danger could arise. This method necessitates co-ordination of the type of system earthing, and characteristics of protective devices.

Safety against earth fault shall be achieved by implementing appropriate measure as follows:

- (a) The electrical distribution system in the Department is with solidly earthed neutral (i.e. neutral is connected to the earthing arrangement). In addition to the neutral earthing, provision is made for earthing the metallic body of equipment and non-current carrying metallic components in the substation, as well as in the internal/ external electrical installations as shown in figure F-13 A to F-13 D and explained in appendix F. Neutral shall be earthed strictly only at one location either at the point of commencement of supply or near the respective source and shall be carried out with a link.
- (b) Earthing arrangement consist of a protective equipotential bonding which shall ensure that earth fault loop impedance of each circuit is limited to a value determined by the type and current rating of the protective device used such that, on the occurrence of an earth fault, disconnection of the supply shall occur before the prospective touch voltage reaches a harmful value.
- (c) TN-S earthing system shall be followed in installations where the source such as Transformer and DG are a part of the installation and in locations where SOLAR PV or other non-conventional sources of power generation is used.
- (d) If TT earthing system is provided by the utility for an LV supply, such installation shall be protected against earth fault or earth leakages by installing an RCD whose rated residual operating current does not exceed 30 milliampere at the origin of installation. Type of RCD shall be selected based on G.2.2.2.
- (e) IT earthing systems can be adopted in locations where continuity of supply during the first fault is necessary. Insulation monitoring devices shall be installed in these cases. These locations include operation theatres in hospitals, safety services etc. Refer appendix F for more details.
- (f) For existing installations where, other systems are installed or an assessment is not possible, a TN-C-S system shall be implemented after careful analysis. To ensure that there shall be a separate Neutral conductor and protective earth conductor from the main DB downstream up to the last socket, making a TN-S system within the building. The minimum insulation resistance required between current carrying conductors to earth is 1 M $\Omega$ .
- (g) The connecting point of the EV supply equipment shall be protected by a TYPE A RCD having a rated residual operating current not exceeding 30 mA. If the EV supply equipment is equipped with a socket-outlet or vehicle connector, Type B RCD shall be used.
- (h) Lightning protection earthing shall be carried out as per Chapter 9.
- (I) Functional and equipment safety requirements of earthing

- (i) Certain application requires functional earthing, which is made by functional equipotential bonding. This is especially necessary for computer and control systems. Functional equipotential bonding is achieved by interconnecting functional earthing terminals of electronic equipment in different topologies as explained in Chapter 17 – Appendix F.
- (ii) All protective and functional earthing conductors should be connected to one single main earthing terminal.
- (iii) For buildings with large amount of sensitive and critical electronic installation such as Hospitals and Datacenters, a Mesh Bonding Network shall be adopted as per clause 4.5.4.5 of IS732.

**Note:** for more information refer ISO/IEC 30129

- (J) Earthing requirements are laid down in CENTRAL ELECTRICITY AUTHORITY (MEASURES RELATING TO SAFETY AND ELECTRIC SUPPLY) REGULATIONS 2010, as amended from time to time. These shall be complied with.
- (K) Application for Internal E.I.:
  - (i) Every sub-main will have protective conductor that run along with sub-main wiring. In case of 3-phase sub-main wiring to the final equipment, two protective conductors shall be provided to make connection to protective equipotential bonding.
  - (ii) Every circuit will have its protective conductor running along with circuit wiring. In case of 3-phase circuit to final equipment, two protective conductors shall be provided.
  - (iii) Looping of earth is allowed only in case of point wiring for light fittings and sockets. Looping is not allowed for wiring in the final circuits for electronic installations such as computers and equipment with SMPS power supply.
  - (iv) When 2/3 power outlets are looped to one circuit, earth looping of these outlets is permissible.

## 8.2 **Protective equipotential bonding, Types of Protective conductors, Earth Electrodes & Material**

Every installation shall have a protective equipotential bonding. Protective equipotential bonding shall ensure that the fault voltages in the installation are less than the tolerable limit. Buildings with steel in concrete (or using steel columns), also to be included as a part of protective equipotential bonding. For more information refer Chapter 17- Appendix F.

The requirements for earthing arrangements are intended to provide a connection to earth which:

- 8.2.1 is reliable and suitable for the protective requirements of the installation,
- 8.2.2 can carry earth fault currents and protective conductor currents to earth without danger from thermal, thermo-mechanical and electromechanical stresses and from electric shock arising from these currents,
- 8.2.3 if relevant, is also suitable for functional requirements,
- 8.2.4 is suitable for the foreseeable external influences, for example, mechanical stresses and corrosion.

Where the supply to an installation is at high voltage, requirements concerning the earthing arrangements of the high voltage supply and of the low-voltage installation shall also comply with **4.5.2** of IS 732. Power-Frequency Stress Voltages and Power-Frequency Fault Voltage in Low-Voltage System due to a fault in HV system shall conform to Table 4 of IS732.

## 8.3 **Earth fault loop impedance and safety**

- 8.3.1 The earth fault loop impedance has to be low enough to allow adequate earth fault current flow to cause an overcurrent protective device (for example, a fuse or circuit breaker) in the faulty circuit to operate in a sufficiently short time.
- 8.3.2 Earth fault loop impedance of every circuit shall be calculated during design and measured during installation, immediately after commissioning of transformer and DG.
- 8.3.3 Earth fault loop impedance of each circuit shall be limited to a value determined by the type and current rating of the protective device used such that, on the occurrence of an earth fault, disconnection of the supply shall occur before the prospective touch voltage reaches a harmful value.
- 8.3.4 Where multiple sources are used in the same installation (e.g. Transformer and DG with changeover facility), fault loop impedance shall be tested for both the sources and automatic disconnection of supply shall be ensured.
- 8.3.5 The earth resistance at each electrode shall be measured and recorded for the purpose of periodic

verification.

- 8.3.6 Where the above stated earth fault loop impedance is not achieved, necessary improvement shall be made by additional provisions, such as additional earth fault return paths and protective equipotential bonding as may be directed by the Engineer-in-charge.

#### 8.4 Marking

Different earthing symbols and its applications are included in Appendix F



- 8.4.1 Protective Earth bars/terminals at all switch boards shall be marked permanently, either as “PE” or symbol 5019.

- 8.4.2 All connections including the protective bonding connections to Main earthing terminal shall be marked “SAFETY EARTH – DO NOT DISCONNECT”.

#### 8.5 Testing

The integrity of safety by “Protective equipotential Bonding and Automatic Disconnection of supply” is ensured by testing

- Efficiency of Automatic disconnection.
  - Main and Supplementary Equipotential Bonding.
- Efficiency of Automatic Disconnection of supply is tested by measuring fault loop impedance, calculating fault current and comparing with the disconnection time of the respective protective device. While measuring fault loop impedance, attention is required for the following
- Fault loop impedance shall be measured at the final end of the circuit
  - Along with fault loop impedance, short circuit loop impedance for current carrying conductors is also a good practice.
  - Verifications recommended in IS732 / NEC (SP30: National Electrical code of India) also shall be carried out as explained in Part-1, section-17.

#### 8.6 Use of Residual Current Devices (RCDs)

An extract on selection and application of RCDs (also known as RCCBs) from IS 12640: 2008 is given at Chapter 17 - Appendix G. Provision of RCD shall be specified in individual cases keeping in view the type, use, importance, system of earthing and nature of electrical installations to be protected by the RCCBs, requirements of the local electric supply company, etc. The sensitivity shall be 30 mA or 300 mA as specified.

# CHAPTER 9

## PROTECTION OF BUILDING AGAINST LIGHTNING

### 9.1 Scope

This chapter covers the detailed requirements of installation of lightning protection system for protection of buildings, its contents and human being in the building against lightning. The principles of protection are outlined in Appendix H to these specifications. For details not covered in these specifications, reference may be made to IS/IEC 62305 (part 1 to 4) and National building code of India (NBC-2016).

**Note:** Both IS/IEC 62305 and NBC considered physical height of the air termination system. Hence devices and technologies considering virtual height of the air terminals are not considered. The NBC 2016 in PART 8 BUILDING SERVICES, Section 2 Electrical and Allied Installations in clause 11.5.1.1 mentioned “Radioactive air-terminals shall not be allowed. Any other kind of air terminals like dissipation system / ESE air-terminal / CSE air-terminal shall not be allowed”.

### 9.2 Application

This system shall be provided where specified. Risk assessment as per Chapter 17 - Appendix H shall be carried out to find out the need and level of protection. If required LPS is divided into four level classified as LPL I to LPL IV. LPL I is the highest level of lightning protection and LPL IV is for the lowest level.

### 9.3 Principal Components

The principal components of a lightning protective system are :-

- 9.3.1 Air terminations,
- 9.3.2 Down conductors,
- 9.3.3 Joint and bonds,
- 9.3.4 Testing joints,
- 9.3.5 Earth terminations, and
- 9.3.6 Earth electrodes.
- 9.3.7 Lightning equipotential bonding at the metallic service incoming into a building.
- 9.3.8 Lightning equipotential bonding at the mains incoming panel with SPD's
- 9.3.9 Protecting electrical and electronic equipment form the indirect effect of lightning by shielding, bonding and SPDs at the sub distribution panels and sometime near the equipment.

### 9.4 Materials

9.4.1 The materials of air terminations, down conductors, earth termination etc. of the protective system shall be reliably, resistant to corrosion, or be adequately protected against corrosion. The material shall be selected as per Appendix-H of Table H.10 and H.11. Subject to the corrosion conditions explained in table H-9 of Appendix- H. Earthing electrodes shall satisfy table H.11 of Appendix-H. In all cases components tested to IEC 62561 shall be preferred. The following conditions shall also be considered.

- (a) Aluminium shall be used only in exposed places and shall not be used inside concrete or soil.
- (b) Galvanized steel in soil shall not be directly connected to steel in foundation or steel embedded in concrete. This will lead to accelerated corrosion of galvanized steel. Copper, Stainless steel or Copper bonded steel shall be used for this application.
- (c) Galvanized steel shall not be embedded inside concrete.

### 9.5 Layout

9.5.1 The system design and layout shall be done in accordance with IS/IEC 62305-3 and specified in the tender documents. For new buildings Lightning Protection System embedded inside concrete shall be preferred along with Global Earthing system as per chapter 8. This method avoids the requirement of

separation distance. Conductor of suitable size and material interconnecting steel in RCC shall be used.

### 9.5.2 Air Terminations

- (a) Air termination networks may consist of vertical or horizontal conductors, or combinations of both. For the purpose of lightning protection, the vertical and horizontal conductors are considered based on the mesh, protection angle or the rolling sphere method explained in Appendix H.
- (b) For a flat roof, air termination mesh along the outer perimeter of the roof shall be used. For a roof of larger area, a network of parallel horizontal conductors shall be installed as a mesh. Maximum size of the mesh shall be as per the level of protection selected.
- (c) Horizontal air terminations should be carried along the contours such as ridges, parapets and edges of flat roofs, and, where necessary, over flat surfaces, in such a way as to join each air termination to the rest, and should themselves form a closed network.
- (d) All metallic projections including reinforcement, on or above the main surface of the roof which are connected to the general mass of the earth, should be bonded and form a part of the air termination network.
- (e) If portions of a structure vary considerably in height, any necessary air terminations or air termination network for the lower portions should be bonded to the down conductors of the taller portions, in addition to their own down conductors.

### 9.5.3 Down Conductors

- (a) The number and spacing of down conductors shall be as per the selected protection level.
- (b) Routing of Down conductors except concrete embedded down conductors
  - (i) A down conductor should follow the most direct path possible between the air terminal network and the earth termination network. The down conductors should be arranged as evenly as practicable around the outside walls of the structures.
  - (ii) Down conductors shall not be routed through any shafts.
  - (iii) Metal pipes leading rainwater from the roof to the ground may be connected to the down conductors, but cannot replace them, such connections should have disconnecting joints.
  - (iv) In deciding on the routing of the down conductor, its accessibility for inspection, testing and maintenance should be taken into consideration.
- (c) Concrete embedded down conductors or steel columns as down conductors
  - (i) Steel in RCC can be used as down conductor, provided an additional continuous conductor is super imposed in RCC during construction.
  - (ii) The continuity resistance shall be less than 0.2 ohm when tested with a meter of test current at least 10 ohms.
  - (iii) Suitable accessible points shall be available at the roof to connect these embedded down conductors to air termination system.
  - (iv) Suitable accessible points shall be available at a level above foundation to connect these embedded down conductors to earth termination system, in cases where foundation earth is not utilized.
- (d) Provision when External Route is Not Available
  - (i) Where the provision of external routes for down conductors is impracticable, for example, in buildings of cantilever construction from the first floor upwards, down conductors should not follow the outside contours of the building. To do so would create a hazard to persons standing under the overhang. In such cases, the down conductors may be housed in an air space provided by a non-metallic and non-combustible internal duct and taken straight down to the ground.
  - (ii) Any suitable covered recess, not smaller than 76 mm x 13 mm, or any suitable vertical service duct running the full height of the building may be used for this purpose, provided it does not contain an unarmoured or a non-metal sheathed cable.
  - (iii) In cases where an unrestricted duct is used, seals at each floor level may be required for fire protection. As far as possible, access to the interior of the duct should be available.

#### **9.5.4 Separation Distance**

- (a) While routing the down conductor, separation distance need to be calculated based on appendix H and maintained from live parts / services.
- (b) Separation distance is the distance required form air-termination / down-conductor and any conductive/metallic/electrical/electronic parts of a building to avoid uncontrolled flash over.

9.5.5 Lightning protective system embedded in RCC columns will not spoil the architectural or aesthetic beauty of the building. Separation distance can be ignored in this case.

### **9.6 Installation**

#### **9.6.1 General**

- (a) The entire lightning protective system should be mechanically strong to withstand the mechanical forces produced in the event of a lightning strike. The materials used shall be tested as per IEC 62561.
- (b) Conductors shall be securely attached to the building or other object to be protected, by fasteners which shall be substantial in construction, not subject to breakage, and shall be of stainless-steel materials.
- (c) The lightning conductors shall be secured as below.
  - (i) Horizontal conductor on Horizontal surface 1.0 meters
  - (ii) Horizontal conductor on vertical surface 0.5 meters for tape, stranded and soft drawn round conductors and 1.0 meters for round solid conductors
  - (iii) Vertical conductors from ground up to 20 meters 1.0 meter
  - (iv) Vertical conductors from 20 meters and thereafter, 0.5 meters for tape, stranded and soft drawn round conductors and 1.0 meters for round solid conductors
- (d) Conductors embedded in RCC shall be connected to construction steel at every 3 meter by a tested clamp, additionally bonded by a tying wire at every 1.0 meter to the steel in columns beans, slabs.

#### **9.6.2 Air Terminations**

All air terminals shall be effectively secured against overturning either by attachment to the object to be protected, or by means of substantial bracings and fixings which shall be permanently and rigidly attached to the building. The method and nature of the fixings should be simple, solid and permanent, due attention being given to the climatic conditions and possible corrosion.

#### **9.6.3 Down Conductors**

- (a) The down conductor system must, where practicable, be directly routed from the air termination to the earth termination network, and as far as possible, be symmetrically placed around the outside walls of the structure starting from the corners.
- (b) Bonding to Prevent Side Flashing  
Any metal in, or forming a part of the structure, or any building services having metallic parts which are in contact with the general mass of the earth, should be either isolated from, or bonded to the down conductor. If isolation is preferred, the minimum separation distances shall be maintained. This also applies to all exposed large metal items having any dimension greater than 2 m whether connected to the earth or not.

#### **9.6.4 Joints and Bonds**

All joints and bonds shall use components tested to IEC 62561.

##### **9.6.4.1 Joints**

- (a) A lightning protective system should have as few joints as possible.
- (b) Joints should be mechanically and electrically effective, for example, clamped, screwed, bolted, crimped, riveted or welded.
- (c) With overlapping joints, the length of the overlap should be as per the recommendation of IEC 62561
- (d) Contact surfaces should first be cleaned, and then inhibited from oxidation with a suitable non-corrosive compound.

- (e) Joints of dissimilar metals should be protected against corrosion or erosion from the elements, or the environment and should present an adequate contact area.

#### 9.6.4.2 Bonds

- (a) Bonds have to join a variety of metallic parts of different shapes and composition and cannot therefore be of a standard form.
- (b) There is the constant problem of corrosion and careful attention must be given to the metals involved, i.e. the metal from which the bond is made, and those of the items being bonded.
- (c) The bond must be mechanically and electrically effective, and protected from corrosion in, and erosion by the operating environment.
- (d) External metal on, or forming part of a structure, may have to discharge the full lightning current, and its bond to the lightning protective system should have a cross-sectional area not less than that employed for the main conductors.
- (e) Structures supporting overhead electric supply, telephone and other lines must not be bonded to a lightning protective system without the permission of the appropriate authority.
- (f) Gas pipe shall be bonded to the lightning protective earth termination system, but shall not be considered as an earth termination system.

#### 9.6.5 Test Joints

Each down conductor should be provided with a test joint in such a position that, while not inviting unauthorized interference, it is convenient for use when testing. For concrete embedded down conductors, this condition is not applicable.

#### 9.6.6 Earth Termination Network

- (a) Type A earth termination shall be preferred for small buildings with less electronics. All buildings with more than 250 Sq mtr. floor area and multi storied buildings shall use Type B earthing
- (b) In type A earthing, each down conductor is connected to a vertical or horizontal earth electrode.
- (c) Where minimum length  $l_1$  as per clause 5.4.2 of IS/IEC 62305-3 shall not be maintained, each of the earth termination system used in should have a resistance not exceeding 10 ohms. The whole of the lightning protective system, including any ring earth, should have a combine resistance to earth not exceeding 10 ohms without taking account of any bonding.
- (d) If the value obtained for the whole of the lightning protection system exceeds 10 ohms, a reduction can be achieved by extending or adding to the electrodes, or by additional ring earthing as per appendix H.
- (e) A reduction of the resistance to the earth to a value below 10 ohms has the advantage of further reducing the potential gradient around the earth electrode when discharging lightning current. It also further reduces the risk of step potential.
- (f) Earth electrodes should be capable of being isolated and a reference earth point should be provided for testing purposes.

#### 9.7 Lightning Equipotential Bonding of incoming metallic services

9.8 Down conductor / earth termination system shall be bonded to MET as per appendix H. Metal pipes (e.g. water, gas, HVAC) and incoming power and signal cables should preferably enter the building at the same place. Metal pipes and the metal armouring of cables shall be bonded to the main earthing terminal by means of conductors having low impedance; See, fig H-6 in Appendix H.

9.9 Lightning equipotential bonding and protection of electrical and electronic installations

9.9.1 Equipotential bonding of incoming power line to the installation shall be achieved by installing Type 1 Surge Protective Devices (SPD's) at the main distribution board confirming the following conditions.

- (a) The impulse current handling capacity of a set of SPD is 100 kA(10/350 $\mu$ S) for Lightning protection level 1 and 2.
- (b) The impulse current handling capacity of a set of SPD is 50 kA(10/350 $\mu$ S) for Lightning protection level 3 and 4.

- 9.9.2 Protection of electronics from transient over voltages due to lightning is achieved by installing SPDs at sub distribution board and near to electronic appliances. Installations shall be made as recommended in IS 732 clause 5.3.5
- 9.9.3 In all cases for a 230/400-volt line, the Voltage protection level of the SPD shall be  $\leq 1500$  volts. Effective protection level offered by the SPD is influenced by the wire length. Length of the connecting wires used to connect SPDs shall be max. 250 mm. For a low effective protection level, all SPD's connected between Line to Neutral or Line to Earth shall have inbuilt back up protection (e.g. inbuilt back up fuse) and shall be suitable to withstand up to 75 kA short circuit current at the mains incoming. VDE approved SPDs are preferred.
- 9.10 **Measures to Avoid Side Splashing :**  
 When a lightning protective system is struck, its electrical potential with respect to earth is raised and, unless suitable precautions are taken, the discharge may seek alternative paths to earth by side-flashing to other metal in the structure.  
 There are two different ways of preventing side flashing, namely:
- (i) Isolation, and
  - (ii) Bonding
- (a) Isolation requires large clearances between the lightning protective system and other metal in the structure. Its main drawbacks lie in the difficulty of obtaining and maintaining the necessary safe clearances and in ensuring that isolated metal has no connection with the ground, such as through water or other services. In general, isolation can only be practised in small dwelling houses and bonding is, therefore, the more commonly used method.
- (b) In bonding adjacent metalwork to the lightning protective system, careful consideration should always be given to the possible effects such bonding might have upon metal work which has been cathodically protected. The following points should be taken into account
- (i) Where a structure contains electrically continuous metal (for example a roof, wall, floor, metal cladding or curtain walling), this metal may be used as a component of the lightning protective system.
  - (ii) Where a structure is simply a continuous metal frame, it requires no air termination or down conductor. It is sufficient to ensure that the conducting path is electrically and mechanically continuous and that the requirements of the code in respect of the connection to the general mass of the earth are met.
  - (iii) A reinforced concrete structure or a reinforced concrete framed structure may have sufficiently low inherent resistance to earth to provide protection against lightning and, if connections are brought out from the reinforcement at their highest points during construction a test may be made to verify this on completion of the structure.
  - (iv) Where metal exists in a structure and it cannot be bonded into a continuous conducting network, and which is not or cannot be equipped with external earthing connections, its presence should be disregarded. The danger inseparable from the presence of such metal can be minimized by keeping it entirely isolated from the lightning protective system.
  - (v) Where the roof structure is wholly or partly covered by metal, care should be taken that such metal is provided with a continuous conducting path to earth.
  - (vi) In any structure, metal which is attached to the outer surface or projects through a wall or roof and has insufficient clearance from the lightning protective system, and is unsuitable for use as part of it, should preferably be bonded as directly as possible to the lightning protective system. If the metal runs close to an air termination network, for example water mains to storage tanks on roofs, cables, pipes, gutters, rainwater pipes, stairways, and runs approximately parallel to a down conductor or bond, it should be bonded at each end, but not below the test point. If the metal is in discontinuous lengths, each portion should be bonded to the lightning protective system; alternatively, where the clearances permit, the presence of the metal may be disregarded.
  - (vii) Metal entering or leaving a structure in the form of sheathing, armouring or piping for electric, gas, water, rain, steam, compressed air, or any other service should be bonded as directly as possible to the earth termination. This should be done near to the point at which the service enters or leaves the structure,

- (viii) Lift installation metalwork, together with all extended metal components on the inside and outside of a lift shaft, including ladders and handrails, must be bonded to the lightning conductor and to adjacent structural steel work ( the steel frame or reinforcement ), not only at the top and bottom of the lift shaft but at regular vertical intervals not exceeding 15 m .
- (ix) Where pipes/cables are protected with thermal or electrical insulation, in such cases bonding should be made to the nearest point where the metallic part of the pipe/cable becomes exposed. The bond should then be taken by as direct a route as practicable to the lightning earth outside the building.

9.11 **Protection measures to reduce failure of electrical and electronic systems:**

Possible protection measures (SPM) include :

- (i) earthing and bonding measures,
- (ii) magnetic shielding,
- (iii) line routing,
- (iv) isolating interfaces,
- (v) coordinated SPD system.

These measures may be used alone or in combination.

## CHAPTER 10

### SAFETY PROCEDURE

- 10.1 While the Central Electricity Authority (Measures relating to Safety and Electric Supply) Regulations 2023 as amended up to date, are to be followed in their entirety, particular attention is drawn to the various clauses indicated in Appendix 'C'. Any installation or portion of installation, which does not comply with these rules, should be got rectified immediately.
- 10.2 The detailed instructions on safety procedures given in BIS National Electrical code of India 2023, part 1 section 22 shall be strictly followed.
- 10.3 **Schematic Diagram**  
It shall be responsibility of the JE (E)/AE (E) to ensure that for each building, a comprehensive schematic diagram is prepared starting from the main board up to the final DBs. All such boards are to be duly marked and numbered.  
Similarly, for each campus consisting of sub-station/ sub-stations and a number of buildings, a comprehensive power distribution schematic diagram for the entire campus shall be prepared. Based on additions/ alterations such diagrams should be updated from time to time.
- 10.4 **Keep Premises Clean**  
Premises like sub-stations, switch rooms, pump house, generating rooms etc. shall be kept clean. Such premises should not be used to store broken furniture, dismantled materials, waste material, packing boxes etc.
- 10.5 **Keep all Electrical Shafts Clean and Locked**  
Such shafts should not be used for dumping floor malba etc.
- 10.6 **Protected Premises**
- 10.6.1 All premises like sub-station, pump house etc. to be maintained as protected area, admission allowed to authorized persons only.
- 10.6.2 Also, the frontage of such areas shall be kept free and parking etc. in front shall not be allowed.
- 10.6.3 No inflammable materials shall be stored in places other than the rooms specially constructed for this purpose in accordance with the provisions of Indian Explosives Act.
- 10.6.4 Rubber or insulating mats as per IS: 15652:2006 should be provided in front of the main switchboards or any other control equipment of medium voltage and above.
- 10.6.5 Protective and safety equipment such as rubber gauntlets or gloves, earthing rods, linemen's belt, portable artificial respiration apparatus etc. should be provided in each sub-station, service centre/enquiry office and important installations. Where electric welding or such other nature of work is undertaken, goggles shall also be provided.
- 10.6.6 Necessary number of caution boards such as "Man on Line, don't switch on" should be readily available in each sub-station, enquiry office and important installations.
- 10.6.7 Standard first aid boxes containing materials as prescribed by the St. John Ambulance Brigade or Indian Red Cross should be provided in each sub-station, enquiry office and important installations and should be readily available.
- 10.6.8 Periodical examination of the first aid facilities and protective and safety equipment provided at the various installations shall be undertaken for their adequacy and effectiveness and a proper record shall be maintained.

- 10.6.9 Charts (one in English and another one in the regional language) displaying methods of giving artificial respiration to a recipient of electrical shock should be prominently displayed at appropriate places.
- 10.6.10 A chart containing the names, addresses and telephone numbers of nearest authorized medical practitioners, hospitals, fire brigade and also of the officers in executive charge shall be displayed prominently along with the First Aid Box.
- 10.6.11 Executive Engineers should take immediate steps to train supervisory and authorized persons of the Engineering staff viz. A.Es, J.Es, Head Electricians, Foremen, Electricians and Wiremen in the First Aid Practices, including various methods of artificial respiration with the help of local authorities such as Fire Brigade, St. John Ambulance Brigade, Indian Red Cross or other recognized institutions equipped to impart such training, as prompt rendering of artificial respiration can save life at times of electric shock.
- 10.6.12 All new recruits should be given such First Aid Training immediately after appointment.
- 10.6.13 All supervisory and authorized persons of the Engineering staff should be deputed for refresher course in First Aid Training after every two years.
- 10.6.14 Details of preventive maintenance to be undertaken shall be in accordance with the chapter 14 of these specifications. All preventive maintenance works shall be pre- planned as far as possible and names of persons who are assigned to this work should be entered in a logbook.
- 10.6.15 Electrical wiring and control switches should be periodically inspected and any defective wiring, broken parts of switches which will expose live parts, should be replaced immediately to make the installations safe for the user.
- 10.6.16 Reports indicating details of preventive maintenance works done should be kept in a register by each Junior Engineer (E) and should bear signatures of Assistant Engineer and Executive Engineer by way of checks.
- 10.6.17 No work shall be undertaken on live installations, or on installations, which could be energized unless another person is present to immediately isolate the electric supply in case of any accident and to render first aid, if necessary.
- 10.6.18 No work of live L.T. switch board in the sub-stations should be handled by a person below the rank of a Wireman and such a work should preferably be done in the presence of the Junior Engineer (E) in charge of the work.
- 10.6.19 When working on or near live installations, suitably insulated tools should be used, and special care should be taken to see that those tools accidentally do not drop on live terminals causing shock or dead short.
- 10.6.20 The electrical switchgears and distribution boards should be clearly marked to indicate the areas being controlled by them.
- 10.6.21 Before starting any work on the existing installation, it should be ensured that the electric supply to that portion in which the work is undertaken is preferably cut off. Precautions like displaying “Men at Work” caution boards on the controlling switches, removing fuse carrier from these switches, and these fuse carriers being kept with the person working on the installation, etc. should be taken against accidental energisation. “Permit to Work” should be obtained from the Junior Engineer-in-charge. No work on H.T. main should be undertaken unless it is made dead and discharged to earth with an earthing lead of appropriate size. The discharge operation shall be repeated several times and the installation connected to earth positively before any work is started.
- 10.6.22 Before energizing on an installation after the work is completed, it should be ensured that all tools

have been removed and accounted, no person is present inside any enclosure of the switch board etc., any earthing connection made for doing the work has been removed, “Permit to Work” is received back duly signed by the person to whom it was issued in token of having completed the work and the installation being ready for re-energising and “Men at Work” caution boards removed.

- 10.6.23 In case of electrical accidents and shock, the electrical installation on which the accident occurred should be switched off immediately and the affected person should be immediately removed from the live installation by pulling him with the help of his coat, shirt, wooden rod, broom handle or with any other dry cloth or paper. He should be removed from the place of accident to a nearby safe place and artificial respiration continuously given as contained in B.I.S. Code and Standard prescribed by St. John Ambulance Brigade or Fire Brigade.
- 10.6.24 While artificial respiration on the affected person is started immediately, help of Fire Brigade and Medical Practitioner should be called for and artificial respiration should be continued uninterrupted until such help arrives.
- 10.6.25 These instructions should be explained in Hindi/local language to those staff that does not understand English.
- 10.6.26 Executive Engineers should take particular care to ensure that these instructions are imparted to the existing staff and as well as to the new entrants.

# CHAPTER 11

## FIRE HAZARDS

11.1 Requirements to protect an electrical installation from thermal effect and protection against fire due to arcing are explained in part 1, section 11 of National Electrical Code of India 2023 (NEC 2023). The provision of following codes shall be complied for avoiding fire hazards:-

- (a) 732 : 2019 Code of practice for electrical wiring installations
- (b) 17121 : 2019/IEC 62606 : 2017 General requirements for arc fault detection devices
- (c) National Electrical Code of India 2023

The main pre-requisites of a fire hazard free building are: -

11.1.1 Installation based on sound design and use of quality materials and equipment as recommended in NEC 2023.

11.1.2 Good housekeeping.

11.1.3 Proper maintenance based on skilled personnel, proper supervision and preventive maintenance.

11.1.4 Periodic inspection from fire hazard point of view by a qualified engineer.

11.1.5 The common causes of Electrical Fire are as given below:-

- (i) heat accumulation, heat radiation, hot elements;
- (ii) reduction of the safe function of electrical equipment, for example, protective devices, such as protective switchgear, thermostats, temperature limiters, seals of cable penetrations and wiring systems;
- (iii) overcurrent;
- (iv) insulation faults and/or arcs causing interference;
- (v) harmonic currents;
- (vi) lightning strikes (*see* the IS/IEC 62305 series of standards);
- (vii) overvoltage's (*see* 4.5.3 of IS 732); and
- (viii) inappropriate selection or erection of equipment

11.2 Following instructions should be followed. Besides, based on the requirement of a particular building, other instructions may be issued for avoidance of possible fire hazard.

11.2.1 No over loading of main board, DB, submain, wiring.

11.2.2 No loose wiring.

11.2.3 One socket outlet to feed one appliance only and do not use multiple outlets.

11.2.4 The AE (E) in charge will have an annual inspection of the building and list out deficiencies and report to the EE who will take necessary remedial action.

11.2.5 Only MCB type DBs to be provided. The DB's shall be designed, selected and erected so that overload, short circuit, earth fault are interrupted immediately. Rewireable type fuses not to be used.

11.2.6 Change old/ outlived wiring, switchboard, and appliance.

11.2.7 Extension to wiring/ EI only after proper design and capacity of augmentation of the existing installation (Para 1.18).

### 11.2.8 Record Room

No power outlet / switches should be provided inside the room. Use flameproof electrical fittings. In case it is a must to provide switches / outlets in a record room, they should be flameproof.

### 11.2.9 Fire Protection:

#### 11.2.9.1 Protection against Fire due to Leakage Current

Laboratory experiment shows that a leakage current above 250 mA causes fire ignitions. IS 732 have recommended for protection against such high leakage current.

Final circuits and current-using equipment shall be protected against insulation faults as follows:

- (i) In TN and TT systems, RCDs with a rated residual operating current  $I_{\Delta n}$  of 300 mA shall be used. Where resistive faults may cause a fire, for example, for overhead heating with heating film

elements, the rated residual operating current shall be  $I_{\Delta n} - 30$  mA.

- (ii) In IT systems, insulation monitoring devices monitoring the whole installation or RCMs (residual current monitoring devices) in the final circuits, both with audible and visual signals, shall be provided.

Alternatively, RCDs with a rated residual operating current as specified in a) may be used. In the event of a second fault, *see* 4.2.11 of IS 732 for disconnection times.

#### 11.2.9.2 PROTECTION AGAINST ARC FAULT

Arc fault detection devices (AFDDs) shall be used for protection against Arc fault fire hazard for household as per IS 17121.

- 11.2.9.3 Protection against Burns Accessible parts of electrical equipment within arm's reach shall not attain a temperature likely to cause burns to persons and shall comply with the appropriate limit stated below.

#### Temperature limits in Normal Service for Accessible Parts of Equipment within Arm's Reach

SI No.	Accessible Part	Material of Accessible Surface	Maximum Temperature °C
(i)	Hand-held means of operation	Metallic	55
		Non metallic	65
(ii)	Parts intended to be touched but not hand-held	Metallic	70
		Non metallic	80
(iii)	Parts which need not be touched for normal operation	Metallic	80
		Non metallic	90

- 11.2.9.4 The building should have a comprehensive fire protection system in conformity with CFO's requirement, backed by proper manning and maintenance. Additional information is available in part 4 of National Building Code of India 2016.

- 11.2.9.5 Important building will have a fire control room, for monitoring and control of fire safety of the building.

- 11.2.9.6 Local fire extinguishers for various electrical Switchgears Locations, Lift Machine Room, Electrical Sub-station, Generating Rooms, Pump Houses etc.

- 11.2.9.7 Get CFO's annual inspection of the building done.

- 11.2.9.8 Organize fire drill periodically, at least once in six months.

#### 11.2.10 Maintenance

Maintenance by qualified/ licensed (as applicable) personnel as per the requirements of CEA Regulations. When maintenance is done by contract system, only properly prequalified and skilled contractors to be deployed. Such contract should have preventive maintenance items.

Only quality and genuine material should be used.

When repairs are needed, act immediately, don't postpone repairs.

Keep telephone/ address details of Fire Station/ Police/ Hospital/ Departmental Officials/Client Department Officials, both Office and Residence (in case of emergency).

All switch rooms/ electrical shafts to be kept clean and duly locked. All locks will have common key, with keys available to all authorized personnel.

Keep appliances 'OFF' after office hours. Instruction to be issued, so that all switches and appliances are 'OFF' after office hours.

# CHAPTER 12

## ENERGY CONSERVATION

Energy is very costly. Guidelines for energy conservation are explained in Part 1 section 21 (Energy efficiency aspect) of National Electrical Code of India 2023 (NEC 2023). The following requirements are in addition to the requirements in NEC 2023:

### 12.1 Lighting and Controls

#### 12.1.1 Lighting Design

Lighting design to be done in such a way that it achieves the required visual comfort at working plane and is energy efficient. Visual comfort can be defined in terms of lux level at the working plane and energy efficiency can be defined in terms of lighting power density (Watt/m<sup>2</sup>). The recommended lux levels and lighting power densities have been specified in Chapter 2 Section 2.9.

Wherever possible, a combination of task lighting and general lighting shall be provided to get desired lighting levels. In addition to general lighting, local task luminaires shall be provided for adequate lighting level and quality in the task areas.

For general lighting, lux levels required for circulation and other non-critical applications should be maintained.

#### 12.1.2 Efficient Lamp Selection

Selection of lamp is the most important criterion for lighting design. The lamp selection should be on the basis of efficacy and good colour rendering index (CRI).

Lamps used for general lighting scheme should comply to the following:

- (a) Point Light Source – All the point light sources installed in the building for general lighting should be LED based with minimum lamp efficacy of 100 lm/W.
- (b) Linear Light Source – All the linear light sources installed in the building for general lighting should be T-5 or at least 5 Star BEE rated LED batten fittings.

Table 6 Chapter 18 lists the Wattage, luminous flux, efficacy and CRI of different types of lamps. Incandescent lamps should not be used at all.

### 12.2 Lighting Controls

#### 12.2.1 Automatic Lighting Shutoff

Interior lighting systems in buildings larger than 500 m<sup>2</sup> (5000 ft<sup>2</sup>) shall be equipped with an automatic control device. Within these buildings, all office areas less than 30 m<sup>2</sup> (300 ft<sup>2</sup>) enclosed by walls or ceiling-height partitions, all meeting and conference rooms, all school classrooms, and all storage spaces shall be equipped with occupancy sensors.

For other spaces, this automatic control device shall function on either:

- A scheduled basis at specific programmed times. An independent program schedule shall be provided for areas of no more than 2500 m<sup>2</sup> (25000 ft<sup>2</sup>) and not more than one floor,  
Or
- Occupancy sensor that shall turn the lighting off within 3 minutes of an occupant leaving the space. Light fixtures controlled by occupancy sensors shall have a wall mounted, manual switch capable to turning off lights when the space is occupied.

**Exception to above:** Lighting systems designed for 24-hour use.

#### 12.2.2 Space Control

Each space enclosed by ceiling-height partitions shall have at least one control device to independently control the general lighting within the space. Each control device shall be activated either manually by an occupant or automatically by sensing an occupant. Each control device shall

- (a) control a maximum of 250 m<sup>2</sup> for a space less than or equal to 1,000 m<sup>2</sup>, and a maximum of 1,000 m<sup>2</sup> for a space greater than 1,000 m<sup>2</sup>.
- (b) have the capability to override the shutoff control required in § 6.2.1.1 for no more than 2 hours, and

- (c) be readily accessible and located so the occupants can see the control.

Exception to § 6.2.1.2(c): The required control device may be remotely installed if required for reasons of safety or security. A remotely located device shall have a pilot light indicator as part of or next to the control device and shall be clearly labeled to identify the controlled lighting.

Each control device shall be capable of overriding the required shut off control for no more than 2 hours. It should be readily accessible and located such that the occupant can see the control.

Exception to above: The required control device may be remotely installed if required for reasons of safety or security. A remotely located device shall have a pilot light indicator as part of or next to the control device and shall be clearly labelled to identify the controlled lighting.

### 12.2.3 Day-lighting Controls

Luminaires in day lighted areas greater than 25 m<sup>2</sup> (250 ft<sup>2</sup>) shall be equipped with either a manual or automatic lighting control device that is capable of reducing lighting output of the luminaires in the day lighted areas by at least 50% and controls only the luminaires located entirely within the day lighted area.

### 12.2.4 Exterior Lighting Control

Lighting for exterior applications shall be controlled by a photo sensor or astronomical time switch that is capable of automatically turning off the exterior lighting when daylight is available or the lighting is not required.

### 12.2.5 Lighting Control Devices

Following is a description of different types of control devices available for controlling the lighting:

- (a) Timers: These are the simplest type of controls and are most popular. Some areas in buildings may require lighting for specific durations like security lighting, landscape lighting or building floodlighting. Timers allow this type of control by switching 'on' and 'off' as per pre-set times. These can have one setting (same time) for the whole year or several (seasonal/ weekly/daily) settings to take care of the changing sunset times.
- (b) Photocell Lighting Control: These measure the amount of natural light available and suitable for both indoor and outdoor applications. When available light falls below a specified level, a control unit switches the lights on (or adjusts a driver to provide more light). Photocells can be programmed so that lights do not flip on and off on partially cloudy days.
- (c) Occupancy Sensors: These devices – also known as 'motion detectors' – turn lights off and on in response to human presence. Once sensitivity and coverage area is established, sensors are selected from two predominant technology types.
- (d) Passive Infrared Sensors: These detect the motion or heat between vertical and horizontal detection zones. This technology requires a direct line of sight and is more sensitive to lateral motion, but it requires layer motion as distance from the sensor increases. The coverage pattern and field of view can also be precisely controlled. It typically finds its best application in smaller spaces with a direct line of sight, such as restrooms.
- (e) Ultrasonic Sensors: These detect movement by sensing disturbances in high-frequency ultrasonic patterns. Because this technology emits ultrasonic waves that are reflected around the room surfaces, it does not require a direct line of sight. It is more sensitive to motion towards and away from the sensor and its sensitivity decreases relative to its distances from the sensor. It also does not have a definable coverage pattern or field of view. These characteristics make it suitable for use in layer-enclosed areas that may have cabinets, shelving, partitions, or other obstructions. If necessary, these technologies can also be combined into one product to improve detection and reduce the likelihood of triggering a false on or off mode.

### **12.3 Energy Efficient Motors**

Motors shall comply with the following:

- 12.3.1 Three phase induction motors shall conform to Indian Standard (IS) 12615 and shall fulfil the following efficiency requirements:
- (a) ECBC Buildings shall have motors of IE 2 (high efficiency) class or a higher class
  - (b) ECBC+ Buildings shall have IE 3 (premium efficiency) class motors or higher class
  - (c) Super ECBC Buildings shall have IE 4 (super premium efficiency) class motors
- 12.3.2 All permanently wired polyphase motors of 0.375 kW or more serving the building and expected to operate more than 1,500 hours per year and all permanently wired polyphase motors of 50kW or more serving the building and expected to operate more than 500 hours per year, shall have a minimum acceptable nominal full load motor efficiency not less than levels specified in the latest version of IS 12615.
- 12.3.3 Motors of horsepower differing from those listed in the Chapter-18 Table 11-A to 11-H shall have efficiency greater than that of the next listed kW motor.
- 12.3.4 Motor horsepower ratings shall not exceed 20% of the calculated maximum load being served.
- 12.3.5 Motor nameplates shall list the nominal full-load motor efficiencies and the full-load power factor.
- 12.3.6 Motor users should insist on proper rewinding practices for any rewind motors. If the proper rewinding practices cannot be assured, the damaged motor should be replaced with a new, efficient one rather than suffer the significant efficiency penalty associated with typical rewind practices. Rewinding practices from BEE guideline for energy efficient motors shall be followed.
- 12.3.7 Certificates shall be obtained and kept on record indicating the motor efficiency. Whenever a motor is rewound, appropriate measures shall be taken so that the core characteristics of the motor is not lost due to thermal and mechanical stress during removal of damaged parts. After rewinding, a new efficiency test shall be performed and a similar record shall be maintained.

### **12.4 Metering**

- 12.4.1 Services exceeding 1000 KVA shall have permanently installed electrical metering to record demand (kVA), energy (kWh), and total power factor. The metering shall also display current (in each phase and the neutral), voltage (between phases and between each phase and neutral), and total harmonic distortion (THD) as a percentage of total current.
- 12.4.2 Services not exceeding 100 kVA but over 65 kVA shall have permanently installed electric metering to record demand (kW), energy (kWh), and total power factor (or kVARh).
- 12.4.3 Services not exceeding 65 kVA shall have permanently installed electrical metering to record energy (kWh).
- 12.4.4 Electrical meters shall be installed to measure the energy units generated on site through DG/ GG sets.
- 12.4.5 Separate electrical sub-meters shall be installed to measure energy consumption by HVAC plant, AHU fans and indoor lighting.
- 12.4.6 BTU meters\* shall be installed for each chiller at the entry and leaving points to measure the cooling generated by chillers.
- 12.4.7 BTU meter\* shall be installed on the chilled water loop to measure the building's total cooling demand.

\* **BTU Meter:** BTU is the acronym for British thermal unit, which is a traditional unit of energy. BTU meters are used for thermometric billing as they measure heat in terms of BTU. These meters are used for measuring energy consumption of heating and cooling systems. By installing BTU meters at individual chillers, cooling generated by individual chillers can be measured and by installing the BTU meter on the chilled water loop, building's total cooling demand can be measured.

## CHAPTER 13

### MAINTENANCE

13.1 Organized maintenance based on preventive maintenance is essential to ensure:

- (a) Un-interrupted service
- (b) No break-down
- (c) Safety, no mishaps
- (d) Economic operation
- (e) Lower energy bills
- (f) Long useful life.

13.2 Therefore, due importance is to be given for maintenance.

#### 13.3 General Guidelines

- (a) Persons engaged in maintenance works should be competent for the type of work involved and should possess necessary license. The relevant provisions of CEA Regulations should be complied with.
- (b) Safety procedures as indicated in Chapter 10 should be duly followed.
- (c) In any building, additions and alterations are bound to occur at any time. When such additions/ alterations are to be undertaken, it is very important to check in advance the likely loading of the distribution system and to strengthen the system as necessary before allowing the extra load to be connected, so as to avoid overloading of any part of the system. Even phase balancing may need to be redone so as to keep the neutral current low. To enable compliance to this safety aspect, the detailed distribution schematic diagram indicating also the wire/cable sizes, current rating of switchgear/ fuses, loading on individual circuit etc. should be available at site. This may be kept up even in a register form, with different pages for different floors/ wings, for ready reference at any time. This should be supplemented with detailed inventory.
- (d) These should be updated, as and when additions/ alterations are carried out so that the data may be fully relied upon, for further references. In fact, if any major additions alterations/ rewiring is carried out, proper record should be kept in the history book for the installation.
- (e) It is necessary that those responsible for the site maintenance should have a clear knowledge about the distribution system.
- (f) The number of items to be maintained in a building may be many like fittings, fans, DBs, earth sets etc. In order to achieve compliance to the prescribed periodicities for the various activities on them as per this schedule, each of these items may be divided into convenient numbers, to carry out the respective activities in sub periods, in a cyclic (sequential) order. For example, if DB's are to be checked every month, and there are 50 DBs in a building, these may be checked at the rate of 2 or 3 DBs every day in a sequential order (programmed in advance) so that all DBs are checked in a month.
- (g) Maintenance activities carried out as per this schedule should be noted in the Maintenance Register. When tests are carried out, the test results should be recorded with appropriate identification references (For Example: SDB7; Earth pit No.4; R/M- Wing A etc.)
- (h) The voltage of supply, total load current and PF should be noted in logbook every day, preferably during peak loading time of the day. (In the case of isolated/ unattended buildings where it is not feasible to log daily, the period may be increased to weekly or fortnightly as feasible).
- (i) If any instrument is not provided, provide the same now. If any of the instruments is defective, get it repaired early.
- (j) Inspection of electrical installations is intended primarily from fire safety considerations. Following points need to be observed as part of inspection, and corrective action as necessary should be taken immediately, including coordination with the client departments concerned, as may be required.
  - (i) Check that there is no sign of heating up, burning smell, decolouration or sparking at any of the boards (SDBs as well as main boards), and Rising Mains. These may occur due to overloading or

loose terminations. Highly unbalanced loading may cause heavy neutral currents and consequent heating of neutral conductors and terminals.

- (ii) No temporary wiring exists anywhere in the building.
  - (iii) There is no joint in cords connecting the WTAC units/ voltage regulators/office equipment like photocopier, PC etc.
  - (iv) No bare wiring exists over the flooring without mechanical protection by a metallic conduit / channel.
  - (v) There is no misuse of socket outlets, such as connecting power load to light socket, connection of multiple loads to one socket, use of heaters in record room, library etc. In such cases of additional demands of outlets, these should be provided early, after taking approval of the competent authority.
  - (vi) All DBs should be only of MCB type and all sockets for WTAC/Split units should be of industrial type controlled by MCB/Modular with MCB of suitable capacity.
  - (vii) The shafts/ spaces for electrical services are not misused, for storage or for dumping rubbish.
  - (viii) The spaces in front of DB's and sockets are free (without any storage of files/ papers etc.)
  - (ix) No additions/ alterations are done by the user departments to the electrical installations by themselves.
- (k)
- (i) A record of loading up to DB level (in each phase in case of 3 phase DBs) should be maintained, after measurements using a clip on ammeter. Such measurement should be done, as far as possible during peak season (summer and winter), when the loads are likely to be the highest.
  - (ii) The PF should be maintained above 0.8 (or any higher value fixed by the licensee without penalty). Examine the adequacy of capacitors (if any) accordingly.
  - (iii) Note down from the electricity bills, details of maximum demand, energy & PF to examine the trend of loading, penal charges if any being paid etc. (Even if the bills are paid directly by client Depts.) review of contract demand, strengthening of system, PF correction requirements etc. should be done with this review.
- (l)
- (i) While cleaning fittings and fans, the fixing/ suspending arrangements should also be checked and attended to as necessary. Care should be taken that the alignment is not disturbed.
  - (ii) In the case of ceiling fans, remove the blades, and wash the same with detergent, without causing any deformation of blade angle. Check the shackle and replace if damaged. Check that down rod is fully screwed up to the last thread on both ends and that threads are not loose. If so required, replace with new down rod of the same size, thickness and length of threading (not less than 20 mm). Check split pins and replace if any strain deformation or damage is observed. If any other system of suspension had been adopted, check the soundness of the same and tighten as necessary. Fix fan blades tightly to the body. Operate the fan at different speeds; the run should be without wobbling/ noise.
  - (iii) As per specifications, lubrication needs to be done as necessary. In such cases, the fan needs to be brought down, after removing the blades. The old grease should be replaced with a fresh one, after cleaning the bearing. If damaged, the bearing should be replaced. When reinstalling the fan, the suspension bolts should be well tightened.
- (m)
- (i) Insulation test should be done during monsoon season, as per Chapter 16 of CPWD General Specifications for Electrical Works Part I Internal, 2023.
  - (ii) Earth continuity test and earth electrode resistance test should be conducted during summer season, as per relevant clauses of CPWD specification including Chapter 16.
  - (iii) Record the test results giving identification references. If results are not satisfactory in any part of the installation, reason should be checked and corrective action be taken immediately.

## CHAPTER 14

### PREVENTIVE MAINTENANCE

- 14.1 Cleanliness is the mother of preventive maintenance. Keep areas clean.
- 14.2 Have schematic diagram for each installation.
- 14.3 No loose wiring.
- 14.4 No overloading.
- 14.5 Preventive maintenance of switchboards, DBs every six months.
- 14.6 For multi-storied building go for fuse less switchgear like ACBs, MCCBs, and MCBs, as a precaution against fire on account of short circuit.
- 14.7 Prepare preventive maintenance schedule for each installation.
- 14.8 Proper manning/ supervision of installation.
- 14.9 Maintenance of logs records and history sheet of events and breakdowns. Ensure working of all measuring and indicating instruments.
- 14.10 Take safety measures.
- 14.11 Annual inspection to ensure system adequacy, safety, efficiency and take remedial measures.
- 14.12 Replacement of old/outlived equipment.
- 14.13 Six monthly survey report of dismantled materials.
- 14.14 Display important telephone numbers.
- 14.15 Entrust repairs and maintenance to only skilled personnel and firms.
- 14.16 No short circuit to problem like patchy repairs.
- 14.17 **Compound Lighting**  
Annual painting of poles. 3 monthly cleaning of fittings. Weekly check of working of all fittings. This ensures a bright and safe premises during night.
  
- 14.18 For proper maintenance of electrical installations, the following items of work shall be carried out regularly as per periodicity stated below and a proper record of such work shall be maintained.
  - 14.18.1 Earth testing -Once in a year
  - 14.18.2 Insulation test -Once in a year
  - 14.18.3 Cleaning of E.I.
    - (a) Residential Buildings -Once in a year
    - (b) Non-residential Buildings -Once in a year
  
  - 14.18.4 Painting of E.I.**
    - (a) Residential Buildings - Once in 3 years
    - (b) Office Buildings - Once in 2 years.
    - (c) Important Public Buildings -Once in a year
    - (d) Spray painting of ceiling fans -Once in 5 years.
  
  - 14.18.5 Painting of outdoor metallic items -Once in a year like MS poles, feeder pillars etc.
  - 14.18.6 Oiling and greasing of fans -As and when required
  - 14.18.7 Checking of regulators, replacement -Once in a year. of carbon brushes etc.
  - 14.18.8 Polarity test -Once in 5 years.

# CHAPTER 15

## PAINTING

### 15.1 Scope

This chapter covers the requirements of painting work in internal electrical installations, carried out manually by brush. This does not cover spray-painting work of factory-made items.

### 15.2 Painting Work in General

#### (a) Paints

Paints, oils, varnishes etc. of approved make in original tin to the satisfaction of the Engineer-in-charge shall only be used.

#### (b) Preparation of the Surface

The surface shall be thoroughly cleaned and made free from dust or foreign matter before painting is started. The proposed surface may be inspected by the Engineer-in-charge before the paint is applied.

#### (c) Application

- (i) Paint shall be applied with brush. The paint shall be spread as smooth and even as possible. Particular care shall be paid to rivets, nuts, bolts and over-lapping. Before drawing out in smaller containers, it shall be continuously stirred with a smooth stick, while painting work is taken up.
- (ii) Primer coat of anti-corrosive paint shall be given in the case of steel work, after preparing the surface. In all cases of painting work, finishing shall be with 2 coats of paint in approved shade.
- (iii) Each coat shall be allowed to dry out sufficiently before a subsequent coat is applied.

#### (d) Precautions

All furniture, fixtures, glazing, floors etc. shall be protected by suitable covering. All stains, smears, splashing, dropping etc. shall be removed. While painting of wiring etc. it shall be ensured that the painting of wall and ceiling etc. is not spoiled in any way.

#### (e) Repainting

- (i) Painting on old surface in indoor situations will not include primer coat except where specially mentioned in the tender documents. However, where rust has formed on iron and steel surfaces, the spots will be painted with one anti-rust primer coat, after preparing the surface.
- (ii) In cases of repainting, the old paint shall be removed by first scrapping, or by applying a suitable solvent, and thereafter a fresh coat of the paint shall be applied.

### 15.3 Painting of Conduits and Accessories

- (a) Requirement of painting of metallic conduits before installation on surface shall be met as per clause 4.3.2 (i).
- (b) Requirement of painting of metallic boxes shall be as per clauses 4.2.3 (i) and 4.3.1 (iv).
- (c) After installation in surface or recess, all accessible surface of metallic conduit pipes and fittings, switch boxes and regulator boxes etc. shall be painted with two coats of enamel paint of approved shade.

### 15.4 Repainting of Ceiling Fan by Spray Painting

The spray painting of ceiling fan shall be done as per following procedure:

- (a) Clean the surface free from all foreign and harmful materials as dirt, moisture, greasy dirt, salts, rust etc. by means of any suitable detergent as required and dry the surface.
- (b) Rub down lightly with waterproof emery paper, if required in case surface is rusty and wipe off the surface using a piece of clean and dry soft cloth.
- (c) Apply one coat of finishing enamel conforming to IS 2932: 2003 uniformly by spraying and allow it to dry.

# CHAPTER 16

## VERIFICATION OF AN INSTALLATION

### 16.1 SCOPE

Verification and ensuring that the installation conforms to the predetermined conditions before/during the installation could be energized, is a necessary prerequisite under the statutory provisions. Several aspects/parameters are required to be verified before an installation could be certified as ready for energizing and use.

While a general check list of items to be inspected and necessary tests to be carried out are included in this Section. Verification shall be done as per part 1 section 17 of NEC of India 2023. Recommended resistance of conductors is additionally included in this document in this Chapter Annex A1.

In addition to initial testing, 'periodic testing and preventive maintenance checks' are necessary. Recommended maximum intervals between periodic verification, based on building occupancy type as per National Building code of India is provided in Table A-5 of this chapter.

### 16.2 INSPECTION AND TESTING

#### 16.2.1 General Requirements

Before and during the completion of the installation, or a modification to the existing installation, inspection and testing shall be carried out in accordance with IS 732 as explained in this section, for voltages up to 1000 VAC and 1500 VDC. Model forms provided in Annex A below shall be used during inspection and testing. The defects are rectified before putting electrical installation into service.

After performing all requisite pre-commissioning tests mentioned vide various specifications of individual equipment and subsequently putting the installation into service, periodic inspection and testing shall be carried out in order to maintain the installation in a sound condition. Recommended maximum intervals between periodic verification, based on type of building occupancy as per National Building code of India is provided in annex A.

Where an addition is to be made to the fixed wiring of an existing installation the latter shall be examined for compliance with recommendations of this Code.

#### 16.2.2 Inspection of the installation

Inspection shall precede testing and shall normally be done prior to energizing the installation.

The inspection shall be made to confirm that electrical equipment which is part of the fixed installation is:

- (a) In compliance with the safety requirements of the relevant equipment standards;

**NOTE**-This can be ascertained by examination of the manufacturer's information, marking or certification.

- (b) Correctly selected and erected according to IS 732 and the provisions of this code considering the manufacturer's instructions; and
- (c) Not visibly damaged or defective so as to impair safety.

#### 16.2.3 Inspection shall include at least the checking of the following, where relevant:

**NOTE** — For clause wise compliance of various inspection requirements, refer 6 of IS 732.

- (a) Method of protection against electric shock;
- (b) Presence of fire barriers and other precautions against propagation of fire & protection against thermal effects;
- (c) Selection of conductors for current-carrying capacity;
- (d) Choice, setting, selectivity and coordination of protective and monitoring devices;
- (e) Selection, location and installation of suitable overvoltage protective devices (SPD) where specified;

- (f) Selection, location and installation of suitable isolating and switching devices;
- (g) Selection of equipment and protective measures appropriate to external influences and mechanical stresses
- (h) Identification of neutral and protective conductors;
- (i) Presence of diagrams, warning notices/signs or similar information;
- (j) Identification of circuits, overcurrent protective devices, switches, terminals etc.;
- (k) Adequacy of termination and connection of cables and conductors;
- (l) Selection and installation of earthing arrangements, protective conductors and their connections;
- (m) Accessibility of equipment for convenience of operation, identification and maintenance;
- (n) Measures against electromagnetic disturbances;
- (o) Exposed-conductive-parts are connected to the earthing arrangement; and
- (p) Selection and erection of the wiring systems.

#### 16.2.4 Testing of Installation

##### (A) General

After inspection, the following tests shall be carried out, before an installation or an addition to the existing installation is put into service, any testing of the electrical installation in an already existing installation shall commence after obtaining permit to work from the engineer-in-charge and after ensuring the safety provisions.

##### (B) Low Voltage System (up to 1000 V a.c. and 1500 V d.c.)

- (i) The test methods described in this clause are mandatory. Measuring instruments and monitoring equipment and methods shall be chosen in accordance with the relevant parts of the IS/IEC 61557 series. The test and measuring equipment /instruments should periodically (as specified by relevant standards) be calibrated in authorized Test Laboratories for their accuracy.
- (ii) Some of the tests specified shall be carried out in live condition. Fault loop impedance tests require power source (e.g., transformer / DG) in live condition.
- (iii) The following tests shall be carried out where relevant and should preferably be made in the following sequence:
  - (a) Continuity resistance of conductors and verify as per Table A-1 in Annex A below. The resistance of the wires measured during testing of continuity resistance measurement of conductors shall not exceed the values mentioned in annex A.
  - (b) Insulation resistance of LV system,
  - (c) Insulation resistance testing to confirm the effectiveness of protection by SELV, PELV or electrical separation,
  - (d) insulation resistance testing to confirm the effectiveness of floor and wall resistance/impedance,
  - (e) polarity test,
  - (f) testing to confirm effectiveness of automatic disconnection of supply,
  - (g) testing to confirm the effectiveness of additional protection,
  - (h) test of phase sequence,
  - (i) functional tests,
  - (j) Voltage drop.

**NOTE:** Refer IS 732 for more information and methods for measuring the insulation resistance / impedance of floors and walls to earth or to the protective conductor, measurement of earth electrode resistance:

- (C) In the event of any test indicating failure to comply, that test and any preceding test, the results of which may have been influenced by the fault indicated, shall be repeated after the fault has been rectified. When testing in a potentially explosive atmosphere appropriate safety precaution in accordance with IS/IEC 60079-17 are necessary.

##### (D) Portable appliance test (PAT)

This test is mainly performed in respect of Class I appliances to test earth continuity of appliance from available source at power outlet to avoid risk and ensure safe working. With the help of PAT tester insulation resistance of the appliance can also be checked. Depending on test results it can be

decided whether appliance is safe for use. For continuity 0.1 ohm and Insulation resistance of 1M-ohm and above shall be considered safe.

(E) **Testing of Lightning Protection System of Buildings**

(i) General

Lightning protection verification shall be done as per IS/IEC 62305. Lightning protection levels are selected based on risk assessment calculations provided in IS/IEC 62305-2. The effectiveness of any LPS depends on its adoption of design, installation, maintenance, and testing methods explained in IS/IEC 62305-2. Inspections, testing and maintenance shall not be conducted during threat of thunderstorms.

(ii) Application of Inspections

The objective of the inspections is to ascertain that:

- (a) the LPS conforms to the design based on IS/IEC 62305,
- (b) all components of the LPS are in good condition and capable of performing their designed functions, and that there is no corrosion, and
- (c) any recently added services or constructions are incorporated into the LPS.

(iii) Order of Inspections

Inspections should be made according to 3.2.5.3 as follows:

- (a) during the construction of the structure, in order to check the embedded electrodes;
- (b) after the installation of the LPS;
- (c) earthing resistance value for the earth-termination system; and
- (d) condition of connections, equipotential bonding and fixings.

(iv) Testing

Inspection and testing of the LPS includes visual inspections and should be completed by the following actions:

- (a) performing continuity tests, especially continuity of those parts of the LPS which were not visible for inspection during the initial installation and are not subsequently available for visual inspection,
- (b) Conducting earth resistance tests of the earth-termination system. The following isolated and combined earth measurements and checks should be made, and the results recorded in an LPS inspection report.

**NOTE** — High-frequency or impulse measurements are possible and useful to determine high frequency or impulse behaviour of the earth-termination system. Such measurements may be performed at the stage of installation of the earthing system to check adequacy between the designed earthing system and the need.

- (c) The resistance to earth of each local earth electrode and were reasonably practical, the resistance to earth of the complete earth-termination system. Each local earth electrode should be measured in isolation with the test joint between the down-conductor and earth electrode in the disconnected position (isolated measurement).

**NOTE** — for earth networks incorporating both vertical earth rods and a partial or full ring earth electrode, disconnection and testing should be performed at the earth inspection pit. If such inspection is difficult to perform, routine test should be completed by high frequency or impulse tests.

- (d) If the resistance to earth of the earth-termination system as a whole exceeds 10 ohm, a check should be made to ascertain that the electrode conforms to 5.4 of IS/IEC 62305. For earth electrodes in rocky soil, the requirements of IS/IEC 62305-3 should be followed. The 10 ohm requirement is not applicable in this case.
- (e) The results of a visual check of all conductors, bonds and joints or their measured electrical continuity. If the earth-termination system does not conform to these requirements, or checking the requirements is not possible because of a lack of information, the earth-termination system should be improved by installing extra earth electrodes or installing a new earth-termination system in parallel

connectivity to existing one.

(f) SPDs need to be tested, preferably using the guidelines or equipment provided by the manufacturer.

(v) **Documentation of Inspection**

LPS inspection guides should be prepared to facilitate LPS inspections. They should contain sufficient information to guide the inspector through the inspection process so that all areas of importance are documented such as the method of LPS installation, the type and condition of the LPS components, test methods and the proper recording of the test data obtained.

The inspector should compile an LPS inspection report, which should be kept together with the LPS design report and the previously compiled LPS maintenance and inspection reports.

The LPS inspection report should contain the following information:

- (a) General conditions of air-termination conductors, and other air-termination components,
- (b) General level of corrosion and the condition of the corrosion protection,
- (c) Security of attachment of the lps conductors and components,
- (d) Earth resistance measurements of the earth-termination system,
- (e) Any deviation from the requirements of this standard,
- (f) Documentation of all changes and extension of the lps and any changes to the structure.

In addition, the LPS construction drawings and the LPS design description should be reviewed, the results of the tests performed.

**16.2.5** On completion of an electrical installation (or an extension to an installation) a certificate shall be furnished by the appropriate person in the prescribed forms in Annex A (A1 to A11), countersigned by the Engineer-in-charge/NIT Authority. This certificate in the prescribed forms of IS 732 can be used by the local electric supply authority (subject to acceptance) and form a base for electrical safety audits.

**Annexure A (A1 to A11)**  
**ANNEX A-1**

**A1 Estimation of the resistance value likely to be obtained during continuity testing.**

Table A-1 Specific Conductor Resistance  $R$  for Copper Wiring at 30°C Dependent on the Nominal Cross-sectional Area  $S$  for Rough Calculation of Conductor Resistances

**TABLE A-1**

Nominal Cross-sectional Area $S$ $\text{mm}^2$	Specific Conductor Resistance $R$ at 30°C $\text{m}\Omega/\text{m}$
1.5	12.5755
2.5	7.5661
4	4.7392
6	3.1491
10	1.8811
16	1.1858
25	0.7525
35	0.5467
50	0.4043
70	0.2817
95	0.2047
120	0.1632
150	0.1341
185	0.1091

The specific conductor resistance values are related to a conductor temperature of 30°C. For other temperatures  $\Theta$  the conductor resistances  $R_{\Theta}$  can be calculated by the use of the following formula:

$$R_{\Theta} = R_{30^{\circ}\text{C}}[1 + \alpha(\Theta - 30^{\circ}\text{C})]$$

Where:  $\Theta$  is temperature at which desired specific conductor resistance is to be calculated,

$\alpha$  is the temperature coefficient (for copper  $\alpha = 0.00393 \text{ K}^{-1}$ )

Example of calculate SCR of 16 mm<sup>2</sup> copper conductor @ 40° C the derivative will be:

$$R_{40} = 1.1858[1 + 0.00393(40 - 30)] = 1.2324$$

## Annex A-2 MODEL FORMS FOR REPORTING

General For guidance on the application of the rules initial verification, refer IS 732.

The verification report consists of Table A-2, Table A-3 and Table-A-4, out of which Table A-2 & Table A-3 are information and information at the point of commencement of supply. Appropriate table shall be selected based on the application. Detailed note for the person who produces this report and guidance for the recipient of the report is included in after the Table A-3.

Clause A-5 to A-10 indicates the subjects to be inspected on locations.

Table A-4 is recommended for Testing of the Installation

Table A-1 provides the maximum allowed resistance of copper conductors used in fixed wiring and protective bonding.

Table A-5 provides the maximum frequency of periodic verification.

### Table A-2 ELECTRICAL INSTALLATION VERIFICATION REPORT (NEW OR ALTERED INSTALLATION)

<b>DETAILS OF THE CLIENT</b>	
<b>INSTALLATION ADDRESS</b>	
<b>DESCRIPTION AND EXTENT OF THE INSTALLATION</b> Tick boxes as appropriate  Description of installation:  Extent of Installation covered by this report:  (Use continuation sheet If necessary)    see continuation sheet No: .....	New Installation <input style="width: 50px; height: 25px;" type="checkbox"/>  Addition to an Existing installation <input style="width: 50px; height: 25px;" type="checkbox"/>  Alteration to an Existing installation <input style="width: 50px; height: 25px;" type="checkbox"/>
<b>FOR DESIGN (CONSULTANT/ ENGINEER) AND NIT AUTHORITY/ENGINEER-IN-CHARGE</b>  I/We being the person(s) responsible for the design of the electrical Installation (as indicated by my/our signatures below),particulars of which are described above, having exercised reasonable skill and care when carrying out the design hereby DECLARE that the design work for which we have been responsible is to the best of my/our knowledge and belief in accordance with <b>NEC of India 2023</b> except for the departures, if any, detailed as follows:  Details of noncompliance / departures from NEC of India 2023 (clause wise to be included as a separate report):	

The extent of liability of the signatory or the signatories is limited to the work described above as the subject of this report. For the DESIGN of the installation: **\*\***(Where there is mutual responsibility for the design)

**Signature: ..... Date: ..... Name (IN BLOCK LETTERS)..... Designer No 1**

**Signature: ..... Date: ..... Name (IN BLOCK LETTERS)..... Designer No 2\*\***

**FOR CONSTRUCTION (CONTRACTOR) AND NIT AUTHORITY/ENGINEER-IN-CHARGE**

**I/We being the person(s) responsible for the construction of the electrical installation (as indicated by my/our signatures below), particulars of which are described above, having exercised reasonable skill and care when carrying out the construction hereby DECLARE that the construction work for which I/we have been responsible is to the best of my/our knowledge and belief in accordance with NEC of India 2023 except for the departures, if any, detailed as follows:**

Details of noncompliance / departures from NEC of India 2023 (clause wise to be included as a separate report):

The extent of liability of the signatory is limited to the work described above as the subject of this report. For CONSTRUCTION of the installation:

Signature: ..... Date: ..... Name (IN BLOCK LETTERS): .....Constructor

**FOR INSPECTION & TESTING (SAFETY VERIFIER) AND NIT AUTHORITY/ENGINEER-IN-CHARGE**

I/We being the person(s) responsible for the inspection & testing of the electrical installation (as indicated by my/our signatures below), particulars of which are described above, having exercised reasonable skill and care when carrying out the inspection & testing hereby DECLARE that the work for which I/we have been responsible is to the best of my/our knowledge and belief in accordance with **NEC of India 2023** except for the departures, if any, detailed as follows:

Details of noncompliance / departures from NEC of India 2023 (clause wise to be included as a separate report):

The extent of liability of the signatory is limited to the work described above as the subject of this report. For INSPECTION AND TESTING of the installation:

Signature: ..... Date: ..... Name (IN BLOCK LETTERS): ..... Inspector.

**NEXT INSPECTION**

I/We the designer(s), recommend that this installation is further inspected and tested after an interval of not more than.....years/ months.

**PARTICULARS OF SIGNATORIES TO THE ELECTRICAL INSTALLATION VERIFICATION REPORT**

**Designer (No 1)**

Name: ..... Company: .....

Address: ..... Postcode: ..... Tel No: .....

.....

**Designer (No 2) (if applicable)**

Name: ..... Company: .....

Address: ..... Postcode: ..... Tel No: .....

.....

**Constructor**

Name: ..... Company: .....

Address: ..... Postcode: ..... Tel No: .....

.....

**Inspector**

Name: ..... Company: .....

Address: ..... Postcode: ..... Tel No: .....

.....

**SUPPLY CHARACTERISTICS AND EARTHING ARRANGEMENTS - Tick boxes and enter details, as appropriate**

Earthing arrangements	Number and type of live conductors	Nature of supply parameters	Supply protective device characteristics
TN-C  TN-S  TN-C-S  TT  IT  Alternative <input type="checkbox"/> Source of supply (to be	a.c <input type="checkbox"/> d.c <input type="checkbox"/>	Nominal voltage, $U/U_0^{(1)}$ .....V Nominal frequency, $f^{(1)}$ ..Hz Prospective fault current $I_{pf}^{(2)}$ .....kA External loop impedance, $Z_e^{(2)}$ ..... $\Omega$ (Note: (1) by enquiry, (2) by enquiry calculation or measurement)	Type:   Rated current: A
	1-phase, <input type="checkbox"/> 2 pole <input type="checkbox"/> 2-wire		
	2-phase, <input type="checkbox"/> 3 pole <input type="checkbox"/> 3-wire		
	3-phase. <input type="checkbox"/> other		
	3-wire  3-phase.  4-wire		

detailed on Attached schedules)			
---------------------------------	--	--	--

**PARTICULARS OF INSTALLATION REFERRED TO IN THE REPORT** - Tick boxes and enter details, as appropriate

Means of Earthing	<b>Maximum demand</b>		
Supplier's Facility <input type="checkbox"/>	Maximum demand (load).....kVA / A Delete as appropriate		
Installation Earth Electrode <input type="checkbox"/>	<b>Details of installation earth electrode (where applicable)</b>		
	Type (e.g. rod(s), tape etc).....	Electrode resistance to earth..... $\Omega$	
	Location.....		

**Main Protective conductors**

Earthing conductor:	Material.....	csa.....mm <sup>2</sup>	continuity and connection verified	<input type="checkbox"/>
Main protective bonding Conductors:	Material.....	csa..... mm <sup>2</sup>	continuity and connection	<input type="checkbox"/>

**Main switch or circuit breaker**

Type and No. of poles.....current rating.....A      Voltage Rating.....V

Location.....      Fuse rating or setting.....A

Rated residual operating current  $I_{\Delta n}$  = .....mA, and operating time of.....ms(at  $I_{\Delta n}$ )

(applicable only where an RCD is suitable and used as a main circuit-breaker)

**RECOMMENDATIONS RELATING TO EXISTING INSTALLATION** - (in the case of an addition or alteration see 61.4.2):

**SCHEDULES**

The attached schedules are part of this document and this report is valid only when they are attached to it.....Schedules of inspections and.....Schedules of test results are attached.

(Enter quantities of schedules attached)

**Table A-3  
Electrical Installation Conditioning Report (Existing Installation for modification/ rework)**

**ELECTRICAL INSTALLATION CONDITION REPORT (Existing Installation for modification/ rework)**

**Section A. Details of the client person ordering the report**

Name: .....

Address: .....

.....

**Section B. Reason for producing this report.**

Date(s) on which inspection and testing was carried out.....

**Section C. Details of the installation which is the subject of this report**

Occupier: .....

Address: .....

Description of premises (tick as appropriate)

Domestic  Commercial  Industrial  Other (include brief description)  .....

Estimated age of wiring system.....years

Evidence of additions / alterations Yes  No  Not appare  If yes, estimate age.....years

Installation records available? Yes No  Date of last inspection.....(date)

**Section D. Extent and limitations of inspection and testing**

Extent of the electrical installation covered by this report (see 62.1.4)

Agreed limitations including the reasons (see 62.1.5).....

Agreed with: .....

Operational limitations including the reasons (see page no.....).....

.....

**The inspection and testing detailed in this report and accompanying schedules have been carried out in accordance with IEC 60364.**

**It should be noted that cables concealed within trunking and conduits, under floors and generally within the fabric of the building or underground, have not been inspected unless specifically agreed between the client and inspector prior to the inspection.**

**Section E. Summary of the condition of the installation**

General condition of the installation (in terms of electrical safety).....

Overall assessment of the installation in terms of its suitability for continued use

**SATISFACTORY / UNSATISFACTORY\* (Delete as appropriate)**

**\*An unsatisfactory assessment indicates that dangerous and/or potentially dangerous conditions have been identified.**

**Section F. Recommendations**

Where the overall assessment of the suitability of the installation for continued use above is stated as

**UNSATISFACTORY, I/we recommend that any observations classified as ‘Danger present’ (Code C1) or ‘Potentially dangerous’ (Code C2) are acted upon as a matter of urgency.**

**Investigation without delay is recommended for observations identified as ‘Requiring further investigation’.**

**Observations classified as Improvement recommended (Code C3) should be given due consideration.**

**Subject to the necessary remedial action being taken, I/ we recommend that the installation is further inspected and tested by.....(date)**

**Section G. Declaration**

**I/We, being the person(s) responsible for the inspection and testing of the electrical installation (as indicated by my/our signatures below), particulars of which are described above, having exercised reasonable skill and care when carrying out the inspection and testing, hereby declare that the information in this report, including the observations and the attached schedules, provides an accurate assessment of the condition of the electrical installation taking into account the stated extent and limitations in section D of this report.**

**INSPECTED AND TESTED BY**

Name (Capitals).....

Signature.....

For/on behalf of.....

Position.....

Address.....

Date.....

**REPORT AUTHORISED FOR ISSUE BY**

Name (Capitals) .....

Signature.....

For/on behalf of.....

Position.....

Address.....

Date.....

**Section H. Schedule(s)**

..... Schedule(s) of inspection and..... Schedule(s) of test results are attached.

**The attached schedule(s) are part of this document and this report is valid only when they are**

attached to it.

**Section I. Supply characteristics and earthing arrangements**

Earthing arrangements	Number and type of live conductors	Nature of supply parameters	Supply protective device
TN-C	a.c. <input type="checkbox"/> d.c. <input type="checkbox"/>	Nominal voltage, U/U <sub>0</sub> <sup>(1)</sup> .....v	Type.....
TN-S	1-phase <input type="checkbox"/> 2-pole <input type="checkbox"/> 2-wire	Nominal frequency, f <sup>(1)</sup> .....Hz	Rated current.....A
TN-C-S	2-phase <input type="checkbox"/> 3-pole <input type="checkbox"/> 3-wire	Prospective fault current, I <sub>pf</sub> <sup>(2)</sup> ...kA	
TT	3-phase <input type="checkbox"/> other <input type="checkbox"/> 3-wire	External loop impedance, Z <sub>e</sub> <sup>(2)</sup> ...Ω	
IT	3-phase <input type="checkbox"/> other <input type="checkbox"/> 4-wire	(Note: (1) by enquiry,(2) by enquiry, calculation or measurement)	
	Confirmation of supply polarity <input type="checkbox"/>		

Alternative source of supply (as detailed an attached schedule)

**Section J. Particulars of installation referred to in report**

Means of earthing	Details of installation earth electrode (where applicable)
Supplier's facility <input type="checkbox"/>	Type..... Location.....
Installation earth electrode <input type="checkbox"/>	Resistance to earth.....Ω

**Section K. Main protective conductors**

Earthing conductor	Material	Csa.....mm <sup>2</sup>	Connection / continuity verified <input type="checkbox"/>
Main protective bonding conductor	Material	Csa.....mm <sup>2</sup>	Connection / continuity verified <input type="checkbox"/>

To incoming Water Service	To incoming gas service	To incoming oil service	To structural steel
To lighting protection	To other incoming Service(s) Specify.....		
<b>Section L Main switch / switch-fuse / circuit breaker / RCD</b>			
Location..... Type) ..... No of poles .....	Current rating .....A Voltage rating.....V	If RCD main switch Rated residual operating current ( $I_{\Delta n}$ ).....mA Rated time delay .....ms Measured operating time (at ( $I_{\Delta n}$ ).....ms	
<b>Section M. Observations</b>			
Referring to the attached schedules of inspection and test results, and subject to the limitations specified at the <i>Extent and limitations of the inspection and testing section</i>			
No remedial action is required <input type="checkbox"/> The following observations are made <input type="checkbox"/>			
Observation(s)	Classification code	Further Investigation required (yes / no)	
.....	.....	.....	
.....	.....	.....	
.....	.....	.....	
.....	.....	.....	
.....	.....	.....	
One of the following codes, as appropriate, has been allocated to each of the observations made above to indicate to the person (s) responsible for the installation the degree of urgency for remedial action			
C 1 – Danger present. Risk of injury. Immediate action required			
C 2 – Potentially dangerous – urgent remedial action required			
C 3 – Improvement recommended			

**Annex A-3**  
**NOTES FOR THE PERSON PRODUCING THE REPORT**  
**(TABLE A-3 above)**

- a. This report also can be used for the reporting on the condition of an existing electrical installation. However, some of the tests such as continuity resistance test can be carried out on sampling basis as may be directed by the Engineer-in-charge,
- b. The report, should include schedules of both the inspection and the test results. Additional pages may be necessary for other than a simple installation. The number of each page should be indicated, together with the total number of pages involved.
- c. The maximum prospective fault current ( $I_{pf}$ ) considered should be the greater of either the short-circuit current or the earth fault current.
- d. Those elements of the installation that are covered by the report and those that are not should be identified in table A-3 (Section D: extent and limitations). These aspects should have been agreed with the person ordering the report and other interested parties before the inspection and testing is carried out. Any operational limitations, such as inability to gain access to parts of the installation or an item of equipment, should also be recorded in table A-3.
- e. The summary of condition of the installation in terms of safety should be clearly indicated in section E. Observation(s), if any, should be categorized in section M (Table A-3) using the coding **C-1** to **C-3** as appropriate. Any observation given a **C-1** or **C-2** classification should result in the overall condition of the installation being reported as unsatisfactory.
- f. Where an installation has an alternative source of supply a further schedule of supply characteristics and earthing details based upon Section I of Table A-3 of this report should be provided.
- g. Where an observation requires further investigation because the inspection has revealed an apparent deficiency which could not, owing to the extent or limitations of this inspection, be fully identified, this should be indicated in the column headed "Further investigation required" within section M of Table A-3).
- h. The date by which the next electrical installation condition report is required should be given in Section F of Table A-3). The interval between inspections should take into account the type and usage of the installation and its overall condition.
- i. If the space available for observations in Section M of Table A-3) is insufficient, additional pages should be provided as necessary.
- j. Wherever practicable, items classified as 'Danger present' (C1) should be made safe on discovery. Where this is not practical the owner or user should be given written notification as a matter of urgency.

**Annex A - 4**  
**GUIDANCE FOR RECIPIENTS**  
**(Table A-3 above) (To be appended to the report)**

**This report is an important and valuable document which should be retained for future reference.**

This report form is for reporting on the condition of an existing electrical installation.

- a. The purpose of this condition report is to confirm, so far as reasonably practicable, whether or not the electrical installation is in a satisfactory condition for continued service (*see* section E of Table A-3). The report should identify any damage, deterioration, defects and/or conditions which may give rise to danger (*see* section M of Table A-3).
- b. The person ordering the report should have received the original report and the inspector should have retained a duplicate.
- c. The original report should be retained in a safe place and be made available to any person inspecting or undertaking work on the electrical installation in the future. If the property is vacated, this report will provide the new owner /occupier with details of the condition of the electrical installation at the time the report was issued.
- d. Section D of Table A-3 (extent and limitations) should identify fully the extent of the installation covered by this report and any limitations on the inspection and testing. The inspector should have agreed these aspects with the person ordering the report and with other interested parties (licensing authority, insurance company, mortgage provider and the like) before the inspection was carried out.
- e. Some operational limitations such as inability to gain access to parts of the installation or an item of equipment may have been encountered during the inspection. The inspector should have noted these in Section D of Table A-3.
- f. For items classified in Section M of Table A-3 as C1 (“Danger present”), the safety of those using the installation is at risk, and it is recommended that a competent person undertakes the necessary remedial work immediately.
- g. For items classified in Section M of Table A-3 as C2 (“Potentially dangerous”), the safety of those using the installation may be at risk and it is recommended that a competent person undertakes the necessary remedial work as a matter of urgency.
- h. Where it has been stated in Section M that an observation requires further investigation the inspection has revealed an apparent deficiency which could result in a code C1 or C2 item that could not, due to the extent or limitations of the inspection, be fully identified. In such cases a further examination of the installation will be necessary, without delay, to determine the nature and extent of the apparent deficiency. (*see* Section F of Table A-3).
- i. For safety reasons, the electrical installation will need to be re-inspected at appropriate intervals by a competent person. The recommended date by which the next inspection is due is stated in Section F of Table A-3 of the report under ‘Recommendations’.

## Annex A-5

# SUBJECTS OF INSPECTION IN ELECTRICAL INSTALLATIONS

### **A-5.1 Schedule for Items Requiring Inspection for Initial Verification of an Electrical Installation.**

All items inspected in order to confirm compliance with the relevant clauses in the IS 732. The list of items is not exhaustive.

#### **A-5.1.1 Electrical Intake Equipment**

- a. Service cable;
- b. Service cut-out / fuse/ Incoming circuit breaker;
- c. Meter tails – Energy supplier (applicable for LV installation);
- d. Meter tails – Consumer;
- e. Metering equipment; and
- f. Isolator.

#### **A-5.1.2 Parallel or Switched Alternative Sources of Supply**

- a. Dedicated earthing arrangement independent to that of the public supply;
- b. Presence of adequate arrangements where generator to operate in parallel with the public supply system;
- c. Correct connection of generator in parallel;
- d. Compatibility of characteristics of means of generation;
- e. Means to provide automatic disconnection of generator in the event of loss of public supply system or voltage or frequency deviation beyond declared values;
- f. Means to prevent connection of generator in the event of loss of public supply system or voltage or frequency deviation beyond declared values; and
- g. Means to isolate generator from the public supply system.

#### **A-5.1.3 Automatic Disconnection of Supply**

Main earthing / bonding arrangements

- a) Presence and adequacy of:
  1. Distributor's earthing arrangement or installation earth electrode arrangement;
  2. Earthing conductor and connections;
  3. Main protective bonding conductors and connections; and
  4. Earthing / bonding labels at all appropriate locations.
- b) Accessibility of:
  1. Earthing conductor connections;
  2. All protective bonding connections; and
  3. FELV – requirements satisfied.

### **A-5.2 Other Methods of Protection**

**NOTE:** Where any of the methods listed below are employed details should be provided on separate pages.

#### **A-5.2. Basic and Fault Protection**

Where used, confirmation that the requirements are satisfied:

- a) SELV,
- b) PELV,
- c) Double insulation, or
- d) Reinforced insulation.

#### **A-5.2.2 Basic Protection**

- a) Insulation of live parts,
- b) Barriers or enclosures,

- c) Obstacles, or
- d) Placing out of reach.

**A-5.2.3 Fault Protection**

- a) Non-conducting location – earth-free local equipotential bonding, and
- b) Electrical separation.

**A-5.2.4 Additional Protection**

- a) RCDs not exceeding 30 mA as specified; and
- b) Supplementary bonding.

## **Annex A-6**

### **SPECIFIC INSPECTION EXAMPLES**

As appropriate to the installation

#### **A-6.1 Distribution Equipment**

- a) Adequacy of working space / accessibility to equipment;
- b) Security of fixing;
- c) Insulation of live parts not damaged during erection;
- d) Adequacy / security of barriers;
- e) Suitability of enclosures for IP and fire ratings;
- f) Enclosures not damaged during installation;
- g) Presence and effectiveness of obstacles;
- h) Placing out of reach;
- j) Presence of main switch(es), linked where required;
- k) Operation of main switch(es) (functional check);
- m) Manual operation of circuit-breakers and RCDs to prove functionality;
- n) Confirmation that integral test button / switch causes RCD(s) to trip when operated (functional check);
- p) RCD(s) provided for fault protection, where specified;
- q) RCD(s) provided for additional protection, where specified;
- r) Confirmation over-voltage protection (SPDs) provided where specified;
- s) Confirmation of indication that SPD is functional;
- t) Presence of RCD quarterly test notice at or near the origin;
- u) Presence of diagrams, charts or schedules at or near each distribution board, where required; and
- v) Presence of non-standard (mixed) cable colour warning notice at or near the appropriate distribution board, where required.

#### **A-6.2 Presence of Alternative Supply Warning Notice at or Near**

- a) The origin,
- b) The meter position, if remote from origin,
- c) The distribution board to which the alternative/additional sources are connected,
- e) All points of isolation of ALL sources of supply,
- f) Presence of next inspection recommendation label,
- g) Presence of other required labelling,
- h) Selection of protective device(s) and base(s); correct type and rating,
- j) Single-pole protective devices in line conductor only,
- k) Protection against mechanical damage where cables enter equipment,
- m) Protection against electromagnetic effects where cables enter ferromagnetic enclosures, and
- n) Confirmation that all conductor connections, including connections to busbars are correctly located in terminals and are tight and secure.

#### **A-6.3 Circuits**

- a) Identification of conductors;
- b) Cables correctly supported throughout;
- c) Examination of cables for signs of mechanical damage during installation;
- d) Examination of insulation of live parts, not damaged during erection;
- e) Non-sheathed cables protected by enclosure in conduit, ducting or trunking;
- f) Suitability of containment systems (including flexible conduit);
- g) Correct temperature rating of cable insulation;
- h) Cables correctly terminated in enclosures;
- j) Adequacy of cables for current-carrying capacity with regard for the type and nature of installation;
- k) Adequacy of protective devices: type and fault current rating for fault protection ;
- m) Presence and adequacy of circuit protective conductors;

- n) Coordination between conductors and overload protective devices;
- p) Wiring systems and cable installation methods / practices with regard to the type and nature of installation and external influences; and
- q) Cables concealed under floors, above ceilings, in walls adequately protected against damage by contact with fixings.

#### **A-6.4 Provision of Additional Protection by RCDs Having Residual Rated Operating Current ( $I_{\Delta n}$ ) Not Exceeding 30mA**

- a) For circuits used to supply mobile equipment not exceeding 32 A rating for use outdoors in all cases;
- b) For all socket-outlets of rating 20 A or less provided for use by ordinary persons unless exempt;
- c) For cables concealed in walls at a depth of less than 50 mm;
- d) Provision of fire barriers, sealing arrangements so as to minimize the spread of fire;
- e) Band II cables segregated / separated from Band I cables; and
- f) Cables segregated / separated from non-electrical services.

#### **A-6.5 Termination of Cables at Enclosures**

- a) Connections under no undue strain;
- b) No basic insulation of a conductor visible outside enclosure;
- c) Connections of live conductors adequately enclosed;
- d) Adequately connected at point of entry to enclosure (glands, bushes etc.);
- e) Suitability of circuit accessories for external influences;
- f) Circuit accessories not damaged during erection;
- g) Single-pole devices for switching in line conductor only;
- h) Adequacy of connections, including CPCs, within accessories and fixed and stationary equipment; and
- j) Presence, operation and correct location of appropriate devices for isolation and switching.

## **Annex A-7**

# **ISOLATION AND SWITCHING**

### **A-7.1 Isolators**

- a) Presence and location of appropriate devices;
- b) Capable of being secured in the OFF position;
- c) Correct operation verified (functional check);
- d) The installation, circuit or part thereof that will be isolated is clearly identified by location and / or durable marking; and
- e) Warning label posted in situations where live parts cannot be isolated by the operation of a single device.

### **A-7.2 Switching Off for Mechanical Maintenance**

- a) Presence of appropriate devices;
- b) Acceptable location – state if local or remote from equipment in question;
- c) Capable of being secured in the Off position;
- d) Correct operation verified (functional check); and
- e) The circuit or part thereof that will be disconnected clearly identified by location and / or durable marking.

### **A-7.3 Emergency Switching /Stopping**

- a) Presence and location of appropriate devices;
- b) Readily accessible for operation where danger might occur;
- c) Correct operation verified (functional check); and
- d) The installation, circuit or part thereof that will be disconnected clearly identified by location and / or durable marking.

### **A-7.4 Functional Switching**

- a) Presence and location of appropriate devices; and
- b) Correct operation verified (functional check).

**Annex A-8**  
**CURRENT-USING EQUIPMENT**  
**(PERMANENTLY CONNECTED)**

- a) Suitability of equipment in terms of IP and fire ratings;
- b) Enclosure not damaged / deteriorated during installation so as to impair safety;
- c) Suitability for the environment and external influences;
- d) Security of fixing;
- e) Cable entry holes in ceilings above luminaires, sized or sealed so as to restrict the spread of fire;
- f) Provision of under-voltage protection, where specified; and
- g) Provision of overload protection, where specified.

**A-8.1 Recessed Luminaires (Downlighters)**

- a) Correct type of lamps fitted; and
- b) Installed to minimize build-up of heat by use of “fire rated” fittings, insulation displacement box or similar.

**Annex A-9**  
**SPECIAL INSTALLATIONS OR LOCATIONS**  
(see Part 3 of this code)

If any special installations or locations are present, list the particular inspections applied.

**A-9.1 Model Inspection Schedule of Items Requiring Inspection for an Existing Electrical Installation**

A visual inspection should firstly be made of the external condition of all electrical equipment which is not concealed.

Further detailed inspection, including partial dismantling of equipment as required, should be carried out as agreed with the person ordering the work.

The list of items is not exhaustive.

**A-9.2 Electrical Intake Equipment**

- a) Service cable;
- b) Service cut-out / fuse;
- c) Meter tails – Distributor;
- d) Meter tails – Consumer;
- e) Metering equipment; and
- f) Isolator.

Where inadequacies in distributor's equipment are encountered, it is recommended that the person ordering the report informs the appropriate authority.

**A-9.3 Presence of Adequate Arrangements for Parallel or Switched Alternative Sources**

**A-9.4 Automatic Disconnection of Supply**

- a) Main earthing / bonding arrangements;
- b) Presence of distributor's earthing arrangement or presence of installation earth electrode arrangement;
- c) Presence and adequacy of earthing conductor;
- d) Main protective earthing conductor connections;
- e) Accessibility of earthing conductor connections;
- f) Presence and adequacy of main protective bonding conductors;
- g) Main protective bonding conductor connections;
- h) Accessibility of all protective bonding connections;
- j) Provision of earthing / bonding labels at all appropriate locations; and
- k) FELV.

**A-9.5 Other Methods of Protection**

Where any of the methods listed below are employed, details should be provided on separate sheets.

**A-9.5.1 Basic and Fault Protection**

- a) SELV;
- b) PELV;
- c) Double insulation; or
- d) Reinforced insulation.

**A-9.5.2 Basic Protection**

- a) Insulation of live parts;
- b) Barriers or enclosures;

- c) Obstacles; and
- d) Placing out of reach.

### **A-9.5.3 Fault Protection**

- a) Non-conducting location – earth-free local equipotential bonding; and
- b) Electrical separation.

### **A-9.5.4 Additional Protection**

- a) RCDs 30 mA or less as specified; and
- b) Supplementary bonding.

## **A-9.6 Specific Inspection Examples**

### **A-9.6.1 Distribution Equipment**

- a) Adequacy of working space / accessibility to equipment;
- b) Security of fixing;
- c) Condition of insulation of live parts;
- d) Adequacy / security of barriers;
- e) Condition of enclosure(s) in terms of IP and fire ratings;
- f) Enclosure not damaged / deteriorated so as to impair safety;
- g) Presence and effectiveness of obstacles;
- h) Placing out of reach;
- j) Presence of main switch(es), linked where required;
- k) Operation of main switch(es) (functional check);
- m) Manual operation of circuit-breakers and RCDs to prove disconnection;
- n) Confirmation that integral test button / switch causes RCD(s) to trip when operated (functional check);
- p) RCD(s) provided for fault protection;
- q) RCD(s) provided for additional protection, where required;
- r) Confirmation of indication that over-voltage protection (SPDs) is functional, where installed;
- s) Presence of RCD quarterly test notice at or near equipment, where required;
- t) Presence of diagrams, charts or schedules at or near equipment, where required;
- u) Presence of non-standard (mixed) cable colour warning notice at or near equipment, where required;
- v) Presence of alternative supply warning notice at or near equipment, where required;
- w) Presence of next inspection recommendation label;
- y) Presence of other required labelling (please specify);
- z) Examination of protective device(s) and base(s); correct type and rating (no signs of unacceptable thermal damage, arcing or overheating);
- aa) Single-pole protective devices in line conductor only;
- ab) Protection against mechanical damage where cables enter equipment;
- ac) Protection against electromagnetic effects where cables enter ferromagnetic enclosures; and
- ad) Confirmation that all conductor connections, including connections to busbars are correctly located in terminals and are tight and secure.

### **A-9.6.2 Circuits**

- a) Identification of conductors;
- b) Cables correctly supported throughout;
- c) Condition of cables;
- d) Condition of insulation of live parts;
- e) Non-sheathed cables protected by enclosure in conduit, ducting or trunking;
- f) Suitability of containment systems for continued use (including flexible conduit);
- g) Cables correctly terminated in enclosures;
- h) Examination of cables for signs of unacceptable thermal or mechanical damage / deterioration;
- j) Adequacy of cables for current-carrying capacity with regard for the type and nature of installation;

- k) Adequacy of protective devices: type and rated current for fault protection;
- m) Presence and adequacy of circuit protective conductors;
- n) Coordination between conductors and overload protective devices;
- p) Wiring systems and cable installation methods / practices with regard to the type and nature of installation and external influences;
- q) Where exposed to direct sunlight, cable of a suitable type; and
- r) Cables concealed under floors, above ceilings, in walls adequately protected against damage by contact with fixings.

**A-9.6.3 Provision of Additional Protection by RCDs having Residual Rated Operating Current ( $I_{\Delta n}$ ) not Exceeding 30 mA**

- a) For circuits used to supply mobile equipment not exceeding 32 A rating for use outdoors in all cases;
- b) For all socket-outlets of rating 20 A or less provided for use by ordinary persons unless exempt;
- c) For cables concealed in walls at a depth of less than 50 mm;
- d) Provision of fire barriers, sealing arrangements and protection against thermal effects;
- e) Band II cables segregated / separated from Band I cables;
- f) Cables segregated / separated from non-electrical services; and
- g) Condition of circuit accessories.

**A-9.6.4 Termination of Cables at Enclosures – Identify /Record Numbers and Locations of Items Inspected**

- a) Connections under no undue strain;
- b) No basic insulation of a conductor visible outside enclosure;
- c) Connections of live conductors adequately enclosed;
- d) Adequately connected at point of entry to enclosure (glands, bushes etc.);
- e) Suitability of circuit accessories for external influences;
- f) Condition of accessories including socket-outlets, switches and joint boxes;
- g) Single-pole devices for switching in line conductor only;
- h) Adequacy of connections, including CPCs, within accessories and fixed and stationary equipment;
- j) Presence, operation and correct location of appropriate devices for isolation and switching;
- k) General condition of wiring systems; and
- m) Temperature rating of cable insulation.

**A-9.7 Isolation and Switching**

**A-9.7.1 Isolators**

- a) Presence and condition of appropriate devices;
- b) Acceptable location – state if local or remote from equipment in question;
- c) Capable of being secured in the OFF position;
- d) Correct operation verified;
- e) Clearly identified by position and /or durable marking; and
- f) Warning label posted in situations where live parts cannot be isolated by the operation of a single device

**A-9.7.2 Switching Off for Mechanical Maintenance**

- a) Presence and condition of appropriate devices;
- b) Acceptable location – state if local or remote from equipment in question;
- c) Capable of being secured in the OFF position;
- d) Correct operation verified; and
- e) Clearly identified by position and /or durable marking.

**A-9.7.3 Emergency Switching /Stopping**

- a) Presence and condition of appropriate devices;
- b) Readily accessible for operation where danger might occur;

- c) Correct operation verified; and
- d) Clearly identified by position and /or durable marking.

#### **A-9.7.4 Functional Switching**

- a) Presence and condition of appropriate devices; and
- b) Correct operation verified.

#### **A-9.8 Current–Using Equipment (Permanently Connected)**

- a) Condition of equipment in terms of IP and fire ratings;
- b) Enclosure not damaged / deteriorated so as to impair safety;
- c) Suitability for the environment and external influences;
- d) Security of fixing;
- e) Cable entry holes in ceiling above luminaires, sized or sealed so as to restrict the spread of fire;
- f) Condition and provision of under-voltage protection, where required; and
- g) Condition and provision of over-load protection, where required.

#### **A-9.9 Recessed Luminaires (Down lighters)**

- a) Correct type of lamps fitted;
- b) Installed to minimise build-up of heat by use of “fire rated” fittings, insulation displacement box or similar;
- c) No signs of overheating to surrounding building fabric and
- d) No signs of overheating to conductors / terminations.

#### **A-10 If any special installations or locations are present, list the particular inspections applicable**

**Table A-4**  
**MODEL SCHEDULE OF CIRCUIT DETAILS AND TEST RESULTS**

<b>Distribution board details</b> Reference..... ..... Location..... ..... Zs..... ..... $\Omega$ Ipf..... .....kA Correct supply polarity confirmed ( <input type="checkbox"/> or X)		<b>Details of circuits and/or installed equipment vulnerable to testing</b> ..... ..... ..... .....		<b>Details of test instruments used (state serial no or other unique identifier)</b> Continuity ..... Insulation resistance..... Earth fault loop impedance..... RCD..... Earth electrode resistance.....			
Tested by (Capitals) ..... Signature.....Date:..... .....		<b>Test results</b>					
<b>Circuit details</b>		<b>Continuity (<math>\Omega</math>)</b>	<b>Insulation Resistance (M<math>\Omega</math>)</b>	<b>Polarity ( or X)</b>	<b>Zs (<math>\Omega</math>)</b>	<b>RCD</b>	
	<b>Overcurrent t</b>	<b>Conductor details</b>	<b>[(R1+R2) or {R2}]</b>				

Circuit number	Circuit description	Standard number	Type	Rating (A)	Breaking Capacity (kA)	Installation Reference Method	Cross sectional area (mm <sup>2</sup> )		(R <sub>1</sub> +R <sub>2</sub> )	R <sub>2</sub>	L - L	L - E			Sensitivity (IΔn)	Operating time (ms)		Test Button Operation	Remarks (continue on separate sheet if required)
							Live	cpc								@ IΔn	@ 5IΔn		
1	2	3	4	5	6	7	8	9	10	11	12	13	14	15	16	17	18	19	20

**Table A-5**  
**TABLE FOR MODEL SCHEDULE OF CIRCUIT DETAILS AND TEST RESULTS**

**(Recommended maximum intervals between periodic verification (in years))**

Category	Occupancy type as per NBC of India:2016.(For detailed description, refer NBC: part4, fire and life safety, Table7)	Frequency of periodic verification in years (y) based on height(h) of buildings	
		<15 (h)	>15 (h)
Group A	Residential	<15 (h)	>15 (h)
A1, A2	Lodging and rooming houses, One-or two-private	10 (y)	NA
A3, A4	Dormitories, Apartment Houses	10 (y)	5 (y)
A5	Hotels	5 (y)	3 (y)
A6	Starred hotels	2 (y)	
Group B	Educational	<15 (h)	>15 (h)
B1, B2	Schools, all other/ training institutions	3 (y)	2 (y)
Group C	Institutional	<10 (h)	>10 (h)
C1	Hospitals and sanatoria(IPD/OPD)	2 (y)	
C2	Custodial institutions	5 (y)	3 (y)
C3	Penal and mental institutions	3 (y)	
Group D	Assembly	<10 (h)	>10 (h)
D1to D6	Theatre/ Cinema, accommodation, temporary and other structures, mixed-assembly and mercantile	3 (y)	2 (y)
D7	UG/elevated mass rapid transit system	2 (y)	
Group E	Business	<10 (h)	>10 (h)
E1toE5	Offices, laboratories, clinics, libraries, IT parks, telephone exchange, broad casting and TV stations	3 (y)	2 (y)
Group F	Mercantile	<15 (h)	>15 (h)
F1,F2	Shops, stores	3 (y)	2 (y)
F3	UG shopping centers & service centers in same	2 (y)	
Group G	Industrial	Any height	
G1	Low hazard	5 (y)	
G2	Moderate hazard	3 (y)	
G3	High hazard	1 (y)	
Group H	Storage, e.g. ware houses, cold storages, truck and	1 (y)	
Group J	Hazardous	1	

**CHAPTER 17**  
**APPENDIX A**  
**TERMINOLOGY**

[Clause 1.3.1]

This appendix indicates some of the commonly used and important terms, relevant for the Internal EI works. For complete list of terms, relevant IS may be referred to.

1)	<b>Ambient Temperature</b> — The temperature of the air or other medium where the equipment is to be used.
2)	<b>Appliance</b> — An item of current-using equipment other than a luminaire or an independent motor.
3)	<b>Are-Luminous discharge</b> of electricity across an insulating medium, usually, accompanied by the partial volatilization of the electrodes
4)	<b>Basic Insulation</b> — Insulation applied to live parts to provide basic protection against electric shock and which does not necessarily include insulation used exclusively for functional purpose.
5)	<b>Back-up Protection</b> — Protection which is intended to operate when a system fault is not cleared or abnormal condition not detected in the required time, because of failure or inability of other protection to operate or failure of appropriate circuit-breaker to trip.
6)	<b>Basic Protection</b> — Protection against electric shock under fault-free condition. NOTE — For low voltage installations, systems and equipment, basic protection generally corresponds to protection against direct contact that is “contact of persons or live parts”.
7)	<b>Bonding Conductor</b> — A protective conductor providing equipotential bonding.
8)	<b>Bunched</b> — Cables are said to be bunched when two or more cables are contained within a single conduit, duct, ducting, or trunking or, if not enclosed, are not separated from each other.
9)	<b>Busbar Trunking System</b> — A type-tested assembly, in the form of an enclosed conductor system comprising solid conductors separated by insulating materials. The assembly may consist of units such as: a) Busbar trunking units, with or without tap-off facilities; b) Tap-off units where applicable; and c) Phase-transposition, expansion, building movement, flexible, end-feeder and adaptor units.
10)	<b>Cable</b> — A length of single-insulated conductor (solid or stranded), or two or more such conductors, each provided with its own insulation, which are laid up together. The insulated conductor or conductors may or may not be provided with an overall mechanical protective covering.
11)	<b>Cable Tray</b> — A cable support consisting of a Continuous base with raised edges and no covering. A cable tray is considered to be non-perforated, where less than 30 percent of the material is removed from the base.
12)	<b>Circuit</b> —An assembly of electrical equipment supplied from the same origin and protected against over current by the same protective devices. Certain types of circuit are categorized as follows: a) Category 1 Circuit — A circuit (other than a fire alarm or emergency lighting circuit) operating at low voltage and supplied directly from a mains supply system. b) Category 2 Circuit — With the exception of fire alarm and emergency lighting circuits, any circuit for telecommunication (for example, radio, telephone, sound distribution, intruder alarm, bell, call and data transmission circuits)which is supplied from a safety. c) Category 3 Circuit — A fire alarm circuit or an emergency lighting circuit.

13)	<b>Circuit Breaker</b> — A mechanical switching device capable of making, carrying and breaking currents under normal circuit conditions and also of making, carrying for as specified, and breaking currents under specified abnormal circuit conditions such as those of short circuit. <b>NOTE</b> — A circuit breaker is usually intended to operate infrequently, although some types are suitable for frequent operation.
14)	<b>Class-I-Equipment</b> — Equipment in which protection against electric shock does not rely on basic insulation only, but which includes an additional safety precaution in such a way that means are provided for the connection of exposed conductive parts to a protective conductor in the fixed wiring of installation in such a way that accessible conductive parts may not become live in the event of a failure of basic insulation. <b>NOTE</b> — For information on classification of equipment with regard to means provided for protection against electric shock, see IEC 61140.
15)	<b>Class-II-Equipment</b> — Equipment in which protection against electric shock does not rely on basic insulation only, but in which additional safety precautions, such as double or reinforced insulation are provided, there being no provision for the connection of exposed metal work of the equipment to a protective conductor, and no reliance upon precautions to be taken in the fixed wiring of the installation.
16)	<b>Class-III-Equipment</b> — Equipment in which protection against electric shock relies on supply at SELV and in which voltages higher than those of SELV are not generated.
17)	<b>Conductor</b> -Conductive part intended to carry electric current.
18)	<b>Conduit</b> —A part of a closed wiring system a circular or non-circular cross-section for conductors and/or cables in electrical installations, allowing them to be drawn in and/or replaced. Conduits should be sufficiently closed-jointed so that the conductors can only be drawn in and not inserted laterally.
19)	<b>Connected Load</b> — That part of the installed load of the consumer that may be supplied by the supply undertaking.
20)	<b>Connector</b> — The part of a cable coupler or of an appliance coupler which is provided with female contact and is intended to be attached to the flexible cable connected to the supply.
21)	<b>Current Carrying Capacity of a Conductor</b> — The maximum current which can be carried by a Conductor under specified conditions without its steady state temperature exceeding a specified value.
22)	<b>Danger</b> – Danger to health or danger to life or limb from shock, burn or injury from mechanical movement to persons (and livestock where present), or from fire attendant upon the use of electrical energy.
23)	<b>Dielectric</b> -A material medium in which an electric field can exist in a stationary state.
24)	<b>Direct Contact</b> – Contact of persons or livestock with live parts, which may result in electrical shock.
25)	<b>Earth</b> – The conductive mass of the earth, whose electric potential at any point is conventionally taken as zero.
26)	<b>Earth (local)</b> — Part of the Earth which is in electric contact with an earth electrode and the electric potential of which is not necessarily equal to zero.
27)	<b>Earth Conductor</b> – A protective conductor connecting the main earth terminal (or equipotential bonding conductor of an installation when there is no earth bus) to an earth electrode or to other means of earthing.
28)	<b>Earth Electrode</b> – A conductor or group of conductors in intimate contact with and providing an electrical connection to earth.
29)	<b>Earth Electrode Network</b> — Part of an earthing arrangement comprising only the earth electrodes and their interconnections.
30)	<b>Earth Electrode Resistance</b> — The resistance of an earth electrode to earth.

31)	<b>Earth Fault</b> — Occurrence of an accidental conductive path between a live conductor and the exposed conductive part or a protective conductor or earthing arrangement. NOTE — The conductive path can pass through a faulty insulation, through structures (for example, poles, scaffoldings, cranes, ladders), or through vegetation (for example trees, bushes) and can have a significant impedance.
32)	<b>Earth Fault Current</b> — A current resulting from a fault of negligible impedance between a line conductor and an exposed conductive part or a Protective conductor.
33)	<b>Earth Fault Loop Impedance</b> — The impedance of the earth fault current loop (phase to earth loop) starting and ending at the point of earth fault. This impedance is denoted by the symbol Z. The earth fault loop comprises the following, starting at the point of fault: a) the circuit protective conductor; b) the consumer's earthing terminal and earthing conductor, and for TN systems, the metallic return path; c) for TT and IT systems, the earth return path; d) the path through the earth neutral point of the transformer; e) the transformer winding; and f) the line conductor from the transformer to the point of fault.
34)	<b>Earth Fault</b> -Occurrence of an accidental conductive path between a live conductor and the earth or exposed conductive part of a protective conductor. NOTES 1 The conductive path can pass through a faulty inmlation, through structures (for example, poles scaffoldings, cranes, ladders) or through vegetation (for example, Tree, bushes) and can have a tigadicant impedance. 2 Earth fault with negligible fa impedance in solidly earthed neutral system or in a low impedance earthed neutral system are also named line-to-earth short-circuits.
35)	<b>Earth Leakage Current</b> — Current which flows to earth or to extraneous conductive parts in a circuit which is electrically sound.
36)	<b>Earthed Concentric Wiring</b> — A wiring system in which one or more insulated conductors are completely surrounded throughout their length by a conductor, for example a sheath, which acts as a PE or PEN conductor.
37)	<b>Earthing</b> — Connection of the exposed conductive parts of an installation to the main earthing terminal of that installation.
38)	<b>Earthing Arrangement</b> — All the electric connections and devices involved in the earthing of a system, an installation and equipment.
39)	<b>Earthing Conductor</b> — A protective conductor connecting the main earth terminal (or equipotential bonding conductor of an installation when there is no earth bus) to an earth electrode or to other means of earthing.
40)	<b>Earthing Resistance, Total</b> — The resistance between the main earthing terminal and the conductive mass of earth.
41)	<b>EHV (extra high voltage)</b> — A system with a nominal rms voltage is > 150 kV. NOTES 1 The above nomenclatures are adopted from IS 17036 and IS 732 for the purpose of this code. 2 Regulatory commissions of state governments use different definitions, which are not considered in this code.
42)	<b>Electric Circuit (or Circuit)</b> — An assembly of electrical equipment supplied from the same origin and protected against over current by the same protective devices
43)	<b>Electric Shock</b> — Physiological effect resulting from an electric current passing through a human or animal body.
44)	<b>ELV (extra low voltage)</b> — A system with a nominal voltage $U_n \leq 50$ V a.c. or $\leq 120$ V d.c.

45)	<b>Equipotential Bonding</b> – Electrical connections putting various exposed conductive parts and extraneous conductive parts at a substantially equal potential. Note: In a building installation, equipotential bonding conductors shall interconnect the following conductive parts: (a) Protective conductor (b) Earth continuity conductor, and (c) Risers of air-conditioning systems and heating system (if any).
46)	<b>Exposed Conductive Part</b> — A conductive part of electrical equipment, which can be touched and which is not normally live, but which may become live under fault conditions. NOTE — Typical exposed conductive parts are walls of enclosures, operating handles, etc.
47)	<b>Extraneous Conductive Part</b> – A conductive part not forming part of the electrical installation and liable to introduce a potential, generally the earth potential.
48)	<b>Fault</b> — A circuit condition in which current flows through an abnormal or unintended path. This may result from an insulation failure or a bridging of insulation. Conventionally the impedance between live conductors or between live conductors and exposed or extraneous conductive parts at the fault position is considered negligible.
49)	<b>Fault Current</b> — Current which flows across a given point of fault resulting from an insulation failure.
50)	<b>Fault Protection</b> — Protection against electric shock under single fault conditions. NOTE — For low voltage installation, systems and equipment, fault protection generally corresponds to protection against in direct contact, mainly with regards to failure of basic insulation. Indirect contact is “contact of persons or livestock with exposed- conductive parts which have become live under fault conditions.”
51)	<b>Fitting, Lighting</b> — A device for supporting or containing a lamp or lamps (for example, fluorescent or incandescent) together with any holder, shade, or reflector, for example, a bracket, a pendant with ceiling rose, or a portable unit.
52)	<b>Flashover</b> — Electrical breakdown between conductors in air, a gas or a liquid or in vacuum, at-least partly, along the surface of a solid insulation.
53)	<b>Functional Earthing</b> — Earthing a point or points in a system or in an installation or in equipment for purposes other than electrical safety.
54)	<b>HV (high voltage)</b> — A system with a nominal rms voltage is $33 < U_n \leq 150$ kV.
55)	<b>Indirect Contract</b> – Contact of persons or livestock with exposed conductive parts made live by a fault and which may result in electric shock.
56)	<b>Insulation</b> — All the materials and parts used to insulate conductive elements of a device. NOTE — See also the definitions for basic insulation, double insulation, reinforced insulation and supplementary insulation.
57)	<b>Insulation Fault</b> — in the insulation of an equipment, wire or cable which can result either in an abnormal electric current through this insulation or in a disruptive discharge.
58)	<b>Isolation</b> — Function intended to make dead for reasons of safety all or a discrete section of the electrical installation by separating the electrical installation or section from every source of electric energy.
59)	<b>Lighting Protection Zone</b> — Zone where the lightning electromagnetic environment is defined.
60)	<b>Lightning Arrester (Surge Diverter)</b> — A device which has the property of diverting to earth any electrical surges of excessively high amplitude applied to its terminals and is capable of interrupting flow of current if present and restoring itself thereafter to its original operating condition.
61)	<b>Live Part</b> – A conductor or conductive part intended to be energized in normal use, including a neutral conductor but by convention, not a PEN conductor.

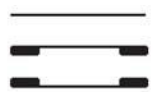
62)	<b>Luminaire</b> — Apparatus which distributes, filters or transforms the light transmitted from one or more lamps and which includes, except the lamps themselves, all the parts necessary for fixing and protecting the lamps and, where necessary, circuit auxiliaries together with the means for connecting them to the electric supply. NOTE — The term lighting fitting is deprecated.
63)	<b>LV (low voltage)</b> — A system with a nominal voltage $U_n \leq 1\,000\text{ V a.c. and } \leq 1\,500\text{ V d.c.}$
64)	<b>Main Earthing Terminal</b> — Terminal or bus bar which is part of the earthing arrangement of an installation and enabling the electric connection of a number of conductors to achieve equipotential bonding.
65)	<b>Meshed Bonding Network (MESH-BN)</b> — Bonding network in which all associated equipment frames, racks and cabinets and usually the d.c. power return conductor are bonded together as well as at multiple points to the CBN and may have the form of a mesh.
66)	<b>Miniature Circuit-breaker</b> — A compact mechanical device for making, carrying and breaking a circuit both in normal conditions and also making, carrying for a specified duration and breaking currents under specified abnormal circuit conditions such as those of short circuit.
67)	<b>Multiple Earthed Neutral System</b> — A system of earthing in which the parts of an installation, specified to be earthed are connected to the general mass of earth and, in addition, are connected within the installation to the neutral conductor of the supply system. NOTE — This definition is applicable only for voltages up to 1000 V a.c.
68)	<b>MV (medium voltage)</b> — A system with a nominal rms voltage is $1\text{ kV} < U_n \leq 33\text{ kV}$
69)	<b>Neutral or Neutral Conductor (Symbol N)</b> — A conductor connected to the neutral point of a system and capable of contributing to the transmission of electrical energy.
70)	<b>Overcurrent</b> — A current exceeding the rated value. For conductors, the rated value is the current carrying capacity.
71)	<b>Overcurrent Detection</b> — A method of establishing that the value of current in a circuit exceeds a predetermined value for a specified time.
72)	<b>Overload</b> — Operating conditions in an electrically undamaged circuit which causes an overcurrent.
73)	<b>Protective Conductor</b> — A conductor used for some measures of protection against electric shock and intended for connecting together any of the following parts: a) Exposed conductive parts; b) Extraneous conductive parts; c) The main earthing terminal; and d) The earthed point of the source, or an artificial neutral.
74)	<b>Protective Conductor</b> – A conductor used for some measures of protection against shock, and intended for connecting together any of the following parts: (a) Exposed conductive parts, (b) Extraneous conductive parts (c) The main earthing terminal, and (d) The earthed point of the source, or an artificial neutral.
75)	<b>Protective Earthing</b> — Earthing a point or points in a system or in an installation or in equipment, for purposes of electrical safety.
76)	<b>Protective Equipotential Bonding</b> — Equipotential bonding for the purpose of safety.
77)	<b>Protective Multiple Earthing (PME)</b> — An earthing arrangement, found in TN systems, in which the earthing conductor (either PEN or PE) is connected to local earthing for the purpose of reducing fault loop impedance and in case of PEN conductor, to limit potential of line conductor to earth during neutral disconnection.
78)	<b>Rated Current</b> — Value of current in accordance with which the relevant performance of a transformer operated meter is fixed.

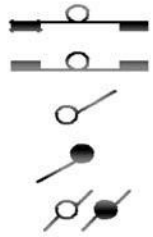
79)	<b>Relay (Electric Relay)</b> — Device designed to produce sudden predetermined changes in one or more electric output circuits, when certain conditions are fulfilled in the electric input circuits controlling the device.
80)	<b>Residual Current</b> – The algebraic sum of the instantaneous values of current flowing through all the live conductors of a circuit at a point of the electrical installation.
81)	<b>Residual Current Device (RCD)</b> – A mechanical switching device, or an association of devices intended to cause the opening of the contacts when the residual current attains a given value under the specified conditions.
82)	<b>Residual Current Operated Circuit-Breaker with Integral Overcurrent Protection (RCBO)</b> —A residual current operated switching device designed to perform the functions of protection against overload and/or short-circuit.
83)	<b>Residual Operating Current</b> – Residual current, which causes the residual current device to operate under specified conditions.
84)	<b>Surge Protective Devices (SPD)</b> — A device that is intended to limit transient overvoltage's and divert surge currents. It contains at least one non-linear component.
85)	<b>Shock Current</b> — A current passing through the body of a person or an animal and having characteristics likely to cause dangerous patho-physiological effects.
86)	<b>Short-circuit</b> — Accidental or intentional conductive path between two or more conductive parts forcing the electric potential differences between these conductive parts to be equal to or close to zero.
87)	<b>Short-Circuit Current</b> — An overcurrent resulting from a fault of negligible impedance between live conductors having a difference in potential under normal operating conditions.
88)	<b>Simultaneously Accessible Parts</b> – Conductors or conductive parts which can be touched simultaneously by a person or, where applicable, by livestock. Note: In the context of protection against direct contact, a live part may be accessible with: (a) Another live part, or (b) An exposed conductive part, or (c) An extraneous conductive part, or (d) A protective conductor
89)	<b>Spark</b> — Small luminous electric arc of short duration.
90)	<b>Standby Supply System</b> —A system intended to maintain supply to the installation or part thereof, in case of interruption of the normal supply, for reasons other than safety of persons. NOTE — Standby supplies are necessary, for example, to avoid interruption of continuous industrial processes or data processing.
91)	<b>Surge Current</b> — A transient wave appearing as an overcurrent caused by a lightning electromagnetic impulse.
92)	<b>Surge Protective Devices (SPD)</b> — A device that is intended to limit transient over voltages and divert surge currents. It contains at least one non-linear component.
93)	<b>Switch, linked</b> – A switch, the contacts of which are so arranged as to make or break all the poles simultaneously, or in a definite sequence.
94)	<b>Switchboard</b> — An assembly of switchgear with or without instruments, but the term does not apply to a group of local switches in a final circuit. NOTE — The term 'switchboard' includes a distribution board.
95)	<b>Switchgear</b> – An assembly of main and auxiliary switching apparatus for operation, regulation, protection, or other control of electrical installations. Note: For more comprehensive definitions of the terms in 2.103 to 2.106, See IS 1885 (Part 17): 1979.
96)	<b>Switchgear and Control gear</b> — A general term covering switching devices and their combination with associated control, measuring, protective and regulating equipment, also assemblies of such devices and equipment with associated interconnections,

	accessories, enclosures and supporting structures.
97)	<b>Touch Voltage</b> — Voltage between conductive parts when touched simultaneously by a person or an animal. NOTE — The value of the effective touch voltage may be appreciably influenced by the impedance of the person or the animal in electric contact with these conductive parts.
98)	<b>Transformer</b> — A static piece of apparatus with two or more windings which, by electromagnetic induction, transform a system of alternating voltage and current into another system of voltage and current usually of different value and at the same frequency for the purpose of transmitting electrical power.
99)	<b>Voltage Classifications</b> — Nomenclature of commonly used short names of voltages
100)	<b>Voltage, Potential Difference</b> — The line of integral from one point to another of an electric field, taken along a given path.
101)	<b>Wire</b> — Flexible cylindrical conductor, with or without an insulating covering, the length of which is large with respect to its cross-sectional dimensions. NOTE — The cross-section of a wire may have any shape, but the term “wire” is not generally used for ribbons or tapes.

## APPENDIX B CONVENTIONAL SIGNS & SYMBOLS FOR ELECTRICAL INSTALLATION


*[Clause 1.3.2]*


 General wiring  
 on the surface  
 Wiring under the surface


**WIRING IN CONDUIT**  

**WIRING IN CONDUIT**  
 Conduit on surface  
 Concealed conduit wiring  
 going upwards wiring  
 going downwards  
 Wiring passing vertically

### FUSE BOARDS

#### LIGHTING CIRCUIT FUSE-BOARDS

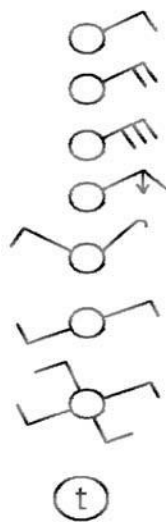

 Main fuse-board without switches  
 Main fuse-board with switches  
 Distribution fuse-board without switches  
 Distribution fuse-board with switches

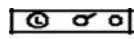





























#### POWER CIRCUIT FUSE-BOARDS


 Main fuse-board without switches  
 Main fuse-board with switches  
 Distribution fuse-board without switches  
 Distribution fuse-board with switches

### SWITCHES & SWITCH OUTLETS

#### ONE WAY SWITCH


 Singlepole  
 Two poles  
 Threepoles  
 Single pole pull switch  
 Multi-position switch (for different degrees of lighting)  
 Two-way switch  
 Intermediate switch  
 Period limiting switch  
 Timeswitch

	Pendant Switch
	Pushbutton
	Luminous push button
	Restricted access push button
<b>SOCKET OUTLETS</b>	
	Socket-outlet, 5A
	Socket-outlet, 15A
	Combined switch & socket-outlet, 5A
	Combined switch & socket-outlet, 15A
	Interlocking switch & socket-outlet, 5A
	Interlocking switch & socket-outlet, 15A
<b>LAMPS AND LIGHTING APPARATUS</b>	
	Lamp or outlet for lamp
	Group of three 40 W lamps
	Lamp mounted on a wall
	Lamp mounted on a ceiling
	Counter-weight lamp fixture
	Chain lamp fixture
	Road lamp fixture
	Lamp fixture with built-in-switch
	Lamp fed from variable voltage supply
	Emergency lamp
	Panic lamp
	Bulk head lamp
	Water-tight lighting fitting
	Batten lamp holder
	Projector
	Spot light
	Flood light
	Fluorescent lamp
	Group of three 40 W fluorescent lamps
<b>ELECTRICAL APPLIANCES</b>	
	General

### **BELLS, BUZZERS**



Bell push



Bell



Buzzer

### **FIRE ALARM**



Fire alarm push



Automatic contact



Bell connected to fire alarm

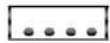


Fire alarm indicator  
(At 'N' insert number of ways)

### **PUBLIC ADDRESS SYSTEM**



Amplifier



Control board



Microphone outlet



Loudspeaker outlet

### **RADIO RECEPTION OUTLETS**



Receiver outlet

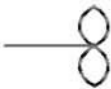


Aerial

### **FIXED APPARATUS OUTLETS**



Ceiling fan



Bracket fan

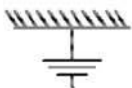


Exhaust fan

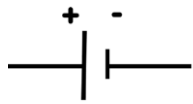


Fan regulator

### **EARTHING**



Earth point



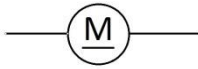
Cell



Voltmeter



Ammeter



Motor



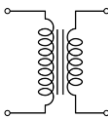
Diode



Variable Resistance



LED



Transformer



Generator



Capacitor



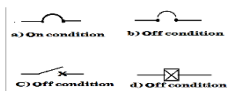
Inductor



Resistance



AC Voltage Source



Circuit Breaker

## APPENDIX C

### IMPORTANT CLAUSES OF CENTRAL ELECTRICITY AUTHORITY (MEASURES RELATING TO SAFETY AND ELECTRIC SUPPLY) REGULATIONS 2023, AND RELATED CLAUSES AMENDED UP TO DATE

[Clause 1.21]

The following clauses of Central Electricity Authority (Measures relating to Safety and Electric Supply) Regulations 2023 and related clauses amended up to date shall in particular be taken care of in the execution of Internal EI works, besides other applicable clauses: -

<i>S No</i>	<i>Clause No.</i>	<i>Subject</i>
1	3	Designating person(s) to operate and carry out the work on electrical lines and apparatus.
2	5	Electrical Safety Officer
3	7	Safety measures for operation and maintenance of transmission, distribution systems.
4	14	General safety requirements. pertaining to construction, installation, protection, operation, and maintenance of electric supply lines and apparatus.
5	15	Service lines and apparatus on consumer's premises
6	16	Switchgear on consumer's premises
7	17	Identification of earthed and earthed neutral conductors and position of switches and switchgear therein
8	18	Earthed terminal on consumer's premises
9	19	Accessibility of bare conductors
10	20	Danger Notices
11	21	Handling of electric supply lines and apparatus
12	26	Distinction of different circuits
13	28	Accidental charging
14	29	Provisions applicable to protective equipment
15	30	Display of instructions for resuscitation of persons suffering from electric shock
16	31	Precautions to be adopted by consumers, owners, occupiers, electrical contractors, electrical workmen and suppliers
17	32	Periodical inspection and testing of Installations
18	33	Testing of consumer's installation
19	35	Precautions against leakage before connection
20	36	Leakage on consumer's premises
21	37	Supply and use of electricity
22	38	Provisions for supply and use of electricity in multi-storeyed building more than 15 metres in height

23	39	Conditions applicable to installations of voltage, exceeding 250 Volts
24	41	Precautions against failure of supply and notice of failures
25	42	Test for resistance of Insulation
26	43	Connection with earth
27	44	Residual current device
28	45	Approval by the electrical inspector & self certification
29	46	Use of electricity at voltage exceeding 650 Volts
30	47	Inter locks & Protection for use of electricity at voltage exceeding 650 V
31	48	Testing, operation & maintenance
32	49	Precautions to be taken against excess leakage in case of metal sheathed electric supply lines.
33	50	Connection with earth for apparatus exceeding 650 V
34	51	General conditions for transformation and control of electricity.
35	Chapter XI	Safety Provisions for Electric Vehicle Charging Stations

**APPENDIX- D**  
**IMPORTANT INDIAN STANDARDS**  
*[Clause 1.22.4]*  
**CODES OF PRACTICE GUIDE**

Sl. No.	Standard	Title	Reaffirm Year	Amdt.
(1)	IS 732:2019	Code of practice for electrical wiring installations (fourth revision)	2019	
(2)	IS 4648:1968 (R 2017)	Guide for electrical layout in residential buildings	2012 (R2017)	
(3)	IS 8061:1976 (R 2016)	Code of practice for design, installation and maintenance of service lines upto and including 650 V	2011 (R 2016)	
(4)	IS 8884:1978 (R 2002)	Code of practice for the installation of electric bells and call systems	2012 (R 2002)	
(5)	IS 5578:1984/ IEC 60391(1972)	Guide for marking of insulated conductors (first revision)	2011	
(6)	IS 11353:1985/ IEC 60445 (1973)	Guide for uniform system of marking and identification of conductors and apparatus terminals	2017	
(7)	IS 13234:1991/ IEC 60909: 1988	Guide for short circuit current calculations in three-phase ac systems (superseding IS 5728)	2017	
(8)	IS 7752 (Part 1): 1975	Guide for improvement of power factor in consumer installation: Part 1 Low and medium supply voltages	2016	
(9)	IS 3646 (Part 1): 1992	Code of practice for interior illumination: Part 1 General requirements and recommendations for working interiors (first revision)	2018	
(10)	IS 3646 (Part 2): 1966	Code of practice for interior illumination: Part 2 Schedule of illumination and Glare index	2018	
(11)	IS 3646 (Part 3): 1968	Code of practice for interior illumination: Part3Calculation of coefficients of utilization by the BZ method	2018	
(12)	IS 4347:1967	Code of practice for Hospital Lighting	2020	
(13)	IS 6665:1972	Code of practice for industrial lighting	2020	
(14)	IS 2672:1966	Code of practice for library lighting	2020	
(15)	IS 10118 (Part 1):1982	Code of practice for selection, installation and maintenance of switchgear and control gear : Part 1 General	2018	
(16)	IS 10118 (Part 2):1982	Code of practice for selection, installation and maintenance of Switchgear and control	2016	

		gear : Part 2 Selection		
(17)	IS 10118 (Part 3):1982	Code of practice for selection, installation and maintenance of switchgear and control gear : Part 3 Installation	2016	
(18)	IS 10118 (Part 4):1982	Code of practice for selection, installation and maintenance of switchgear and control gear : Part 4 Maintenance	2016	
(19)	IS 4146:1983	Application guide for voltage transformers (first revision)	2016	
(20)	IS 4201:1983	Application guide for current transformers (first revision)	2016	
(21)	IS 5547:1983	Application guide for capacitor voltage transformers (first revision)	2016	
(22)	IS 2309:1989	Code of practice for protection of buildings and allied structures against lightning (second revision)	2010	1
(23)	IS 3043:1987	Code of practice for earthing (Second Revision)	2018	2
(24)	IS 5216 (Part 1):1982	Recommendations on safety procedures and practices in electrical work: Part 1 General	2020	
(25)	IS 5216 (Part 2):1982	Recommendations on safety procedures and practices in electrical work: Part 2 Life saving techniques	2020	
<b>ELECTRIC FANS CODES OF PRACTICE GUIDE</b>				
<b>Sl. No.</b>	<b>Standard</b>	<b>Title</b>	<b>Reaffirm Year</b>	<b>Amdt.</b>
(1)	IS 555:1979	Electric table type fans regulators	2020	2
(2)	IS 1169:1967	Electric pedestal type fans and regulators	2019	6
(3)	IS 374:1979	Electric ceiling type fans (fourth revision)	2019	6
(4)	IS 2997:1964	Air circulator type electric fans and regulators	2019	8
(5)	IEC: 60665 (1981) IS 2312:1967	Propeller type ac ventilating fans	2010	8
(6)	IS 3588:1987	Electric axial flow fans	2009	1
(7)	IS 3963:1987	Roof Extractor units	2009	3
(8)	IS 4283:1981	Hot Air Fans	2009	3
(9)	IS 6272:1987	Industrial Cooling Fans (man Coolers)	2009	2
(10)	IS 4894:1987	Centrifugal Fans	2009	3

(12)	IS 12155:1987	General and safety Requirements for Fans and Regulators for Household and similar purposes	1999	
<b>LOW VOLTAGE SWITCH GEAR AND CONTROL GEAR CODES OF PRACTICE GUIDE</b>				
Sl.No.	Standard	Title	Reaffirm Date	Amdt.
1)	IS 4237:1982	General requirements for switchgear and control gear for voltages not exceeding 1000 volts ac or 1200 volts dc		
2)	IS 6875 (Part 1): 1973	Control switches (switching devices for control and auxiliary circuits including contactor relays) for voltages up to and including 1000Vac & 1200Vdc: Part 1 General requirements [superseded by IS 13947 (Part 5/Section 1)]	1992	
3)	IS 6875 (Part 2): 1973	Control switches (switching devices for control and auxiliary circuits including contactor relays) for voltages up to and including 1000Vac and 1200Vdc: Part 2 Push-buttons and related control switches [Superseded by IS 13947 (Part 5/Section 1)]	1992	
4)	IS 6875 (Part 3): 1980	Control switches (switching devices for control and auxiliary circuits including contactor relays) for voltages up to and including 1000 V ac and 1200 V dc : Part 3 Rotary control switches [superseded by IS 13947 (Part 5/ Section 1)]	1992	
5)	IS 10027:2000	Composite units of Air-Break switches and Rewireable Type Fuses for voltages Not Exceeding 650voltac-Specification (Second revision)	2018	
6)	IS 4064 (Part 1): 1978	Air-break switches, air break disconnectors, air-break switch disconnectors and fuse-combination units for voltages not exceeding 1000 V ac or 1200 V dc: Part 1 General requirements (revised) [superseded by IS 13947 (Part 3): 1993]		
7)	IS 2675:1983	Enclosed Distribution Fuse Boards and Cut Outs for voltages Not Exceeding 1000 V A.C. or 1200 V D.C.	2016	
8)	IS 8828:1996	Electrical Accessories Circuit-breakers for over current protection for household and similar installations (second revision)	2006	
9)	IS 13032:1991	AC Miniature Circuit Breaker Boards for voltage Not Exceeding 1000 Volt	2016	1
10)	IS 12640 (Part 1): 2008	Residual Current operated Circuit Breaker without integral over current Protection for	2016	

		Household and similar uses (RCCBs) Part 1 General Rules (Second Revision)		
11)	IS 12640 (Part 2): 2008	Residual Current Operated Circuit-Breakers with integral over current Protection for Household and similar Uses Part 2 General Rules (Second Revision)	2016	
12)	IS 2959:1985	Contactors for voltages not exceeding 1000 V ac or 1200 V dc		
13)	IS 12021:1987	Control transformers for switchgear for voltages not exceeding 1000 Volt AC specifications (first Revision)	2015	2
14)	IS 5039:1983	Distribution pillars for voltages not exceeding 1000 volts AC and 1200 VDC	2021	2
15)	IS 8623 (Part 1): 1993/ IEC 60439-1 (1985)	Low voltage Switchgear and control gear assemblies: Part 1 Requirements for type- tested and partially type tested assemblies. (Suspended IS/IEC 61439-2:2011)	2013	0
16)	IS 8623 (Part 2):1993/ IEC 60439-2 (1987)	Low voltage switchgear and control gear assemblies: Part 2 Particular requirements for Busbar trunking systems (Busway)	2018	1
17)	IS 8544 (Part 1): 1977	Motor starters for voltages not exceeding 1000 V: Part Direction line ac starters [superseded by IS 13947 (Part 4/Section 1): 1993]		2
18)	IS 8544 (Part 2): 1977	Motor starters for voltages not exceeding 1000 V : Part 2 Star-delta starters [superseded by IS 13947 (Part 4/ Section 1): 1993]		
19)	IS 8544 (Part 3/ Sec 1): 1979	Motor starters for voltages not exceeding 1000 V : Part 3 Rheostatic motor starters, Section 1 General requi rements [superseded by IS 13947 (Part 4/Section 1):1993]		
20)	IS 8544 (Part 4): 1979	Motor starters for voltages not exceeding 1000 V: Part 4 Reduced voltage ac starters: two step auto-transformer starters [superseded by IS 13947 (Part 4/Section 1): 1993]		
<b>POWER CABLE CODES OF PRACTICE GUIDE</b>				
<b>Sl.No.</b>	<b>Standard</b>	<b>Title</b>	<b>Reaffirm Date</b>	<b>Amdt.</b>
1)	IS 694:1990/ IEC 60227- 1 to 5 (1979)	PVC Insulated cables for working voltages up to and including 1100 V	2010	0
2)	IS 694: 2010	Polyvinyl chloride insulated sheathed and unsheathed cables with rigid and flexible conductor for rated voltages upto and including : Part 1 General requirements (fourth revision)	2020	

3)	IS 1554 (Part 1): 1988/ IEC 60502 (1983)	PVC insulated (heavy duty) electric cables: Part For working voltages including 110 V	2020	5
4)	IS 3961 (Part 1): 1967	Recommended current ratings for cables: Part 1 Paper insulated lead sheathed cables	2016	
5)	IS 4288:1988	PVC insulated (heavy duty) electric cables with solid aluminium conductors for voltages up to and including 1100 V (second revision) (withdrawn)		
6)	IS 4289 (Part 1): 1984/ IEC 60245-5	Flexible cables for lifts and other flexible connections: Part 1 Elastomer insulated cables (first revision)		
<b>ELECTRIC WIRING ACCESSORIES</b>				
Sl.No.	Standard	Title	Reaffirm Date	Amdt.
1)	IS 9537 (Part 1): 1980/ IEC 60614-1 (1978)	Conduits for electrical installations: Part 1 General Requirements	2020	(1)
2)	IS 9537 (Part 2): 1981 documents 23 and 23A (Central Office) 29 Draft	Conduits for electrical installations: Part 2 Rigid steel conduits (superseding IS:1653)	2017	(2)
3)	IS 3480:1966 B.S. 731 : Part-I : 1952 UL 1-1957	Flexible steel conduits for electrical wiring	2017	(1)
4)	IS 3837:1976	Accessories for rigid steel conduits for electrical wiring (first revision)	2017	(1)
5)	IS 9537 (Part 4):1983 Documents 23A (Central Office) 23 and 23A (Central Office)	Conduits for electrical installations: Part 4 Pliable self- recovering conduits of insulating materials	2017	
6)	IS 3419:1988 BS 4607 (Part-1) : 1984	Fittings for rigid non-metallic conduits (Second Revision)	2017	
7)	IS 2412:1975	Specification for Link clips for electrical wiring First Revision	2017	(2)
8)	IS 371:1999	Ceiling roses –Specification Third Revision	2020	(4)
9)	IS 4160:2005/ IEC 60884-2-6 (1997)	Interlocking switch socket outlets – Specification	2020	
10)	IS 1293:2019/ IEC 60884-1 (2002)	Plugs and Socket-Outlets for Household and Similar Purposes of Rated Voltage up to and Including 250 V and Rated Current up to and Including 16 A — Specification (Fourth Revision)	2010	(1)

11)	IS B371:1999	Ceiling roses Specification	2020	
12)	IS 4160 : 2005 IEC Publication 60884-2-6 (1997)	Interlocking switch socket outlets – Specification First Revision		
13)	IS 4649 : 1968	Specification for adaptors for flexible steel conduits		
14)	IS 9537 (Part 3) : 1983 IEC Publication 614- 2 (1980)	Specification for conduits for electrical installations Part 3 rigid plain conduits of insulating materials		
15)	IS 9537 (Part 8) : 2003 IEC Publication 60614-2-7 (1995) 2018	Conduits for electrical installation – Specification Part 8 rigid non-Threadbare conduits of aluminum alloy		
16)	IS 10276 (Part 1) :1982 a) b) c) Electro technical Commission 238 (1975) Edison screw lamp holders. IEC P	Specification for Edison screw lamp holders Part 1 requirements and tests		
17)	IS 10276 (Part 2) :1982 IEC Publication 61 (1969)	Specification for Edison screw lamp holders Part 2 standard data sheets for lamp holders and gauges		
18)	IS 14763: 2022	Conduit Systems for Cable Management Outside Diameters of Conduits for Electrical Installations and Threads for Conduits and Fitting		
19)	IS 14768 (Part 2) :2003 IEC Publication 61035-24 (1993)	Conduit fittings for electrical installations - Specification Part 2 metal conduit fittings		
20)	IS 14927 (Part 1): 2001 ISO 9226	Cable trunking and ducting systems for electrical installations Part 1 general requirements		
21)	IS 14927 (Part 2): 2001	Cable Trunking and Ducting Systems for Electrical Installations Part 2 Cable Trunking and Ducting Systems Intended for Mounting on Walls or Ceiling		
22)	IS 14930 (Part 7): 2001	Conduit Systems for Electrical Installations - Part 2 Particular Requirements - Conduit Systems Burred Underground		
23)	IS 15368: 2003 IEC 61242 (1995)	Cable reels for household and similar purposes		

24)	IS 15787: 2008 IEC Publication 60884-2-3	Switch - Socket - Outlets Non - Interlock Type		
25)	IS 16205 (Part 1): 2017 ice 61386-1	Conduit systems for cable management Part I general requirements		
26)	IS 16205 (Part 21): 2017	Conduit Systems for Cable Management Part 21 Particular Requirements Rigid Conduit Systems		
27)	IS 16205 (Part 22): 2017	Conduit Systems for Cable Management Part 22 Particular Requirements - Pilable Conduit Systems		
28)	IS 16205 (Part 23): 2017	Conduit Systems for Cable Management Part 23 Particular Requirements Flexible Conduit Systems		
29)	IS 16205 (Part 24): 2017	Conduit Systems for Cable Management part 24 Particular Requirements Conduit Systems Buried Under Ground		
30)	IS 16783: 2018	Cable Cleats for Electrical Installations		
31)	IS 17039: 2018 IEC 61316: 1999 IEC 61316: 1999	Industrial Cable Reels		
32)	IS 17345 (Part 1): 2020 LEC 61534-1	Power Track System Part 1 General Requirement		
33)	IS 17345 (Part 21): 2020 IEC 61534-21	Power Track System Part 21 Particular Requirements for Power Track Systems Intended for Wall and Ceiling Mounting		
34)	IS/TEC 60309-1: 2002 IEC 60309-1 (1999) IEC 60309-1 (1999)	Plugs socket - Outlets and couplers for industrial purposes Part 1 general requirements First Revision		
35)	IS/TEC 60320-2-2): 1998 IEC 60320-2-2:1998	Appliance couplers for household and similar general purposes Part 2 Sec 2 interconnection couplers for household and similar equipment		
36)	IS/IEC 60320-2-3): 1998 IEC 60320-2-3:1998	Appliance couplers for household and similar general purposes Part 2 - 3 appliance couplers with a degree of protection higher than ipxo		
37)	IS/IEC 60669-2-2): 2006 IEC 60669-2-2: 2008	Switches for Household and Similar Fixed Electrical Installations Part 2 Particular Requirements Section 2 Electromagnetic remote-control switches <u>RCS</u>		
38)	IS/IEC 60669-2- 1): 2008 60669-2-1	Switches for Household and Similar Fixed Electrical Installations Part 2 Particular Requirements Section 1 Electronic Switches		

39)	IS/TEC 60884-2- 5): 1995 IEC 60884-2-5: 1995	Plugs and Socket-Outlets for Household and Similar Purposes Part 2 Particular Requirements DSection 5 Adaptors		
40)	IS/IEC 60998-I: 2002	Connecting Devices for Low-Voltage Circuits for Household and Similar Purposes Part 1 General Requirements		
41)	IS/IEC 61058 -1 :2000 IEC 61058 – 1: 2000	Switches for appliances Part 1 general requirements		
42)	IS/IEC 61537: 2006 IEC 61537: 2006 IEC 61537: 2006	Cable Management – Cable Tray System and Cable Ladder System		
43)	IS/IEC 62275: 2018	Cable Management Systems – Cable ties for electrical installations		
<b>ELECTRICAL LAMPS AND THEIR AUXILIARIES</b>				
Sl.No.	Standard	Title	Reaffirm Date	Amdt.
1)	IS 418:2004/ IEC 60064 (1993)	Tungsten filament lamps for domestic and similar general lighting purposes	2019	5
2)	IS 2418 (Part 1): 2018/ IEC 81 (1974)	Tubular fluorescent lamps for general lighting service: Part 1 Requirements and tests (Second revision)	2018	(1)
3)	IS 9900 (Part 1): 1981 / IEC 188 (1974)	Highpressuremercuryvapourlamps:Part1Req uirements and test [Superseding IS 2183 and IS 7023]	2017	(4)
4)	IS 9974 (Part 1): 1981/ IEC 662 (1980)	High pressure sodium vapour lamps : Part 1 General requirements and tests	2017	(1)
5)	IS 1258:2005/ IEC 61184 (1997)	Bayonet lamp holders Fourth Revision	2020	(4)
6)	IS 3324:1982/ IEC Pub 400 (1972)	Holders for starters for tubular fluorescent lampsFirst Revision	2018	
7)	IS 2215:2006/ IEC 60155(1993)	Starters for fluorescent lamps	2020	
8)	IS 1534 (Part 1): 1977 / IEC 82 (1973)	Ballasts for fluorescent lamps: Part 1 For switch start circuits	2011	(5)
9)	IS 1569:1976/ IEC 566	Capacitors for use in tubular fluorescent high-pressure mercury and low-pressure sodium vapour discharge lamp circuit	2016	(1)
10)	IS 6616:1982/ IEC 262 (1969)	Ballasts for high pressure mercury vapour Lamps	2011	(1)
<b>LIGHT FITTINGS AND LUMINAIRES</b>				
Sl.No.	Standard	Title	Reaffirm Date	Amdt.
1)	IS 1913 (Part 1): 1978	General and safety requirements for luminaires: Part 1 Tubular fluorescent lamps		

2)	*IS 10322 (Part 1) :1982 / IEC 598 - 1(1979)	Luminaires: Part 1 General requirements	2020	
3)	IS 10322 (Part 2): 1982 / IEC 598 - 1(1979)	Luminaires: Part 2 Constructional Requirements	2010	
4)	IS 10322 (Part 5/ Sec. 2):2012	Luminaires: Part 5 Particular requirements, Sec 2 Recessed luminaires (First Revision)	2012	
5)	IS 10322 (Part 5/ Sec. 3):2012/ IEC 60598-2-3 (1979)	Luminaires: Part 5 Particular requirements, Sec 3 Luminaires for road and street lighting (First revision)	2012	
6)	IS 10322(Part 5/ Sec 4):1987/ IEC60598-2-4 (1979)	Luminaires: Part 5 Particular requirements, Section 4 Portable general purpose	2010	1
7)	IS 10322(Part 5/ Sec 5):1987/ IEC60598-2-5	Luminaires: Part 5 Particular requirements, Section 5 Flood lights [superseding IS 1947]	2010	(1)
8)	IS 3287:1965	Industrial lighting fittings with plastic reflectors	2005	
9)	IS 1777:1978	Industrial luminaires with metal reflectors		
10)	IS 2206 (Part 1): 1984	Flameproof electric lighting fittings: Part 1 Well-glass and bulkhead types	2005	
11)	IS 3528:1966	Waterproof electric lighting fittings	2015	
12)	IS 3553:1966	Watertight electric lighting fittings	2015	
13)	IS 8030:1976/ IEC 162 (1972)	Luminaires for hospitals	2013	
14)	IS 7537:1974	Road traffic signals	2018	
15)	IS 9583:1981/ IEC 598-2-22 (1980)	Emergency lighting units	2018	
<b>ELECTRICAL APPLIANCES</b>				
Sl. No.	Standard	Title	Reaffirm Date	Amdt.
1)	IS 302 (Part 1): 2008/ IEC 60335-1 (2006)	Safety of household and similar electrical appliances: Part 1 General requirements	2016	(4)
2)	IS 2268:1994	Electric call bells and buzzers for indoor use	2019	
3)	IS 3412:1994	Electric water boilers	2016	

ELECTRICAL INSTRUMENTS				
Sl. No.	Standard	Title	Reaffirm Date	Amdt.
1)	IS 6236:2020/ IEC 60258(1968)	Direct recording electrical measuring Instruments and Their Accessories (First Revision)		
2)	IS 1248(Part 1): 2021/ IEC 600 51-1 (1997)	Direct acting indicating analogue electrical measuring instruments and their accessories: Part 1 Definitions and general requirements common to all parts Fifth Revision		
3)	IS 1248(Part 2): 2021/ IEC 600 51-2 (1984)	Direct acting indicating analogue electrical measuring instruments and their accessories: Part 2 Special requirements for ammeters and voltmeters		
4)	IS 1248(Part 3): 2021/ IEC 600 51-3 (1984)	Direct acting indicating analogue electrical measuring instruments and their accessories: Part3Special requirements for Watt meters and varmeters		
5)	IS 1248(Part 4): 2003/ IEC 600 51-4 (1984)	Direct acting indicating analogue electrical measuring instruments and their accessories: Part 4 Frequency meters	2018	1
6)	IS 1248 (Part 5): 2021/ IEC 600 51-5 (1984)	Direct acting indicating analogue electrical measuring instruments and their accessories: Part 5 Special requirements for Phase meters, power factor meters and synchroscope		
7)	IS 722(Part 1): 1998	AC electricity meters : General requirement and tests	1991	
8)	IS 722 (Part 2): 1977	AC electricity meters: Part 2 Single-phase whole-current watt-hour meters, Class 2	1991	
9)	IS 722 (Part 3): 1988	AC electricity meters: Part 3 Three-phase whole current and transformer operated and single-phase transformer operated watt-hour meters, class 2 <b>Super seeded by : IS 13010, IS 13779</b>	1991	
10)	IS 722 (Part 5): 1980	AC electricity meters: Part 5 Volt-ampere hour meters for restricted power factor range, class 3.5 <b>Super seeded by : IS 14415</b>		
11)	IS 722 (Part 7/Sec 1): 1987	AC electricity meters: Part 7 Volt-ampere hour meters for full power factor range, Section 1 General requirements <b>Super seeded by : IS 14372</b>		
12)	IS 722 (Part 8): 1972	AC electricity meters: Part 8 Single-phase 2-wire whole current watt-hour meter (class 1.0) <b>Super seeded by : IS 13010, IS 13779</b>	1991	
13)	IS 722 (Part 9): 1972	AC electricity meters: Part 9 Three-phase whole current and transformer operated watt-hour meters and single- phase two-wire transformer operated watt-hour meters (class	1991	

		1.0) <b>Super seeded by</b> : IS 13010, IS 13779		
14)	IS 8530: 1977 IEC 60211:1966	Maximum demand indicators (class 1)	2010	
15)	*IS 2992:1987	Insulation resistance testers, hand operated (magneto generator type)	2015	
16)	IS 3010 (Part 1) :1965 IEC Doc :23 (Secretariat) 58	Specification for appliance – connectors and appliance –Inlets Non- Reversible Three-Pin Type Part-1 appliance-connectors		
17)	IS 3010 (Part 2) :1965 IEC Doc :23 (Secretariat) 58	Specification for appliance – connectors and appliance –Inlets Non- Reversible Three-Pin Type Part-2 appliance-Inlets		
<b>INSTRUMENT TRANSFORMERS</b>				
<b>Sl. No.</b>	<b>Standard</b>	<b>Title</b>	<b>Reaffirm Date</b>	<b>Amdt.</b>
1)	IS 2705 (Part 1): 1992/ IEC 60185 (1966)	Current transformers: General Requirements		
2)	IS 2705 (Part 2): 1992/ IEC 60185 (1966)	Current transformers: Part 2 Measuring current transformers <b>Superseeded by</b> : IS 16227 (Part 2) : 2016/IEC 61869-2 : 2012	2017	
3)	IS 2705 (Part 3): 1992/ IEC 60185 (1966)	Current transformers: Part 3 Protective current transformers	2012	
4)	IS 2705 (Part 4): 1992/ IEC 60185 (1966)	Current transformers: Part 4 Protective current transformers for special purpose applications	2012	
5)	IS 6949:1973	Summation current transformers	2016	
<b>FUSES</b>				
<b>Sl. No.</b>	<b>Standard</b>	<b>Title</b>	<b>Reaffirm Date</b>	<b>Amdt.</b>
1)	IS 9224 (Part 1): 1979	Low voltage fuses: Part 1 General requirements [superseded by IS 13703 (Part 1)]		
2)	IS 9224 (Part 2): 1979	Low voltage fuses: Part 2 Supplementary requirements for fuses for industrial applications (superseding IS2208) [superseded by IS 13703 (part 2/Section1)]		
3)	IS 2086:1993	Carriers and bases used in rewirable type electric fuses for voltages upto 650 V	2019	(1)
4)	IS 9926:1981	Fuse wires used in rewirable type electric fuses upto 650 volts	2021	
5)	IS 8187:1976/ IEC 269-3 (1973)	D-type fuses <b>Superseeded by</b> : IS/IEC 60269-3 : 2010	2016	

<b>MISCELLANEOUS</b>				
<b>Sl. No.</b>	<b>Standard</b>	<b>Title</b>	<b>Reaffirm Date</b>	<b>Amdt.</b>
1)	IS 2551:1982	Danger notice plates	2020	
2)	IS 2448 (Part 1): 1963	Adhesive insulating tapes for electrical purposes: Part 1 Tapes with cotton textile substrates	2020	(5)
<b>ELECTROTECHNICAL VOCABULARY</b>				
<b>Sl. No.</b>	<b>Standard</b>	<b>Title</b>	<b>Reaffirm Date</b>	<b>Amdt.</b>
1)	IS 1885 (Part 1): 1961	Electrotechnical vocabulary: Part 1 Fundamental Definitions	2017	(2)
2)	IS 1885 (Part 9): 2019/ IEC60050 (446):1983	Electrotechnical Vocabulary: Part 9 Electrical relays (Third revision)		
3)	IS 1885 (Part 11): 1966	Electrotechnical vocabulary: Part 11 Electrical Measurements <b>Superseded by : Completely Withdrawn</b>	2017	
4)	IS 1885 (Part 16/ Sec 1):1968	Electrotechnical vocabulary: Part 16 Lighting, Section 1 General aspects	2017	
5)	IS 1885 (Part 16/ Sec. 2):1968	Electrotechnical vocabulary: Part 16 Lighting, Section 2 General illumination, lighting fittings and lighting for traffic and signaling	2017	
6)	IS 1885 (Part 16/ Sec. 3):1967	Electrotechnical vocabulary: Part 16 Lighting, Section 3 Lamps and auxiliary apparatus	2017	
7)	IS 1885 (Part 17): 1979	Electrotechnical vocabulary: Part 17 Switchgear and control gear	2017	
8)	IS 1885 (Part 32):2019/ IEC 60050 (461): 1984	Electrotechnical Vocabulary: Part 32 Electric cables (Second revision)		
<b>SAFETY</b>				
<b>Sl. No.</b>	<b>Standard</b>	<b>Title</b>	<b>Reaffirm Date</b>	<b>Amdt.</b>
1)	IS 4770:1991	Rubber Gloves for electrical purposes	2017	1
2)	IS 5424:1969	Rubber mats for electrical purpose (Superseded by IS 15652:2006)	2004	
<b>NATIONAL ELECTRIC CODES</b>				
<b>Sl. No.</b>	<b>Standard</b>	<b>Title</b>	<b>Reaffirm Date</b>	<b>Amdt.</b>
1)	NEC 2023	National Electric Code, 2023	2023	



- II. Earthing
  - (i) Description of earthing electrode.
  - (ii) No. of earth electrodes.
  - (iii) Size of main earth lead.
- III. Test results:
  - (a) Insulation resistance
    - (i) Insulation resistance of the whole system of  
Conductors to earth –  
Megaohms
    - (ii) Insulation between the phase conductor and neutral  
Between Phase R and neutral – Mega  
ohms Between Phase Y and neutral – Mega  
ohms Between Phase B and neutral –  
Megaohms
    - (iii) Insulation resistance between the phase conductors in case of polyphase  
supply.  
Between Phase R and Phase Y – Mega ohms  
Between Phase Y and Phase B – Mega ohms  
Between Phase B and Phase R – Mega ohms
  - (b) Polarity test  
Polarity of linked single pole branch switches.
  - (c) Earth continuity test  
Maximum resistance between any point in the earth continuity conductor including  
metal conduits and main earthing lead ..... Ohms
  - (d) Earth electrode resistance  
Resistance of each earth  
electrode
    - (i) Ohms
    - (ii) Ohms
    - (iii) Ohms
    - (iv) Ohms
  - (e) Lighting protective system  
Resistance of the whole of lightning protective system to earth before any bonding is  
effected with earth electrode and metal in/on the structure ..... Ohms.

Signature and name of  
the Junior Engineer (E) /AE (E)

Signature and Name of  
Contractor

## **APPENDIX F EARTHING**

### **F.1 General**

This appendix covers general requirements associated with earthing in electrical installations. It is based on the following standards

- (i) IS 3043:2018 Code of Practice of Earthing
- (ii) IS732:2019 Code of Practice for Electrical Wiring Installations
- (iii) IEC 61936-1: Power installations exceeding 1 kV a.c. – Part 1: Common rules
- (iv) ISO/IEC 30129: Information technology – Telecommunications bonding networks for buildings and other structures

### **F.2 Basic Purpose of Earthing**

#### **F.2.2 Earth Fault Protection for Safety**

- 1) The occurrence of an earth fault in an installation creates two possible hazards:
  - (a) Firstly, voltages appear between exposed conductive parts and extraneous conductive parts, and if these parts are simultaneously accessible, these voltages constitute a shock hazard, this condition being known as indirect contact.
  - (b) Secondly, the fault current that flows in the phase and protective conductors of the circuit feeding the faulty equipment may be of such a magnitude as to cause an excessive temperature rise in those conductors, thereby creating a fire hazard.
- 2) The protective measure known as protective equipotential bonding and automatic disconnection of the supply is intended to give a high degree of protection against both hazards. The choice of protective device used to give disconnection is influenced by the type of system of which the installation is part, because either:
  - (a) the earth fault loop impedance has to be low enough to allow adequate earth fault current flow to cause an overcurrent protective device (for example, a fuse or circuit breaker) in the faulty circuit to operate in a sufficiently short time; or
  - (b) Where it is not possible to achieve a low enough earth fault loop impedance, disconnection may be initiated by fitting a residual current device (RCD) of 30 mA rating.

#### **F.2.2 Earthing for Functionality of Electronics and ICT systems**

**F.2.2.1** Some electronic equipment requires a reference voltage at about earth potential in order to function correctly; this reference voltage is provided by the functional earthing conductor. Conductors for functional earthing may be metallic strips, flat braids and cables with circular cross section. For equipment operating at high frequencies, metallic strips or flat braids are preferred and the connections shall be kept as short as possible.

**F.2.2.2** Cream colour is specified for functional earthing conductors. The colours green and yellow specified for protective conductors shall not be used. It is recommended that the same colour is used throughout the whole installation to mark functional earthing conductors at each end.

### **F.3 General Requirement**

1. The subject of earthing covers the problems associated with connection of exposed conductive part of installations to the main earthing terminal of that installation and achieving automatic disconnection of supply before the fault voltage creates a shock hazard. The terms earth and earthing have been used in this appendix, irrespective of reliance being placed on the earth itself, to denote a low impedance return path of the fault current. As a matter of fact, the earth now rarely serves as a part of the return circuit but is being used mainly for fixing the voltage of system neutrals.
2. Earthing shall generally be carried out in accordance with the requirements of Central Electricity Authority (Measures relating to Safety and Electric Supply) Regulations, 2010 as

amended from time to time.

3. In cases where direct earthing may prove harmful rather than provide safety (for example, high frequency and mains frequency coreless induction furnaces), relaxation may be obtained from the competent authority.
4. All connections shall be carefully made. If they are poorly made or inadequate for the purpose for which they are intended, loss of life or serious personal injury may result. It is recommended that the value of any earth fault loop impedance shall be such as to conform to the degree of shock protection desired.
5. It is recommended that a drawing showing the earthing system be prepared for each installation.
6. No addition to the current-carrying system either temporary or permanent, shall be made, which will increase the maximum available earth fault current or its duration until it has been ascertained that the existing arrangement of earthing system are capable of carrying the new value of earth fault current which may be obtained by this addition.
7. No cut-out, link or switch other than a linked switch arranged to operate simultaneously on the earthed or earthed neutral conductor and the live conductors shall be inserted on any supply system. This however, does not include the case of a switch for use in controlling a generator or a transformer or a link for test purposes.
8. As far as the value of the earth resistance is concerned, the objective from the point of safety consideration is not to attain minimum value of the earth resistance as is sometimes understood. But the consideration should be whether there is adequate co-ordination between the practically obtainable value of the earth fault loop and setting of the protective relays.
9. An earthing arrangement may be considered electrically independent of another earthing arrangement if a rise of potential with respect to earth in one earthing arrangement does not cause an unacceptable rise of potential with respect to earth in the other earthing arrangement.
10. Concepts of earthing are explained in Fig F-1 to F-3.
  - (i) Fig. F-1: Protective and Functional equipotential bonding system with lightning protection - reproduction of figure 44 from IS732:2019
  - (ii) Fig F-2: Wrong method of earthing with separate earth electrodes - reproduction of figure 44 from IS732:2019
  - (iii) Fig F-3: Earthing of Generator and mains incoming with changeover – reproduction of figure 38 from IS3043:2018. For more information refer 39 to 41 of IS3043:2018

#### F.4 Earthing symbols, marking and application



**No. 5017 Earth:** To identify an earth terminal in cases where neither the symbol 5018 nor 5019 is explicitly stated.

**No. 5018 Functional Earth:** To identify a noiseless (clean) earth terminal, of a specially designed earthing system to avoid causing malfunction of the equipment.

**No. 5019 Protective Earth :** To identify any terminal which is intended for connection to an external conductor for protection against electrical shock in case of a fault, or the terminal of a protective earth electrode.

**No. 5020 Frame or chassis:** To identify a frame or chassis terminal. (Future name – Functional Bonding) (e.g. measure to enhance the immunity of the equipment against conducted and radiated RF disturbance - connection of sensitive electrical circuits to the chassis).

**No. 5021 Frame or chassis Equipotentiality:** To identify the terminals when connected, bring the various parts of an equipment or of a system to the same potential, not necessarily being the earth potential, e.g. for local bonding.

**All protective and functional earthing conductors should be connected to one single MET**

## **F.5 Earthing of a power supply**

### **F.5.1 System Earthing**

**F.5.1.1** Earthing of a power supply system is designed primarily to preserve the security of the system by ensuring that the potential on each conductor is restricted to such a value as is consistent with the level of insulation applied. From the point of view of safety, it is equally important that earthing should ensure efficient and fast operation of protective gear in the case of earth faults.

#### **F.5.1.2 Commonly used system earthing are TN, TT and IT.**

First letter – Relationship of the power system to earth in which

T = direct connection of one point to earth;

I = all live parts isolated from earth, or one point connected to earth through a high impedance. Second letter – Relationship of the exposed-conductive-parts of the installation to earth in which

T = direct electrical connection of exposed-conductive-parts to earth, independently of the earthing of any point of the power system;

N = direct electrical connection of the exposed-conductive-parts to the earthed point of the power system (in a.c. systems, the earthed point of the power system is normally the neutral point or, if a neutral point is not available, a line conductor).

Subsequent letter(s) (if any) – Arrangement of neutral and protective conductors:

S = protective function provided by a conductor separate from the neutral conductor or from the earthed line (or, in a.c. systems, earthed phase) conductor.

C = neutral and protective functions combined in a single conductor (PEN conductor).

#### **F.5.1.3 Definitions and considerations in each system earthing**

- (i) TN/TT system, safety is achieved by Automatic disconnection of supply.
- (ii) IT system ensure continuity of supply during first fault. This can be used for application such as hospitals, control system, safety supplies, etc. Monitoring of insulation and rectification of first fault before a second fault is essential.

- (iii) TN system – A system having one or more points of the source of energy directly earthed, the exposed conductive-parts (and extraneous conductive parts) of the installation being connected to that point by protective conductors. TN systems are further sub-divided into TN-C, TN-S and TN-C-S systems.
- (iv) TN-C system – A system in which neutral and protective conductors are combined in a single conductor throughout the system. This system shall not be used in a building.
- (v) TN-S system – A system having separate neutral and protective conductor throughout the system. (Ref. Fig F-4)
- (vi) TN-C-S system – A system in which neutral and protective conductors are combined in a single conductor in part of the system.
- (vii) TT system – A system having one point of the source of energy directly earthed, the exposed conductive-parts (and extraneous conductive parts) of the installation being connected to the earth electrodes electrically independent of the earth electrodes of the source. (ref fig. F-5)
- (viii) IT system – A system having no direct connection between live parts and earth, the exposed conductive parts of the electrical installation earthed independently or collectively. (ref fig. F-8)
- (ix) Origin of installation is also called as point of commencement of supply.
- (x) Distribution means the points in between the source and origin of installation.
- (xi) In a.c. systems, the earthed point of the power system is normally the neutral point or, if a neutral point is not available, a line conductor

**F.5.1.4** In a TN/TT system, neutral shall be earthed only at one place except in a TN-C-S system with PME (refer fig F-4 to F-6). In a TN-C-S system with PME (refer fig F-7), combined neutral and PE conductor (called as PEN conductor) shall be earthed at the source, at the distribution and at origin of installation. TN-C-S system with PME is used in public distribution, which can be applied for large housing colonies in which one transformer supplies to several houses.

**F.5.1.5** In all cases neutral conductor shall not be earthed downstream the origin of installation. The minimum insulation resistance between Neutral conductor to earth shall be 1 MΩ (remove neutral earthing to carry out the test)

## **F.5.2 Protective Equipotential Bonding (also called as Equipment Earthing).**

**F.5.2.1** The objective of equipment earthing is to ensure effective operation of the protective gear in the event of leakage through such metal work, the potential of which with respect to neighboring objects may attain a value which would cause danger to life or risk of fire.

**F.5.2.2** The earth fault loop impedance should be such that when any fault occurs against which earthing is designed to give protection, the protective gear will operate to make the faulty portions of circuit harmless. In most cases such operation involves isolation of the faulty circuit by circuit-breaker or fuses.

## **F.5.4 Earthing of Installations in Buildings**

**F.5.4.1** Maximum allowed disconnection time for prospective touch voltage ( $t$  in seconds) derived from IS 3043 are given in Table F-1.

**F.5.4.2** Maximum allowed disconnection time of an electrical installation where fault protection is achieved by protective equipotential bonding and automatic disconnection of supply is implemented is provided in table F-2. This disconnection time is applicable for final circuits in general application and dry condition. For more information refer clause 4.2.11.3 of IS732:

## **F.6 Safety by Protective Equipotential Bonding and Automatic Disconnection of the Supply**

**F.6.1** The two aims of this protective measure are to:

- (i) ensure that when an earth fault occurs, the voltages appearing between exposed conductive parts and extraneous conductive parts in the location are minimize.
- (ii) ensure rapid disconnection of the circuit in which that earth fault occurs.

**F.6.2** In order to reduce voltage appearing between exposed and extraneous conductive parts, protective equipotential bonding zones are created by connecting exposed and extraneous conductive parts to the Main earth terminal (MET or earth busbar) of the zone.

**F.6.3** An installation may consist of number of zones for instance, when an installation supplies number of buildings, equipotential bonding is necessary in each building so that each constitutes a zone having a reference point to which the exposed conductive parts of the circuits and extraneous conductive parts in that building are connected. Large buildings shall have several zones within the building

**F.6.4** Rapid disconnection of the circuit in which the earth fault occurs is met by limiting the upper value of the earth fault loop impedance of each circuit to a value determined by the type and current rating of the protective device concerned such that, on the occurrence of an earth fault (assumed to be of negligible impedance), disconnection will occur before the prospective touch voltage reaches a harmful value.

**F.6.5** It is recommended that the maximum sustained voltage developed under fault conditions between exposed metal required to be earthed and the consumer's earth terminal shall not exceed 50 V rms.

## **F.7 Safety requirements for different type of System earthing**

### **F.7.1 TN System**

**F.7.1.1:** TN systems are further sub-divided into TN-C, TN-S and TN-C-S systems. TN-C system shall not be used. TN-S is recommended in premises with own source such as transformer or DG. TN-C-S with PME is used for public distribution. (Refer figure F-4, F-6 & F-7)

**F.7.1.1:** Neutral earthing shall be preferably carried out at the mains Distribution board in a TN-S system as shown in figure F-9. This means from the source to MDB the system is like TN-C, downstream it is TN-S. The Neutral and Earth busbars of the panel to be connected through a disconnect able link. This link shall be opened while conducting insulation resistance test. CTs of Earth fault protective measures (if implemented) shall be installed in this location.

**F.7.1.1:** In a TN system, earth fault loop impedance is important for automatic disconnection of supply by an OCPD during earth fault.

**F.7.1.1** The characteristics of the protective devices and the cross-sectional area of conductors shall be so chosen that if a fault of negligible impedance occurs anywhere between a phase conductor and a protective conductor or exposed conductive part, automatic disconnection of the supply will occur within the minimum possible safe time. The time of operation would depend on the magnitude of the contact potential. As a general rule, 65 V may be cleared within 10 s and voltages of the order of 240 V and above shall be cleared instantaneously

This requirement is met if:

$$Z_s \times I_a \leq U_o$$

Where,

$Z_s$  = fault loop impedance,

$I_a$  = current ensuring the automatic operation of disconnecting device, and

$U_o$  = conventional voltage limits.

**F.7.1.2** In order that the devices will give thermal protection to the protective conductor & considering the tolerance requirement in IS 732, the condition of automatic disconnection is met if the fault loop impedance satisfies

$$Z_s (m) \leq \frac{2}{3} \times \frac{U_o}{I_a}$$

Where,

$Z_s(m)$  = the measured impedance of the fault current loop starting and ending at the point of fault ( $\Omega$ );

$U_o$  = the line conductor to earthed neutral voltage (V); and

$I_a$  = the current causing the automatic operation of the protective device within the stipulated disconnection time.

**F.7.1.3** Where the measured value of the fault loop impedance exceeds  $2 U_o / 3 I_a$ , a more precise assessment of compliance with IS 732 is recommended.

**F.7.1.4** Recommended Maximum Earth Fault Loop Impedance Values for MCB's -  $Z_s(\Omega)$  is provided in Table F-3. Fault loop impedance of every circuit shall be measured to ensure compliance.

## **F.7.2 TT system (ref fig F-5)**

**F.7.2.1** Automatic disconnection of supply during earth fault is achieved by installing a 30 mA RCD at the origin of installation. Low earth fault loop impedance cannot be efficiently fulfilled in TT system, hence OCPD's cannot be relied as a fault protective measure.

**F.7.2.2** All exposed conductive parts collectively protected by the same protective device shall be interconnected by protective conductors with an earth electrode common to all those parts. Where several protective devices are used in series, this requirement applies separately to all the exposed conductive parts protected by each device. For compliance with the requirement, the following shall be fulfilled:

$$R_A \times I_a \leq U_C$$

Where,

$R_A$  = resistance of the earthed system for exposed conductive parts,

$I_a$  = operating currents of the disconnecting series device or settings of shunt relays, and

$U_c$  = conventional voltage limit (50 V in general case and 32 V in case of relays with time lag).

**F.7.2.3** The maximum allowed residual current of RCD's in AC system is 30 mA for protection against electric shock and 300 mA for protection against fire.

**F.7.2.4** Maximum earth electrode resistance in TT system protected by RCD's and limit touch voltage < 50 V (refer Table 14 and clause 24.4 of IS 3043).

- a) 30 mA RCD = 1666 Ω
- b) 300 mA RCD = 166 Ω

**F.7.2.5** Where the HT earthing (body earthing including HV Surge Arrester) and Neutral at the LV side of the transformer is interconnected at the source, necessary measures shall be incorporated to limit the Temporary over voltages at the installation due to fault in HV system. For more information refer clause 4.5.2.2 of IS732:2019

### **F.7.3 IT System (ref. fig F-8)**

**F.7.3.1** The IT power system has all live parts isolated from earth or one point connected to earth through a high impedance. The exposed-conductive-parts of the electrical installation are earthed independently or collectively.

**F.7.3.2** The fault current is then low in the event of a single fault to an exposed conductive part or to earth and automatic disconnection in accordance is not imperative provided the condition in **F.7.3.3** is fulfilled. Provisions shall be taken, however, to avoid risk of harmful pathophysiological effects on a person in contact with simultaneously accessible exposed conductive parts in the event of two faults existing simultaneously.

**F.7.3.3** Exposed conductive parts shall be earthed individually, in groups, or collectively. The following condition shall be fulfilled:

$$R_A \times I_d \leq 50 V$$

Where,

$R_A$  is the sum of the resistance in Ω of the earth electrode and protective conductor for the exposed conductive parts.

$I_d$  is the fault current in A of the first fault of negligible impedance between a line conductor and an exposed conductive part. The value of  $I_d$  takes account of leakage currents and the total earthing impedance of the electrical installation.

**F.7.3.4** If IT system is used for continuity of supply, an insulation monitoring device (IMD) shall be provided to indicate the occurrence of a first fault from a live part to exposed conductive parts or to earth. This device shall initiate an audible and/or visual signal which shall continue as long as the fault persists. It is recommended that a first fault be eliminated with the shortest practicable delay.

**F.7.3.5** For other conditions on IT system, refer 4.2.11.6 of IS 732.

### **F.7.4 Selection of Devices for Automatic Disconnection of Supply**

**F.7.4.1** In general, every circuit is provided with a means of overcurrent protection. If the earth fault loop impedance is low enough to cause these devices to operate within the specified times (that is, sufficient current flows into the earth under fault conditions), such devices may be relied upon to give the requisite automatic disconnection of supply. If the earth fault loop impedance does not permit the overcurrent protective devices to give automatic disconnection of the supply under earth fault conditions, the first option is to reduce that impedance. It may be permissible for this to be achieved by the use of protective multiple earthing system (PME).

### **F.7.5 Exposed conductive parts to be earthed are:**

- (i) all metalwork associated with wiring system (other than current-carrying parts) including cable sheaths and armour, conduit, ducting, trunking, boxes and catenary wires,
- (ii) the exposed metalwork of all Class I fixed and portable current-using equipment, and
- (iii) the exposed metalwork of transformers used in the installation other than those that are an integral part of equipment.
- (iv) Exposed conductive parts that (because of their small dimensions or disposition) cannot be gripped or contacted by a major surface of the human body (that is, a human body surface not exceeding 50 mm × 50 mm) need not be earthed if the connection of those parts to a protective conductor cannot readily be made and reliably maintained. Typical examples of such parts are screws and nameplate, cable clips and lamp caps. Fixing screws for non-metallic accessories need not be earthed provided there is no appreciable risk of the screws coming into contact with live parts.

### **F.7.6 Extraneous conductive parts to be earthed are:**

- (i) metallic pipes supplying services into the building (for example, gas, water);
- (ii) metallic central heating and air-conditioning systems;
- (iii) structural extraneous conductive parts, if accessible in normal use;
- (iv) metallic reinforcements of constructional reinforced concrete, if reasonably practical; and
- (v) lighting protection system as per IS/IEC 62305-3.

## **F.8 Protective Equipotential bonding, Types of Protective conductors, Electrodes & Material**

Every installation shall have a protective equipotential bonding as shown in figure F-10 and F-11. Example of protective equipotential bonding in a residential building is shown in fig F-16. Protective equipotential bonding shall ensure that the fault voltages in the installation are less than the tolerable limit. Buildings with steel in concrete (or using steel columns), also to be included as a part of protective equipotential bonding.

### **F.8.1 Protective Earthing and Equipotential Bonding**

Protective Earthing is carried out by connecting Protective earth terminals / busbars of class 1 equipment in an installation to the main earthing terminal of the installation by protective earth conductors. Protective equipotential bonding is made by connecting extraneous conductive parts in an installation to the main earthing terminal of the installation by protective bonding conductors. Where such conductive parts originate outside the building, they shall be bonded as close as practicable to their point of entry within the building.

### **F.8.2 Type of Protective Conductor, Usage & Sizes**

Protective conductors are classified into Protective Earth conductor (PE), Protective bonding conductor and Earthing conductor. Earthing arrangement in a building consist of a protective equipotential bonding system connecting all protective conductors to a Main Earth Terminal (MET) as shown in figure F-10 and F-11.

**F.8.2.1** Protective Earthing Conductor: Connects MET and exposed conductive parts in the installation. E.g., PE terminals of class 1 equipment.

**F.8.2.2** Protective Bonding Conductor: Connects MET and extraneous conductive parts. They are classified into Main Protective Bonding Conductor and Supplementary Protective Bonding Conductor

**F.8.2.3** Earthing Conductor: Connects MET and earth electrodes in case of a TT system and to the means of Earthing in case of a TN system.

**F.8.2.4** MET: Main earthing Terminal, which is the equipotential bonding conductor of protective conductors, and conductors for functional earthing, if any, to the means of earthing. (e.g. a terminal or busbar that is part of the earthing arrangement of an installation and enabling the electric connection of a number of conductors used for earthing or bonding purposes)

**F.8.2.5** Copper conductors used as protective conductor, shall be of class 1 and class 2 copper conductors only. PVC (FR/FRLS/and other types) insulated wires with Class 5 copper conductors shall not be used.

**F.8.2.6 Identification of Protective conductors Use of Bi-Colour Combination — Green and Yellow**

The bi-colour combination, green and yellow (green/ yellow), shall be used for identifying the protective conductor and for no other purpose. This is the only colour code recognized for identifying the protective conductor.

Bare conductors or bus bars, used as protective conductors, shall be coloured by equally broad green and yellow stripes, each 15 mm up to 100 mm wide, close together, either throughout the length of each conductor or in each compartment or unit or at each accessible position. If adhesive tape is used, only bicoloured tape shall be applied.

For insulated conductors, the combination of the colours, green and yellow, shall be such that, on any 15 mm length of insulated conductor, one of these colours covers at least 30 percent and not more than 70 percent of the surface of the conductor, the other colour covering the remainder of that surface.

Where the protective conductor can be easily identified from its shape, construction or position, for example, a concentric conductor, then colour coding throughout its length is not necessary but the ends or accessible positions should be clearly identified by a symbol or the bi-colour combination, green and yellow.

No colour other than colour of the bare conductor is recommended from earthing conductor.

**F.8.3 Types of materials which can be used as protective conductor**

**F.8.3.1** Protective conductors may consist of one or more of the following:

- conductors in multicore cables.
- insulated or bare conductors in a common enclosure with live conductors.
- fixed installed bare or insulated conductors.

**F.8.3.2** Following metal parts are not permitted for use as protective earthing conductors or as protective bonding conductors:

- a) metallic water pipes.
- b) metallic pipes containing potentially flammable materials such as gases, liquids, powder.
- c) constructional parts subject to mechanical stress in normal service.
- d) flexible or pliable metal conduits, unless designed for that purpose.
- e) flexible metal parts.

- f) support wires, cable trays and cable ladders.
- g) Armour of cables.

**F.8.3.3** The earthing conductor (protective conductor from earth electrode up to the main earthing terminal/earth bus, as the case may be) shall be of the same material as the electrode, viz. GI or copper, and in the form of wire or strip as specified.

**F.8.3.4** Where foundation earthing is implemented, earth electrodes used in soil shall be of Copper / Stainless Steel and Copper bonded steel. (Bare or galvanized steel electrodes in soil connected directly to steel in foundation will be subjected to accelerated corrosion due to galvanic effect).

**F.8.3.5** Galvanized steel shall not be used inside concrete as it can deteriorate the concrete in wet conditions.

#### **F.8.4 Sizing of Earthing Conductor**

**F.8.4.1** Earthing conductor for connection to the neutral of the supply source in TN system, shall be sized as per clause F.8.5. In all other cases, clause F.8.4.2 applies.

**F.8.4.2** The size of earthing conductor shall not be less than the following if not buried in soil.

- (a) 4 mm dia. (8 SWG) copper wire minimum, however it need not exceed 25 mm<sup>2</sup>
  - (b) 25 mm x 4 mm in the case of GI strip, or
  - (c) 20 mm x 3 mm in the case of copper strip.
- (i) Where a bare earthing conductor is buried in the soil, its dimensions and characteristics shall also be in accordance with Table F-4. Where a lightning protection system is connected to the earth electrode, the cross-sectional area of the earthing conductor should be at least 16 mm<sup>2</sup> for copper (Cu).
  - (ii) In the case of plate earth electrode, the earthing conductor shall be securely terminated on to the plate with two bolts, nuts, check nuts and washers.
  - (iii) In the case of pipe earth electrode, wire type earthing conductor shall be secured using a through bolt, nuts and washers and terminating socket.
  - (iv) A double C-clamp arrangement shall be provided for terminating tape type earthing conductor with GI watering pipe coupled to the pipe earth electrode. Galvanized "C" shaped strips, bolts, washers, nuts and check nuts of adequate size shall be used for the purpose.
  - (v) The earthing conductor from the electrode up to the building shall be protected from mechanical injury by a medium class, 15 mm dia. GI pipe in the case of wire, and by 40 mm dia, medium class GI pipe in the case of strip. The protection pipe in ground shall be buried at least 30 cm deep (to be increased to 60 cm in case of road crossing and pavements). The portion within the building shall be recessed in walls and floors to adequate depth in due co-ordination with the building work.
  - (vi) The earthing conductor shall be securely connected at the other end to the MET of the building by:
    - (a) Soldered or preferably crimped lug, bolt, nut and washer in the case of wire, and
    - (b) Bolt, nut and washer in case of strip conductor.

In the case of sub-stations or alternators, the termination shall be made on the earthing terminal of the neutral point on the equipment and/or the earth bus, as the case may be.

### **F.8.5 Sizing of Protective Earth Conductor**

**F.8.5.1** Substantial amount of fault current flows through the PE conductor. Hence it shall be selected based on the expected fault current, and condition of installation. The material and size of protective earth conductors shall be as specified in table F-5:

**F.8.5.2** Since the practice is to use bare conductor as protective conductor, Values of k for bare conductors where there is no risk of damage to any neighbouring material by the temperature indicated is provided in table F-6 and F-7 and the example thereof. For other applications use annex EE of IS:732 or from Table 11A to D of IS:3043.

### **F.8.6 Sizing of Protective bonding conductors**

Protective bonding conductors are classified into Main Protective bonding conductor and Supplementary Protective bonding conductor. Main protective bonding is necessary for every metallic incoming service into a building. Supplementary protective bonding is necessary to limit the fault voltage at inner locations of a building. Main protective bonding is mandatory in every building.

#### **F.8.6.1 Main Protective bonding conductor**

Protective bonding conductors for connection to the MET shall have a cross sectional area not less than half the cross-sectional area of the largest protective earthing conductor within the installation and not less than:

- 6 mm<sup>2</sup> copper; or
- 16 mm<sup>2</sup> aluminium; or
- 50 mm<sup>2</sup> steel.

The cross-sectional area of protective bonding conductors for connection to the main earthing terminal need not exceed 25 mm<sup>2</sup> Cu or an equivalent cross-sectional area for other materials.

#### **F.8.6.2 Supplementary protective bonding conductors**

- (i) A protective bonding conductor connecting two exposed-conductive-parts shall have a conductance not less than that of the smaller protective conductor connected to the exposed conductive- parts.
- (ii) A protective bonding conductor connecting exposed-conductive-parts to extraneous conductive-parts shall have a conductance not less than half that of the cross-sectional area of the corresponding protective conductor.
- (iii) The minimum cross-sectional area of protective bonding conductors for supplementary bonding, and of bonding conductors between two extraneous-conductive parts, shall be
  - 2,5 mm<sup>2</sup> Cu or 16 mm<sup>2</sup> Al if protection against mechanical damage is provided,
  - 4 mm<sup>2</sup> Cu or 16 mm<sup>2</sup> Al if protection against mechanical damage is not provided.

**F.8.7** Main Earth Terminal (MET): The minimum size of the MET shall be as per clause 8.5. Locations where various protective conductors are connected to MET shall be of at least double the size of requirement to take care of reduction in conductive area due to drilling of holes in busbars.

### **F.8.8 Electrical Continuity of Protective Conductors (also explained as Loop Earthing/ Earth Continuity Conductor)**

(i) Protective conductors shall be suitably protected against mechanical damage, chemical

or electrochemical deterioration, electrodynamic forces and thermodynamic forces. Every connection (for example, screwed connections, clamp connectors) between protective conductors or between a protective conductor and other equipment shall provide durable electrical continuity and adequate mechanical strength and protection. Screws for connecting protective conductors shall not serve any other purpose. Joints shall not be made by soldering.

- (ii) All electrical connections should have sufficient thermal capacity and mechanical strength to withstand any combination of current/time which may occur in the conductor or in the cable/enclosure with the largest cross-sectional area.
- (iii) Earth terminal of every switchboard in the distribution system shall be bonded to the protective equipotential bonding system as shown in figure F-12. Two protective earth conductors shall be provided for a switchboard carrying a 3-phase switchgear thereon while connecting to the protective equipotential bonding.
- (iv) The exposed conductive part associated with every distribution board (DB) shall be securely connected to the earth terminal/ earth bar of the corresponding switch board by a protective conductor of adequate size.
- (v) The earth pin of socket outlets as well as metallic body of fan regulators shall be connected to the earth terminal in switch boxes by protective conductor. Where the switch boxes are of non-metallic type, these shall be looped at the socket earth terminals, or at an independent screwed connector inside the switch box. Twisted earth connections shall not be accepted in any case.

#### **F.8.9 Earth electrodes**

Type of earth electrodes which may be used are:

- a) Concrete-embedded foundation earth electrode,
- b) Soil-embedded foundation earth electrode,
- c) Metallic electrode embedded directly in soil vertically or horizontally (for example, rods, wires, tapes, pipes or plates),
- d) Other suitable underground metalwork (for example, pipes) according to local conditions or requirements,
- e) Metal reinforcement of concrete (except pre-stressed concrete) embedded in the earth,
- f) Ring earth electrode as a closed loop all around the building.

For all new buildings, foundation earth electrode is recommended.

The materials and minimum sizes of earth electrodes shall be as per Table-4. More information can be found on IS732.

#### **F.8.9.1 Location for Earth Electrodes other than concrete embedded foundation earth electrodes.**

- (i) Normally an earth electrode shall not be located closer than 1.5 m from any building. Care shall be taken to see that the excavation for earth electrode does not affect the foundation of the building; in such cases, electrodes may be located further away from the building, with the prior approval of the Engineer-in-charge.
- (ii) The location of the earth electrode will be such that the soil has a reasonable chance of remaining moist as far as possible. Entrances, pavements and roadways, should be avoided for locating earth electrodes.

#### **F.8.9.2 Installation**

- (i) Vertical earth electrodes
  - a. Best performances are achieved by hammering solid rod / pipe in soil. This is possible only in soil without gravel / stones.

- b. Solid rod or Pipe electrode shall be buried in the ground vertically with its top at not less than 20 cm below the ground level. The installation shall be carried out as shown in Fig. F-17.
- c. In locations where the full length of solid rod / pipe electrode is not possible to be installed due to meeting a water table, hard soil or rock, the electrode may be of reduced length, provided the required earth resistance result is achieved with or without additional electrodes, or any alternative method of earthing may be adopted, with the prior approval of the Engineer-in-charge. Pipe electrodes may also be installed in horizontal formation in such exceptional cases.
  - (ii) Plate electrode shall be buried in ground with its faces vertical, and its top not less than 3.0 m below the ground level. The installation shall be carried out as shown in Fig.F-18.
  - (iii) When more than one electrode (plate/pipe) is to be installed, a separation of not less than 3 m shall be maintained between two adjacent electrodes.
  - (iv) The strip or conductor electrode shall be buried in trench not less than 0.5 m deep.
  - (v) If conditions necessitate the use of more than one strip or conductor electrode, they shall be laid as widely distributed as possible, in a single straight trench where feasible, or preferably in a number of trenches radiating from one point.
  - (vi) If the electrode cannot be laid in a straight length, it may be laid in a zigzag manner with a deviation up to 45 degrees from the axis of the strip. It can also be laid in the form of an arc with curvature more than 1 m or a polygon.

**F.8.9.3** Artificial treatment of soil shall be applied only in places where the soil resistivity is higher than 3000  $\Omega$ m. When artificial treatment of soil is to be resorted to, the same shall be specified in the schedule of work. Artificial treatment of soil shall not be carried out where the soil resistivity is less than 200  $\Omega$ m as this increases the corrosion of the electrode material.

**F.8.9.4** When selecting the type and embedded depth of an earth electrode, consideration shall be given to possible mechanical damage and to local conditions to minimize the effect of soil drying and freezing.

**F.8.9.5** Consideration shall be given to electrolytic corrosion when using different materials in an earthing arrangement. For external conductors (for example, earthing conductor / earth electrode) connected to a concrete-embedded foundation earth electrode, the connection made from hot-dip galvanized steel shall not be embedded in the soil (GI earth electrodes in soil are subjected to accelerated corrosion when connected with steel in reinforcement).

**F.8.9.6** The earthing arrangement shall not rely on a metallic pipe for flammable liquids or gases as the earth electrode and their buried length shall not be considered when dimensioning the earth electrode.

**F.8.9.7** Earth electrodes shall not be directly immersed in water of a stream, river, pond, lake.

**F.8.9.10** The connection of various conductors in an earthing arrangement shall be soundly made and electrically satisfactory. The connection shall be by exothermic welding, pressure connectors, clamps or other suitable mechanical connectors. Mechanical connectors shall be installed in accordance with the manufacturer's instructions. Where a clamp is used, it shall not damage the electrode or the earthing conductor.

**F.8.9.11 Services entering a building**

Metal pipes (e.g. water, gas, HVAC) and incoming power and signal cables should preferably enter the building at the same place. Metal pipes and the metal armouring of

cables shall be bonded to the main earthing terminal by means of conductors having low impedance; see Figure F-11.

## **F.9 Earthing of premise with own transformer and DG**

**F.9.1** Earthing system in the premises at voltages above 230 V should be designed as a PME system with separate protective conductor (TN-S). Protective multiple earthing system is made in order to reduce the earth fault loop impedance and to ensure reliable disconnection of supply during an earth fault by the OCPD. In PME system, neutral of the supply transformer and the non-current carrying metal parts in the system are interconnected by the common earth grid in addition to the separate protective conductor as a shown in fig F-6.

**F.9.2** In TN system, there is no need to design the vertical earth electrodes (such as rods and plates) in soil for the appropriate thermal withstand capacity, assuming the total fault current to be passing through these earth electrodes. System recommended in IS 3043 is a TN-S system with PME, where the neutral of the source and exposed conductive parts in the installation are solidly connected to the MET and an earthing grid. In this interconnected system, earth fault current is returned to the neutral mostly through the interconnected system consisting of the PE conductor and earth grid.

**F.9.3** The disposition of the earth electrodes and the extent and size of earth grid will always depend upon the disposition of plant electrics. The layout should be done in such a manner as to keep the earth continuity resistance to within the stipulated level.

**F.9.4** Equipotential Bonding Conductor and Protective Earth (PE) conductor shall run as close as possible and parallel to line conductors.

**F.9.5** The continuity resistance of the earth return path through the earth grid should be maintained as low as possible (depending up on the fault loop impedance of that part of the circuit) and in no case greater than one ohm.

**F.9.6** In case of EHT substations (above 66 kV), where there is possibility of the ground potential attaining very high values (of the order of 5 kV and above) in the event of an earth fault, the earth grid design should be based on the tolerable limits of the potential gradient in the substation area, and the step and touch potential due to fault conditions.

## **F.10 EARTHING OF SYSTEM EXCEEDING 1 kV**

**F.10.1** Design of an earthing system for voltages exceeding 1 kV shall be made as a Global earthing system. An earthing system interconnecting HV and LV earthing system as recommended in IS3043 is explained in fig F-13 A to Fig F-13.C.

**F.10.2** Additional steps to be followed for application above 33 kV to fulfil the step and touch voltage calculations as per clause F.9.6 are as below. If Global Earthing System is implemented, detailed calculation of step and touch potential calculations are not necessary.

- (i) Data collection, for example, earth fault current, fault duration and layout.
- (ii) Initial design of the earthing system based on the functional requirements.
- (iii) Determine if it is part of a global earthing system.
- (iv) If not, determine soil characteristics e.g. Specific soil resistivity of layers.
- (v) Determine the current flowing into earth from the earthing system, based on earth fault current.

- (vi) Determine the overall impedance to earth, based on the layout, soil characteristics, and parallel earthing systems.
- (vii) Determine earth potential rise.
- (viii) Determine permissible touch voltage.
- (ix) If the earth potential rise is below the permissible touch voltage and the requirements of fig F-14 are met the design is complete.
- (x) If not, determine if touch voltages inside and in the vicinity of the earthing system are below the tolerable limits.
- (xi) Determine if transferred potentials present a hazard outside or inside the electrical power installation; if yes, proceed with mitigation at exposed location.
- (xii) Determine if low-voltage equipment is exposed to excessive stress voltage, if yes, proceed with mitigation measures which can include separation of HV and LV earthing systems.

**F.10.3** Flowchart of this design of earthing system above 1 kV is given in Fig F-15. For more information refer IS/IEC 61936-1.

**F.10.4** The structural earth electrode shall be bonded and form part of the earthing system. If not bonded, verification is necessary to ensure that all safety requirements are met. Metallic structures with cathodic protection may be separated from the earthing system. Precautions, such as labelling, shall be taken to ensure that when such measures are taken, maintenance work or modifications will not inadvertently nullify them.

## **F.11 Erection of concrete-embedded foundation earth electrodes**

### **F.11.1 General**

Concrete used for the foundations of buildings has a certain conductivity and generally a large contact area with the soil. Therefore, bare metal electrodes completely embedded in concrete can be used for earthing purposes, unless the concrete is isolated from the soil by use of waterproof membrane or special thermal insulation or other measures. Due to chemical and physical effects, metals embedded in concrete to a depth of more than 5 cm are highly protected against corrosion, normally for the whole lifetime of the building.

Wherever possible, the conductive effects of the reinforcement of the building should also be used. The production of a concrete-embedded foundation earth electrode during the erection of the building may be an economical solution to obtain a good earth electrode of long standing because:

- (i) It does not necessitate additional excavation works.
- (ii) It is erected at a depth which is normally free from negative influences resulting from seasonal weather conditions.
- (iii) It provides a good contact with the soil.
- (iv) It extends over practically all of the building's foundation surface and results in the minimum earth electrode impedance which can be obtained with this surface.
- (v) It provides an optimal earthing arrangement for lightning protection system purposes.
- (vi) From the beginning of the erection of the building, it can be used as an earth electrode for the electrical installation of the construction site.

Besides its earthing effect, the concrete-embedded foundation earth electrode provides a good basis for the main protective bonding.

The following requirements and advice for the erection of a concrete-embedded foundation earth electrode apply.

**F.11.2 Other considerations regarding the use of concrete-embedded foundation earth electrodes**

If the building foundation is to be completely protected against water leakages by using certain insulating materials, for example, using plastic sheets of more than 0.5 mm thickness, earthing using the foundation concrete is not viable. In such cases, the positive effect of metal reinforcement for protective bonding may be used, and for earthing purposes another earthing arrangement should be used, e.g. an additional concrete-embedded foundation earth electrode below the isolated foundation, or an earthing arrangement around the building or a soil-embedded foundation earth electrode.

**F.11.3 Construction of concrete-embedded foundation earth electrodes**

**F.11.3.1** For concrete foundations without metal reinforcement, the concrete-embedded foundation earth electrodes must be coordinated with the type and dimensions of the foundation. One or more closed ring(s) or rectangles with dimensions up to 20 m and mutually connected are preferred.

**F.11.3.2** To avoid embedding of the electrodes in concrete at less than 5 cm depth, suitable means for the distance of the electrode wiring above the ground should be used. If strips are used as electrodes, they should be fixed set up on edge to avoid holes without concrete under the strip. If reinforcement is present, the wiring should be fixed to it at intervals of not more than 5 m. The connections should be made by exothermic welding, pressure connectors, clamps or other suitable mechanical connectors. Mechanical connectors shall be installed in accordance with the manufacturer's instructions. Where a clamp is used, it shall not damage the electrode or the earthing conductor. Connection devices or fittings that depend solely on solder shall not be used independently, as they do not reliably provide adequate mechanical strength. The use of keyed joints should be avoided.

**F.11.3.3** The wiring of the concrete-embedded foundation earth electrode should have at least one terminal lug for connection to the electrical system of the building, either leaving the concrete inside the building to a suitable connection point (for example, to the main earthing terminal) or ending at a special connection clamp embedded in concrete of a wall at its surface. At the point of connection, the terminal lug must be accessible for maintenance and measuring purposes.

**F.11.3.4** For lightning protection and for buildings with special requirements concerning information technology, more than one terminal lug of the foundation earth electrode, for example, for lightning protection system down-conductors, may be needed.

**F.11.3.5** Metal reinforcement of the foundations of the building may be used as an electrode provided it is soundly connected. For welded connections the permission of the responsible person for the structural design and analysis of the construction of the building is required. Connections made by a wrapped iron wire only are not suitable for protection purposes but may be sufficient for EMC purposes for information technology. Prestressed reinforcement must not be used as an electrode.

**F.11.3.6** The wiring of the electrodes should not go over joints between different parts of larger foundations. At such places, suitable malleable connectors should be installed outside the concrete to provide the necessary electrical connections.

**F.11.3.7** Concrete-embedded foundation earth electrodes of single foundations (for example, for the construction of large halls) should be connected to other parts of the concrete-embedded foundation earth electrode by using suitable earthing conductors.

**F.11.4 Possible corrosion problems for other earthed installations outside concrete-embedded foundation earth electrodes**

Attention is drawn to the fact that ordinary steel (bare or hot-dip galvanized) embedded in concrete results in an electrochemical potential equal to that of copper embedded in the soil. Consequently, there is a danger of electrochemical corrosion occurring to other earthing arrangements made from steel embedded in the soil near the foundation and being in connection with a concrete-embedded foundation earth electrode. This effect can also be found with reinforced foundations of large buildings.

Any steel electrode must not be installed directly from foundation concrete into the soil except for electrodes made from stainless steel, copper or copper bonded steel. Hot-dip galvanized covering or protection by painting or other similar materials later on is not sufficient for such purposes. Additional earthing arrangements around and near such buildings should be made from other than hot-dip galvanized steel so as to provide a sufficient life-time for this part of the earthing arrangement.

**F.11.5 Completion of concrete-embedded foundation earth electrodes**

**F.11.5.1** After preparing the electrodes and/or the connected reinforcement, but before the concrete is poured, a survey and documented record of the arrangement should be made by a skilled person. The documentation should contain a description, plans and photos and should form a part of the whole documentation for the electrical installation (*see IS 732*).

**F.11.5.2** Concrete used for the foundation should be made from at least 240 kg cement per m<sup>3</sup> concrete. The concrete must have a suitable semi-liquid consistency to fill all holes below the electrodes.

**F.12 Functional earthing and functional-equipotential-bonding for Information and communication technology equipment and systems (ICT)**

**F.12.1 Functional-equipotential-bonding for ICT comprise of**

- functional earthing conductor(s),
- functional bonding conductor(s),
- a main functional earthing terminal.

Where the functional-equipotential-bonding system is not locally connected to the protective equipotential-bonding system, the functional bonding conductors shall be

- insulated, cram colour and
- installed separately from the protective conductor, and
- connected to the main earthing terminal only once.

The functional-bonding-conductors are insulated because those conductors could under certain circumstances achieve a dangerous potential.

If there are multiple functional bonding conductors present in the electrical installation, a separate main functional earthing terminal (MFET) shall be installed for ease of connection for these conductors. The main functional earthing terminal shall be connected to the main earthing terminal only once.

The cross-sectional area of every functional bonding conductor or functional earthing conductor shall be capable of withstanding all mechanical and thermal stresses caused by the expected operational current. This current shall be determined in accordance with the manufacturer's instructions or by measurement taking into account the ICT equipment or system.

#### **F.12.2 Minimum cross-sectional area**

In the absence of requirements, for example stated by the equipment manufacturer, the following minimum cross-sectional area shall be applied for functional earthing conductors and functional bonding conductors:

- 2,5 mm<sup>2</sup> Cu or 16 mm<sup>2</sup> Al, if protection against mechanical damage is provided,
- 4 mm<sup>2</sup> Cu or 16 mm<sup>2</sup> Al, if protection against mechanical damage is not provided.

Larger cross-sectional areas can be specified for EMC reasons for installation with large number of ICT equipment in a concentrated area. Recommendations in ISO/IEC 30129 shall be followed in such cases.

#### **F.12.2 Identification**

A functional earthing conductor shall be identified by:

- the alphanumeric notation FE.
- by the colour cream at least applied at the terminations and points of connection, or
- by the symbol 5018 (ref clause F4).

A functional bonding conductor shall be identified by:

- the alphanumeric notation FB.
- by the symbol 5020 (ref clause F4).

The alphanumeric notation and the colour marking are in accordance with IEC 60445. The bi-colour combination GREEN-AND-YELLOW shall not be used to identify functional bonding conductors.

If part of an item of equipment can be removed, the functional bonding conductor for the remaining part of the electrical installation shall not be disconnected.

#### **F.12.3 Combined protective and functional bonding conductors**

Where a combined protective and functional bonding conductor is used, it shall fulfil all requirements for a protective bonding conductor. The combined protective and functional bonding conductor shall be identified by the bi-colour combination GREEN-AND-YELLOW.

#### **F.12.4 Main functional earthing terminal (MFET)**

The following conductors shall be connected to the main functional earthing terminal (MFET), if any:

- a. functional earthing conductors.
- b. functional bonding conductors.

The main functional earthing terminal (MFET) and the main earthing terminal (MET) may be Combined.

#### **F.12.4 Equipotential bonding ring conductors**

The main earthing terminal (MET) may be provided as a ring (closed loop) conductor to enable systems of information technology and communications equipment (ICT) to be incorporated into the equipotential bonding system using the shortest connection. The

equipotential bonding ring conductor shall be easily accessible wherever connections may be required. The cross-sectional area of equipotential bonding ring conductors shall comply with Protective Earth conductor (PE), or:

- be at least 50 mm<sup>2</sup> hot-dip galvanized steel strip, or
- be at least 16 mm<sup>2</sup> copper, or
- be a cross-sectional area in another material, which provides at least a conductivity equivalent to 16 mm<sup>2</sup> copper.

For more information on functional earthing, refer IS732.

### **F.13 Additional requirements of earthing in medical locations**

The requirements in clause F.13 shall be read as additional requirements

Medical locations are classified into Group 0, Group 1 and Group 2 in the IS 17512:2021.

- Group-0: Medical location where medical electrical equipment can be brought into contact with the patient or needs to be touched by the patient.
- Group 1 is a location where medical electrical equipment used externally.
- Group 2 is a location where medical electrical equipment are used in applications such as intracardiac procedures, operating theatres and vital treatment where discontinuity of the supply can cause danger to life.

#### **F.13.1 General requirements**

TN-S type electrical distribution shall be followed, where exposed and extraneous conductive parts is connected to the earthed point of the neutral through protective conductor.

The maximum tripping time of protective device for a 230 Volt fault shall not be more than 0.2 seconds and touch voltage shall not exceed 50 V in group 0 medical location. In medical locations of group 1 and group 2, the conventional touch voltage shall not exceed 25 V.

#### **F.13.2 Supplementary protective equipotential bonding**

In each medical location of group 1 and group 2, a supplementary protective equipotential bonding system shall be installed, and the supplementary protective bonding conductors shall be connected to the equipotential bonding busbar for the purpose of equalizing potential differences between the following parts located within the patient environment:

- extraneous-conductive-parts, unless they are intended to be isolated from earth.
- screens against electrical interference fields, if installed.
- connection to conductive floor grids, mesh and tapes, including those for static protection, if installed.
- metal screens of isolating transformers, cable shields, etc., via the direct path to the protective earthing conductor.

**F.13.3** Conductive parts intended to be isolated from earth shall not be connected to supplementary protective equipotential bonding. Supplementary equipotential bonding connection points for the connection of Medical Electrical equipment shall be available in group 2 locations and considered in group 1.

**F.13.4** In medical locations of group 1 and group 2, the resistance between simultaneously accessible exposed-conductive-parts, including the terminals for the protective conductor of socket-outlets and of fixed equipment, extraneous conductive parts and the equipotential bonding points shall be of such a value shall not exceed 0.2 Ω. The limit

of  $0.2 \Omega$  is based on the use of a type B miniature circuit breaker rated current of 25 A to achieve the conventional touch voltage of 25 V AC. If other type of MCB's are used, a lower continuity resistance is preferred.

**F.13.5** The equipotential bonding busbar shall be located within or near each medical location of group 1 and group 2. Connections shall be so arranged that they are accessible, labelled, clearly visible and that they can easily be individually disconnected.

### **F.13 Additional requirements of earthing in information technology and communications equipment (ICT)**

#### **F.13.1 Introduction**

Electromagnetic Interference (EMI) may disturb or damage information technology systems or information technology equipment as well as equipment with electronic components or circuits. Currents due to lightning, switching operations, short-circuits and other electromagnetic phenomena may cause overvoltage and electromagnetic interference. These effects are most severe,

- where large metal loops exist; and
- where different electrical wiring systems are installed in common routes, e.g. for power supply and for signalling information technology equipment within a building.

The value of the induced voltage depends on the rate of rise ( $di/dt$ ) of the interference current, and on the size of the loop.

Power cables carrying large currents with a high rate of rise of current ( $di/dt$ ) (e.g. the starting current of lifts or currents controlled by rectifiers) can induce overvoltage in cables of information technology systems, which can influence or damage information technology equipment or similar electrical equipment.

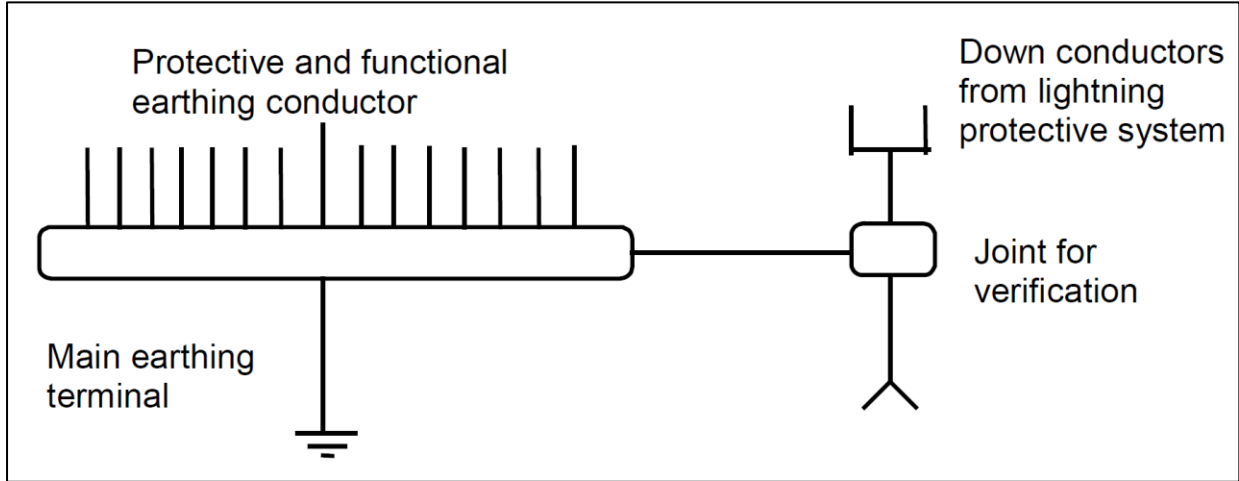
In or near rooms for medical use, electric or magnetic fields associated with electrical installations can interfere with medical electrical equipment.

#### **F.13.2 Special requirements**

For existing installations, suitable bonding network as per IS732 clause 4.5.4.5.3 shall be use. For new buildings Common Mesh Bonding Network (Mesh-BN) shall be adopted. For more information refer ISO/IEC 30129.

**Fig F-1**  
**(Clause F-3)**

**Protective and Functional equipotential bonding system with lightning protection - reproduction of figure 44 from IS732:2019**



**Fig F-2**  
**(Clause F-3)**

**Wrong method of earthing with separate earth electrodes - reproduction of figure 44 from IS732:2019**

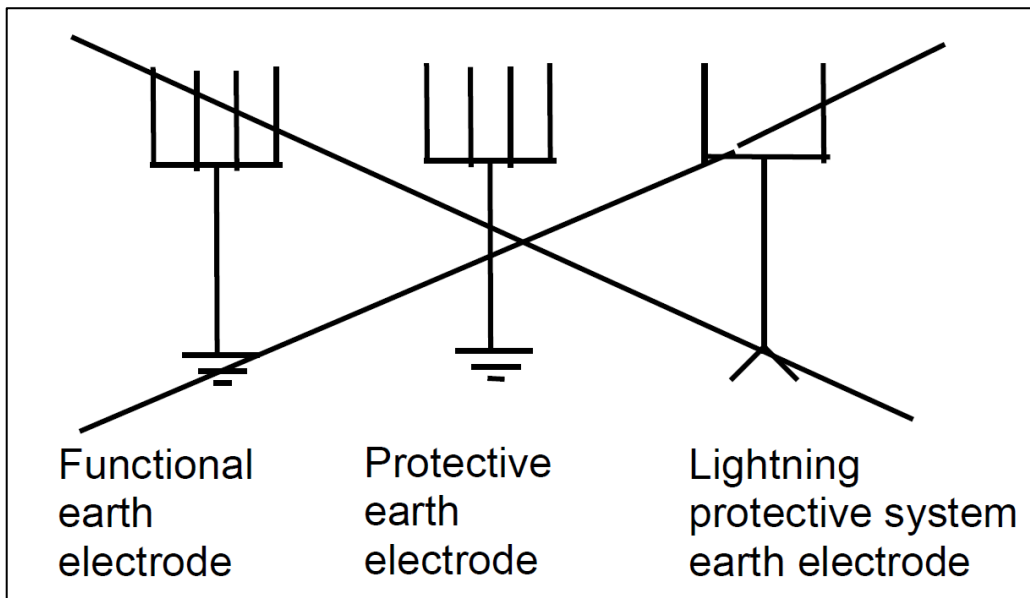
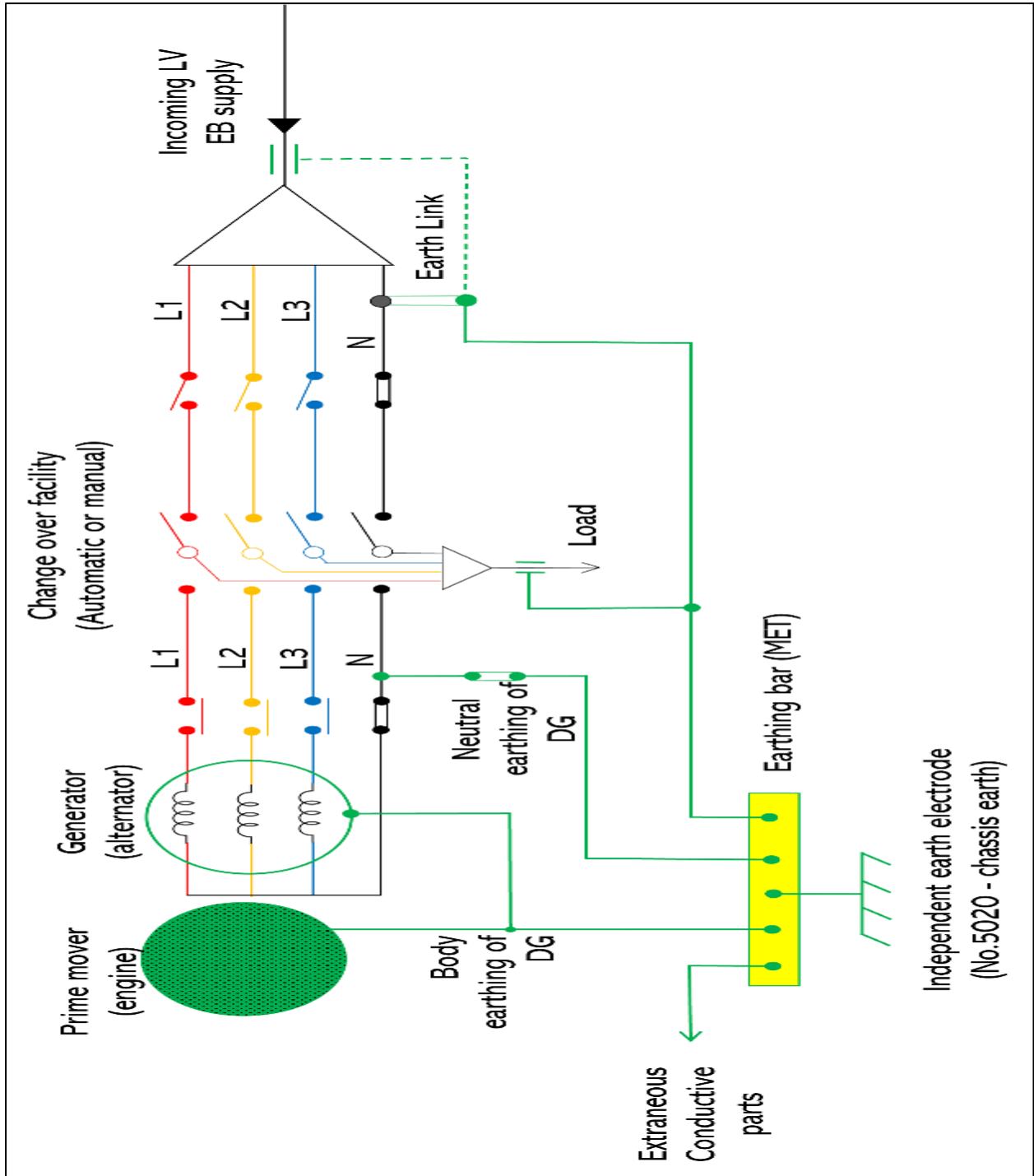


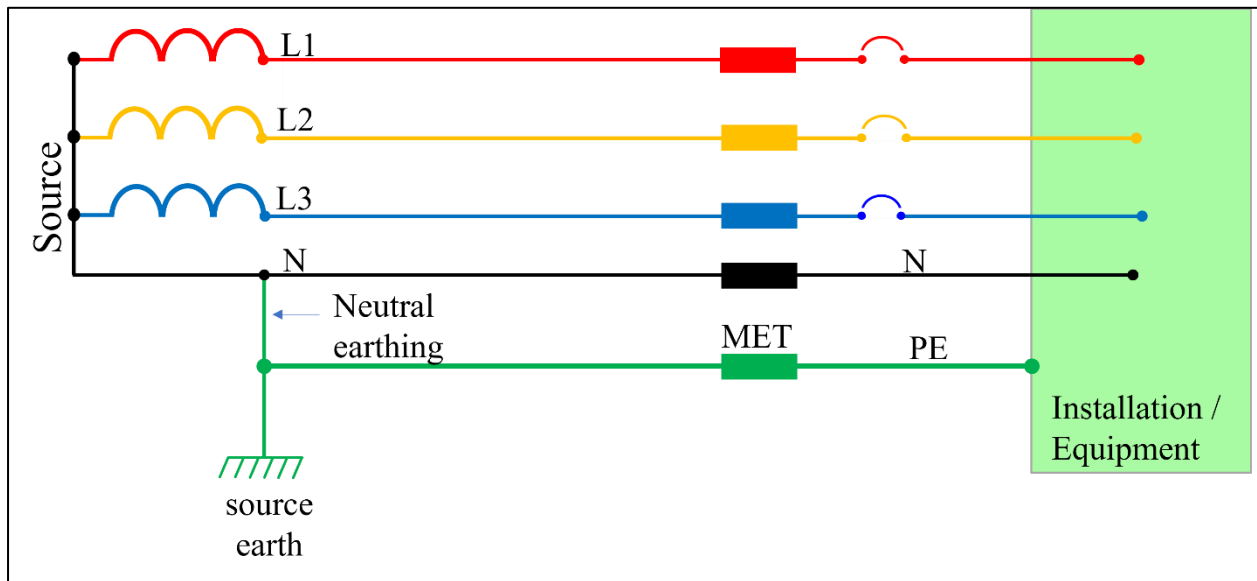
Fig F-3

(Clause F-3)

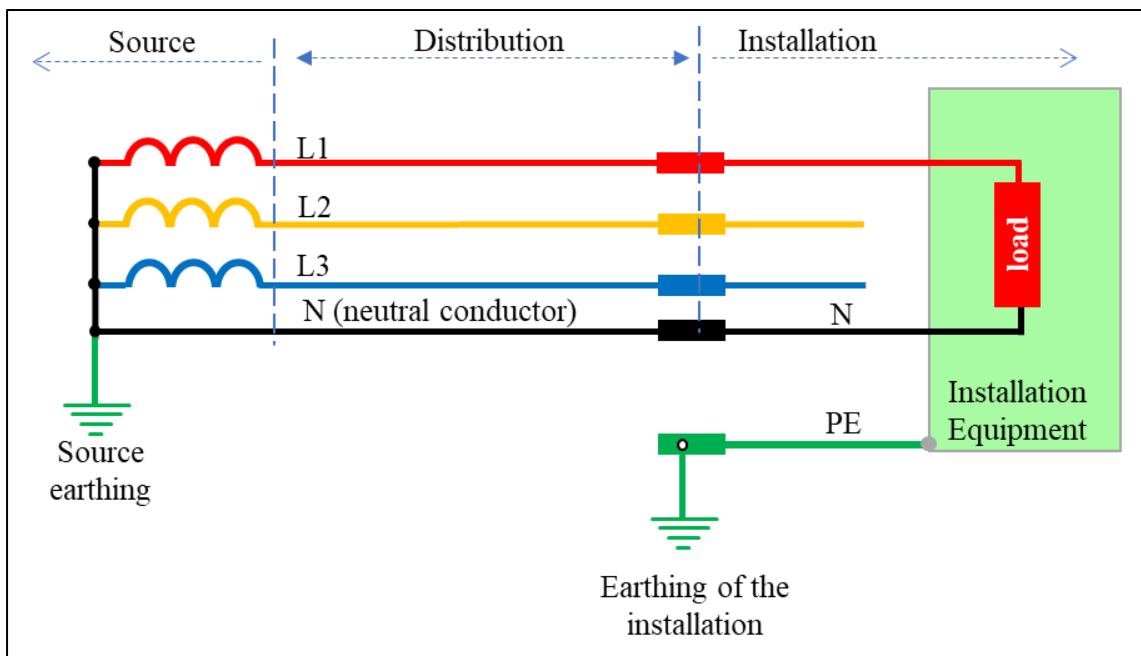
Earthing of Generator and mains incoming with changeover – reproduction of figure 38 from IS3043:2018



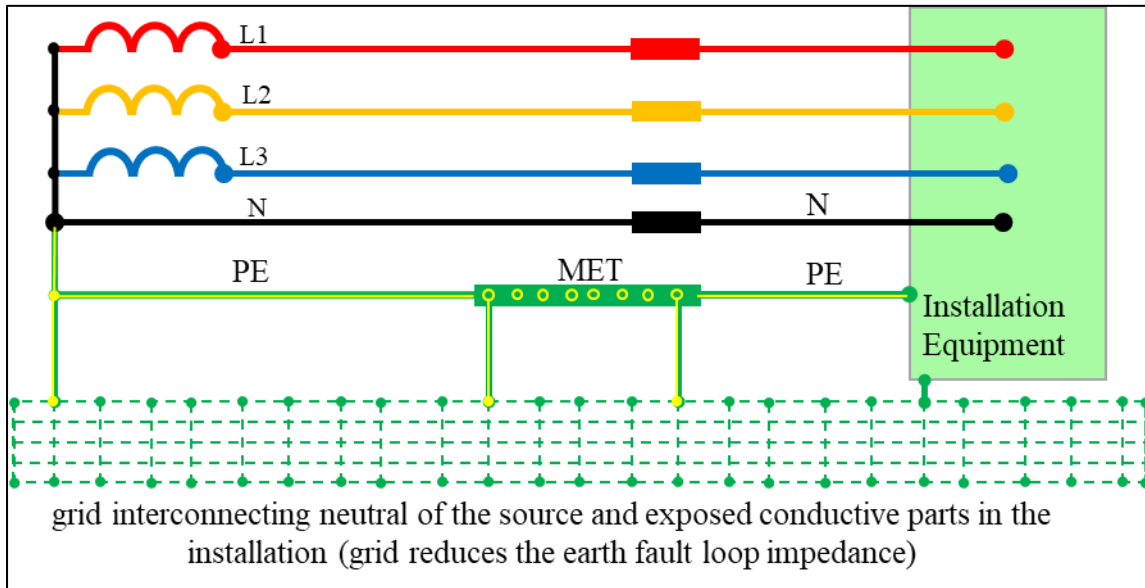
**Fig F-4**  
**(Clause F-5.1.3(v))**  
**TN-S system with separate Neutral (N) and Protective Conductor (PE)**



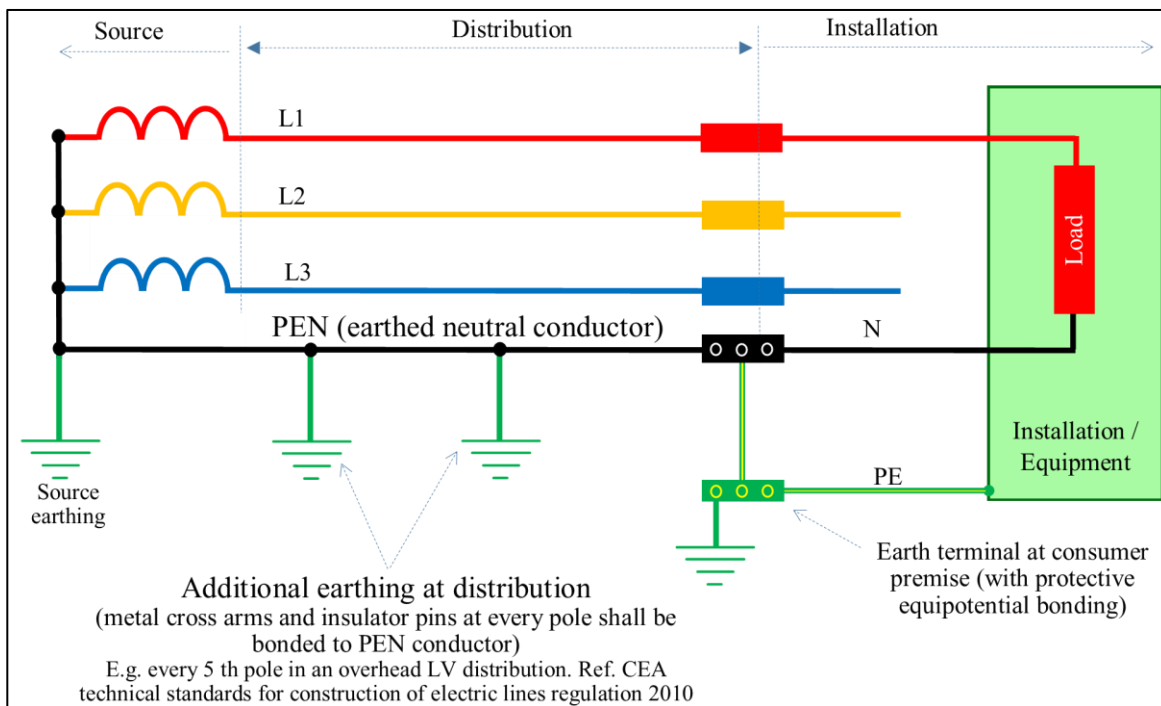
**Fig F-5**  
**(Clause F-5.1.3(vii), F-7.2)**  
**TT system (public distribution)**



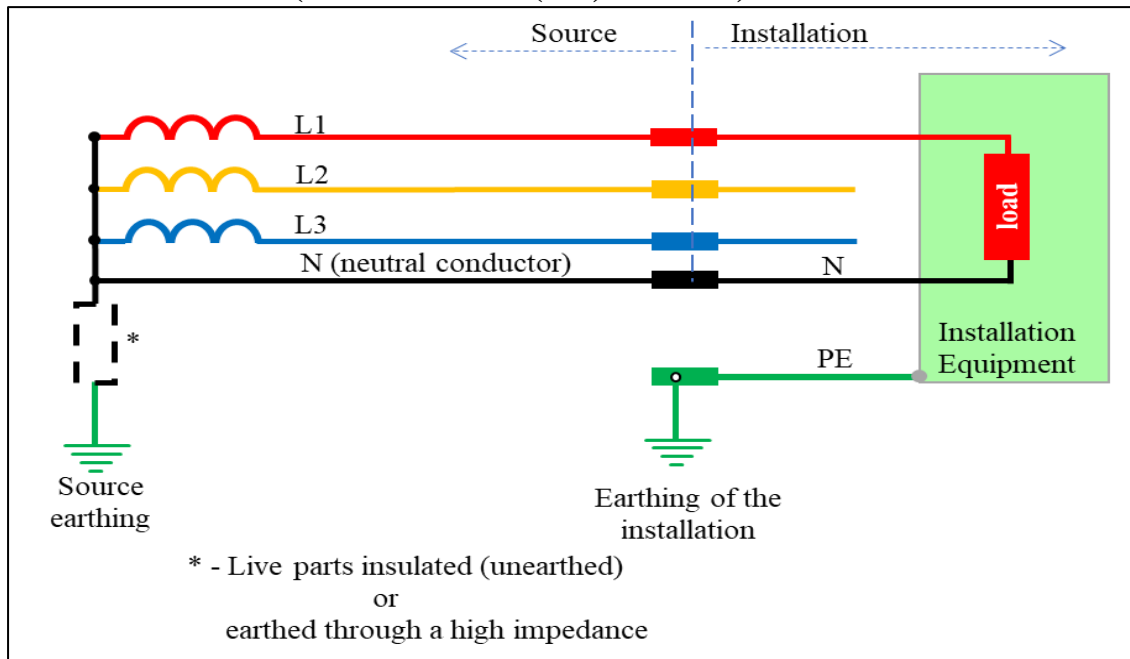
**FIG F-6**  
**(Clause F-5.1.4, F-9.1)**  
**SYSTEM WITH SEPARATE EARTH CONDUCTOR (TN-S) &**  
**PROTECTIVE MULTIPLE EARTHING (PME)**



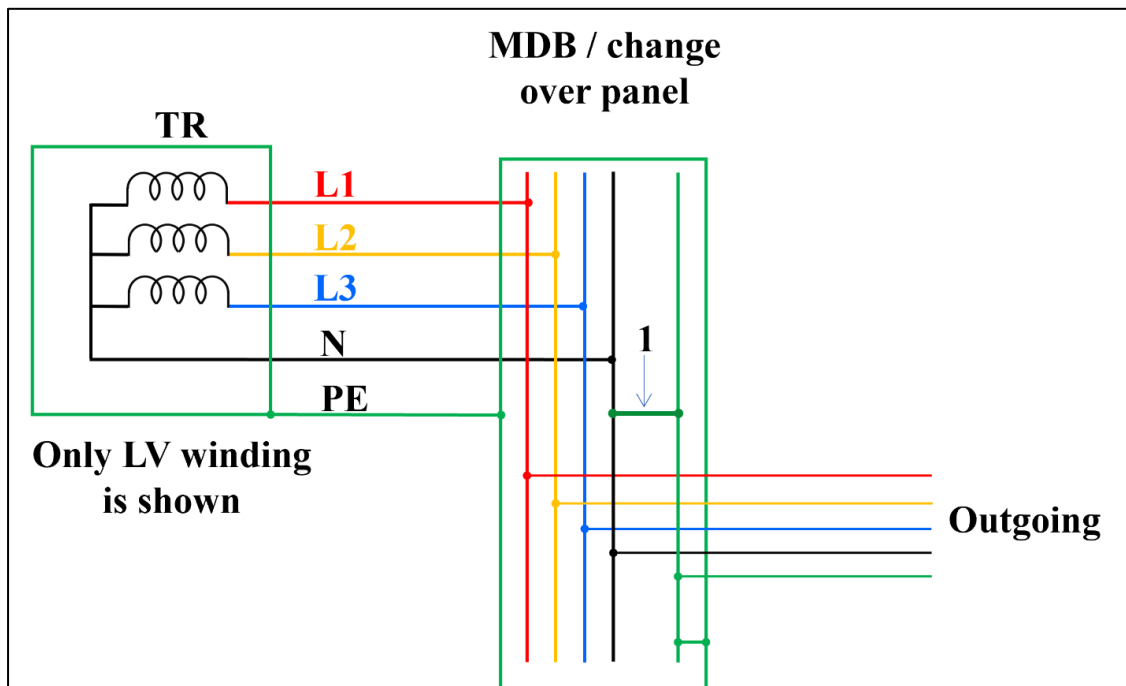
**FIG F-7**  
**(Clause F-5.1.4)**  
**TN-C-S SYSTEM WITH PROTECTIVE MULTIPLE EARTHING**  
**(PME)**



**FIG F-8  
IT SYSTEM  
(Clause F-5.1.3(viii) & F-7.3)**

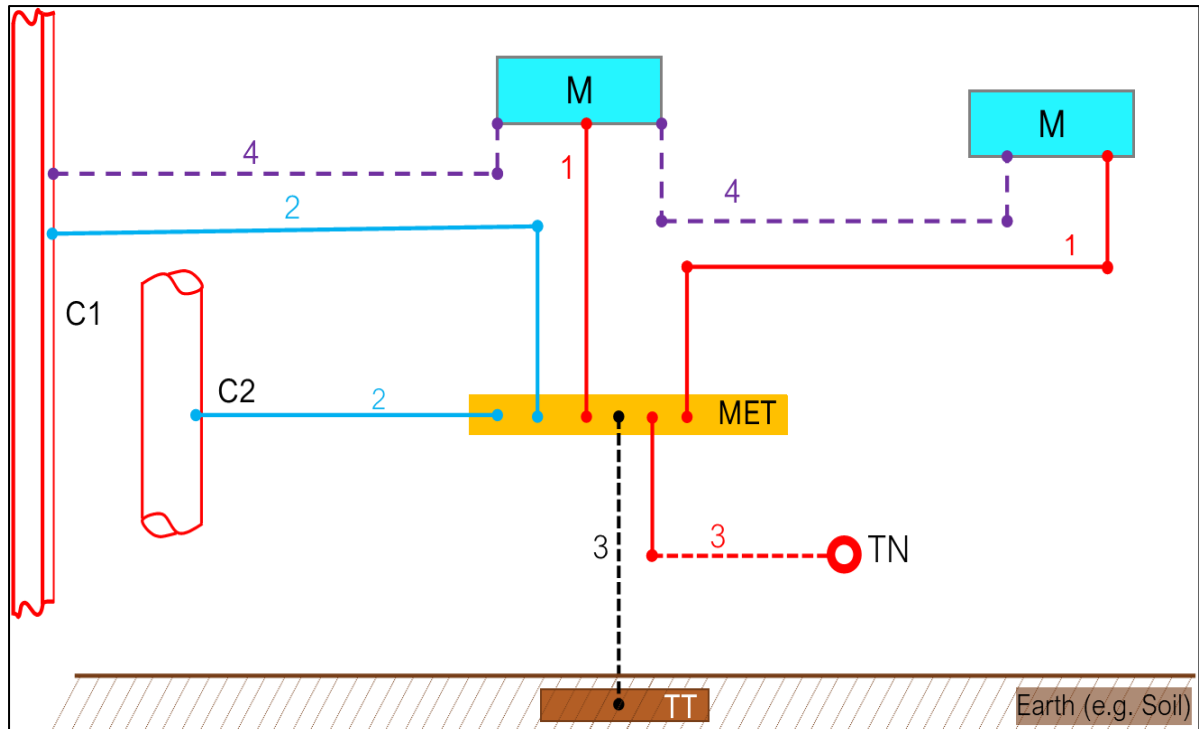


**Fig F-9  
Ideal location for Neutral earthing of source  
(Clause F-7.1.1)**



Neutral earthing of the source to be carried out inside Main DB / change over panel. The Neutral and Earth bus bars of the panel to be connected through a disconnectable link. CT's of Earth fault protective measures (if implemented) shall be installed in this location.

**Fig F-10**  
**Protective equipotential bonding and definitions**  
**(Clause F-8.2)**



**M** - exposed conductive part

**MET** - main earthing terminal

**C1** - building steel / reinforcement in concrete (extraneous conductive part)

**C2** - main metallic water pipe (extraneous conductive part)

**TT** - earth electrode (TT and IT systems)

**TN** - other means of earthing (TN systems) e.g. earthed point (neutral) of the source

**1** - protective earthing conductor (PE)

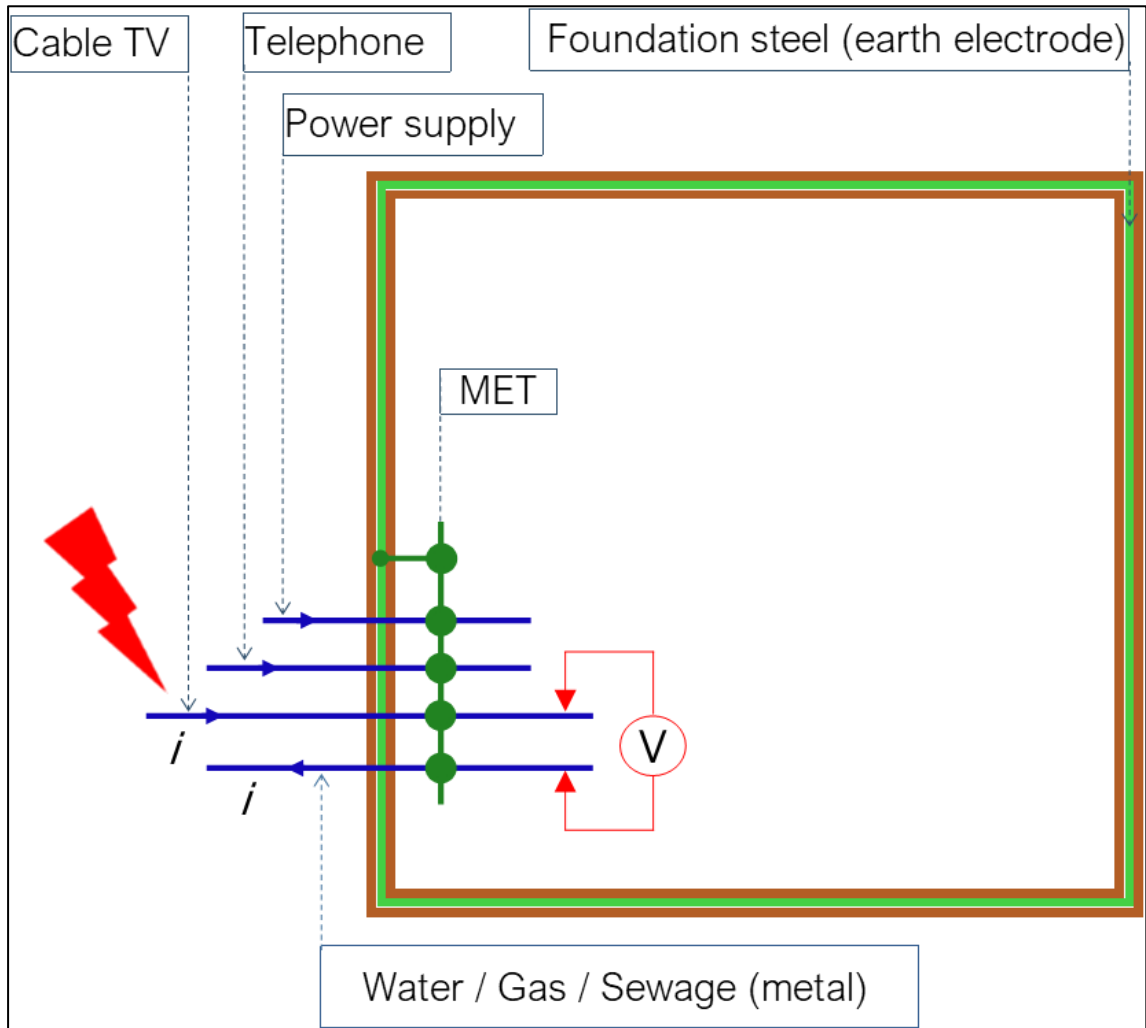
**2** - main equipotential bonding conductor

**3** - earthing conductor

**4** - supplementary equipotential bonding conductors (additional bonding if required)

**1,2,3,4** - are also called as protective conductors

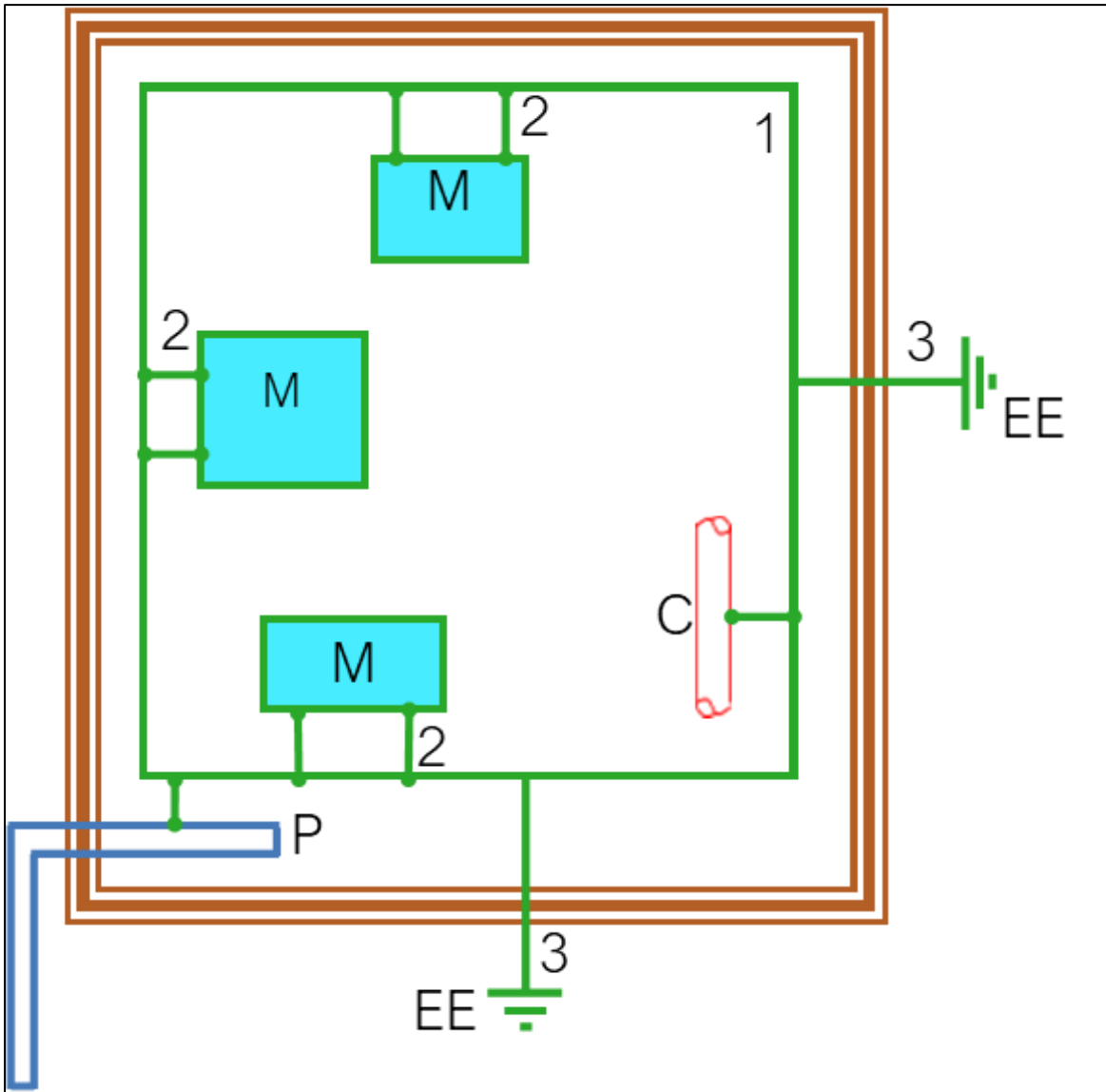
**Fig F-11**  
**(Clause F-8.2 & F-8.9.11)**  
**METAL PIPES AND THE METAL ARMOURING OF CABLES BONDED TO THE MAIN EARTHING TERMINAL AT THE ENTRANCE INTO THE BUILDING (reproduction of fig 42, IS732:2019)**



MET - Main Earth Terminal  
V = voltage created due to EMP  
(EMP: Electromagnetic pulse)

**Fig F-12**  
**(Clause F-8.8)**

**Earthing arrangement in an installation (reproduction of fig 31 of IS3043:2018)**

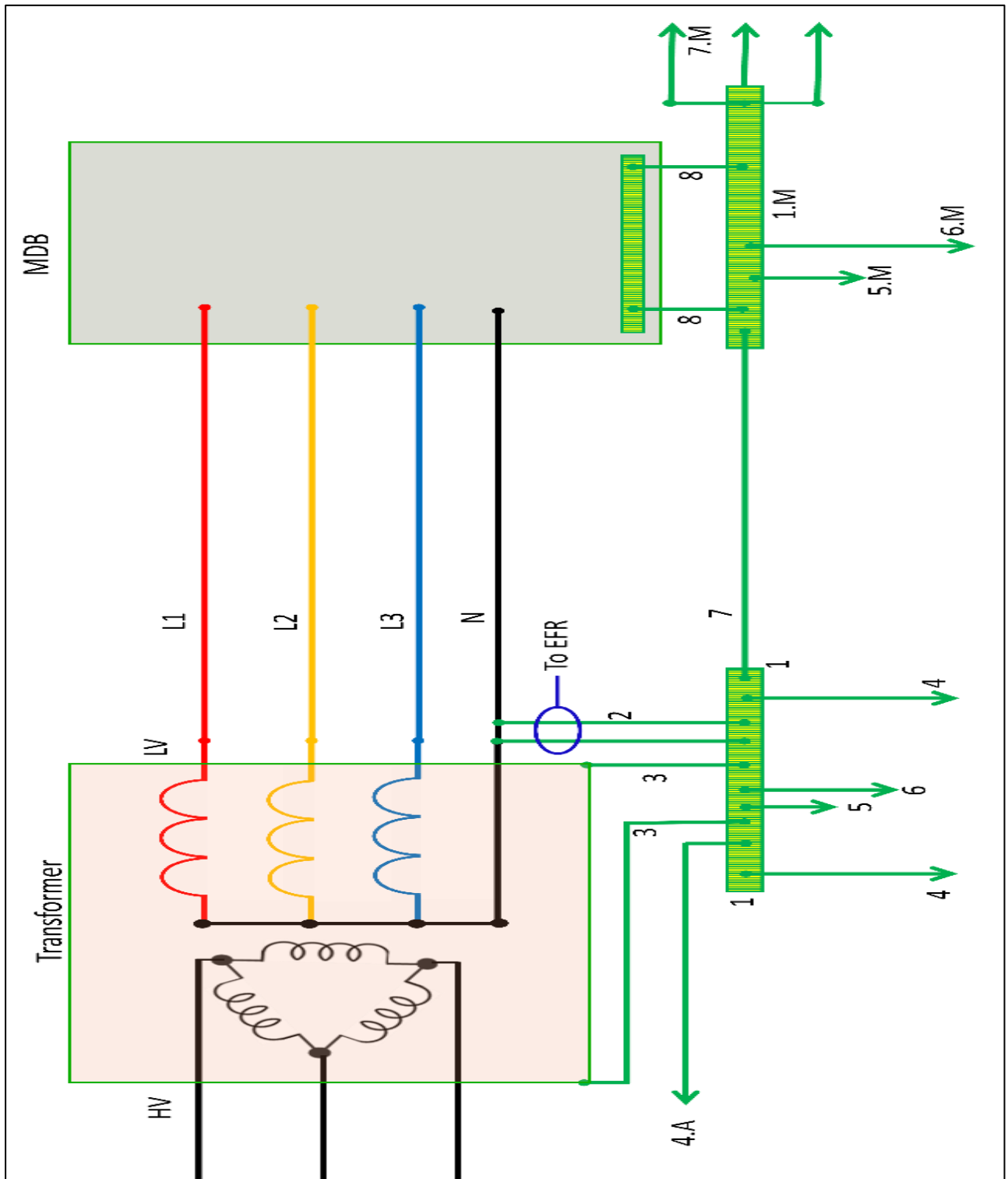


- M** = Exposed conductive parts
- P** = Incoming metallic service
- C** = Extraneous conductive parts
- EE** = Earth electrode
- 1** = Equipotential bonding conductor (**MET**)
- 2** = Protective earthing conductor (**PE**)<sup>\*</sup>
- 3** = Earthing conductor

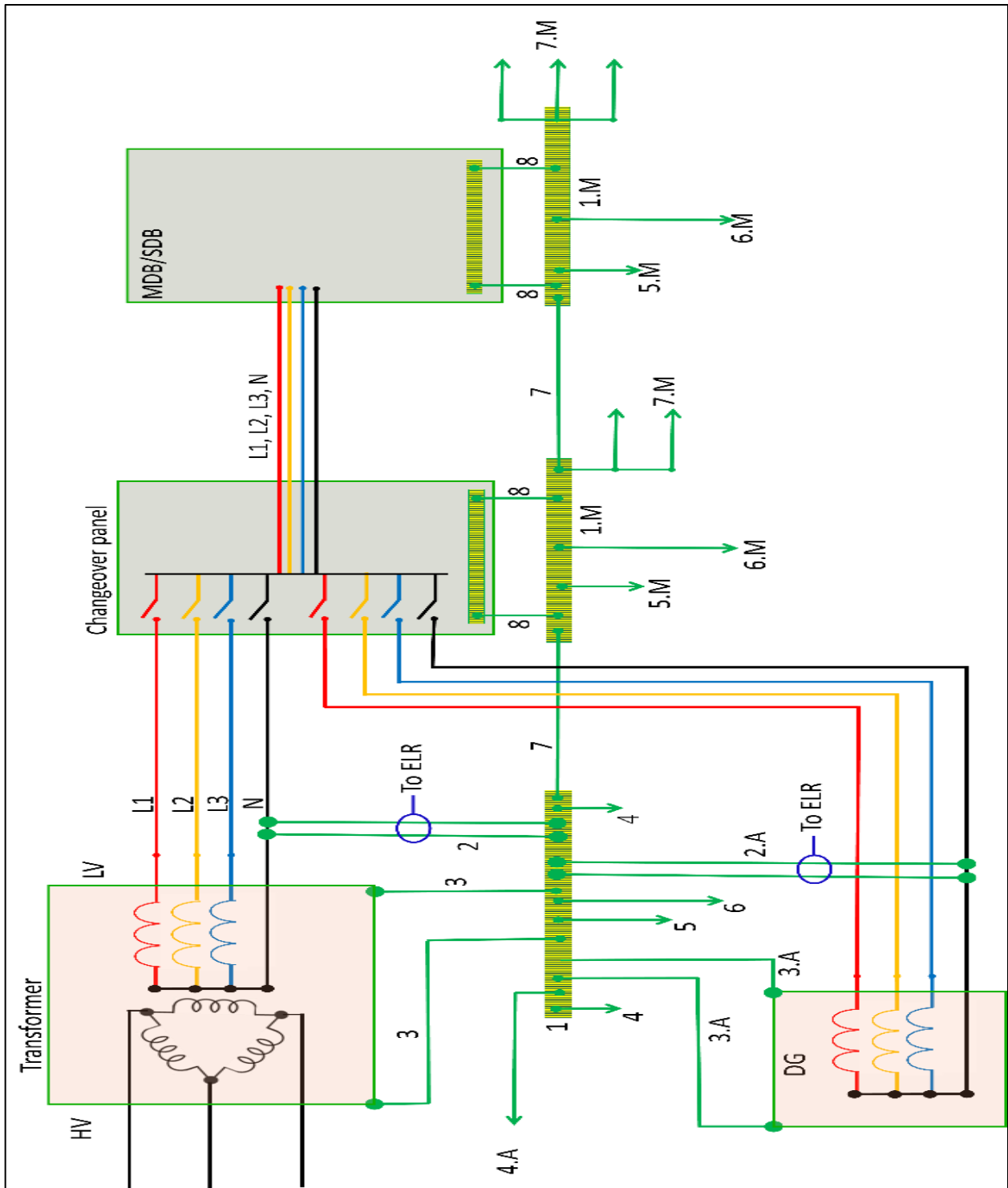
<sup>\*</sup> PE conductor in duplicate is mentioned in IS3043. IS732 doesn't recommend any duplicate connection. To avoid misinterpretations, the best way is to use one run of Equipotential bonding conductor (also called as MET) (of adequate size) along with cables. Connections from 3 phase equipment to this PE conductor can be in duplicate.

**Fig F-13A**  
**(Clause F-10.1)**

**Earthing of one transformer and associated equipment up to MDB. TN-S system**

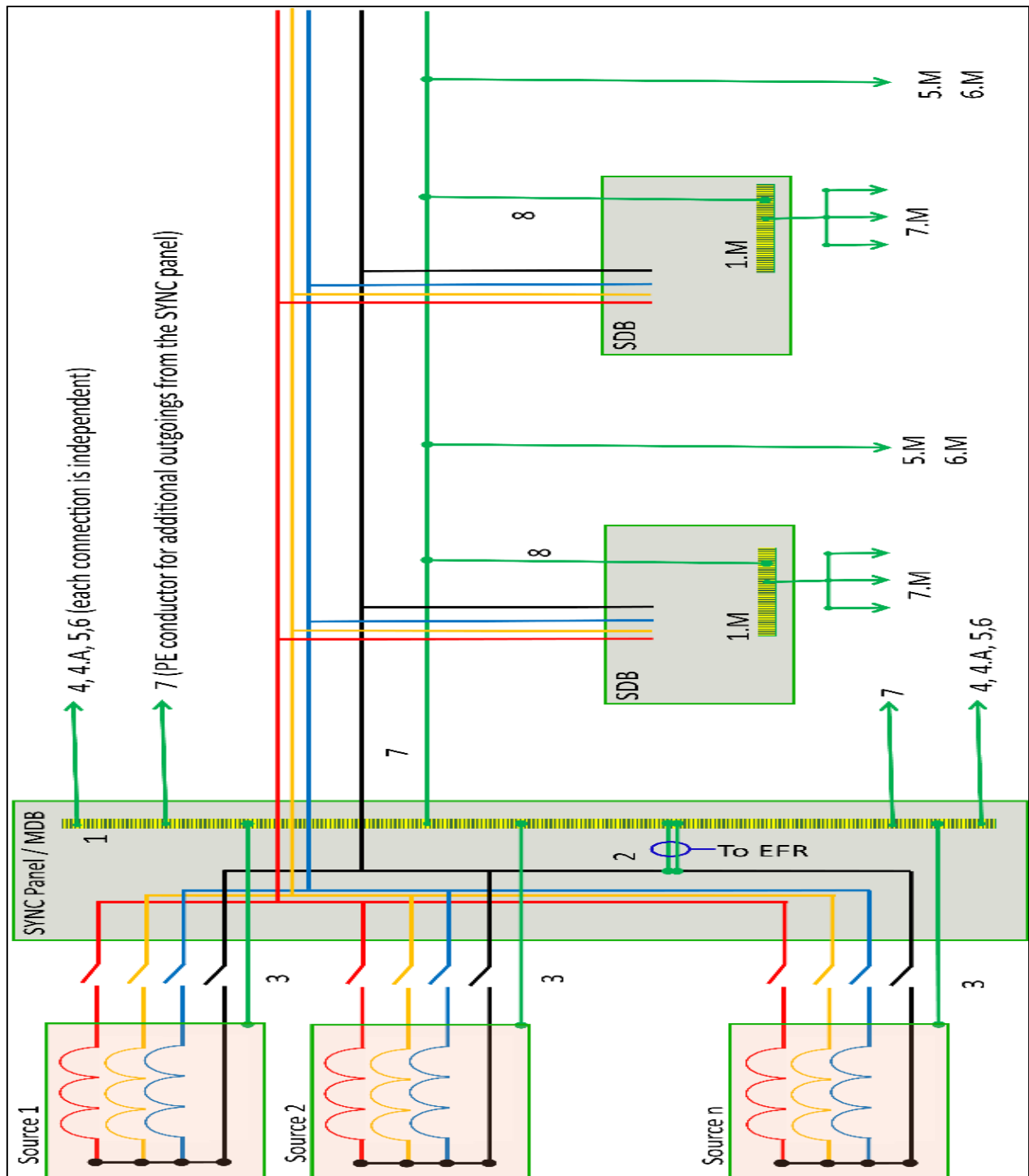


**Fig F-13B**  
**(Clause F-10.1)**  
**Earthing of one transformer and DG with Manual change, associated**  
**equipment up to MDB. TN-S system**



**Fig F-13C**  
(Clause F-10.1)

**Earthing of Earthing of several sources synchronized, associated equipment up to MDB. TN-S system**



**Key of figures F-13A to F-13C**

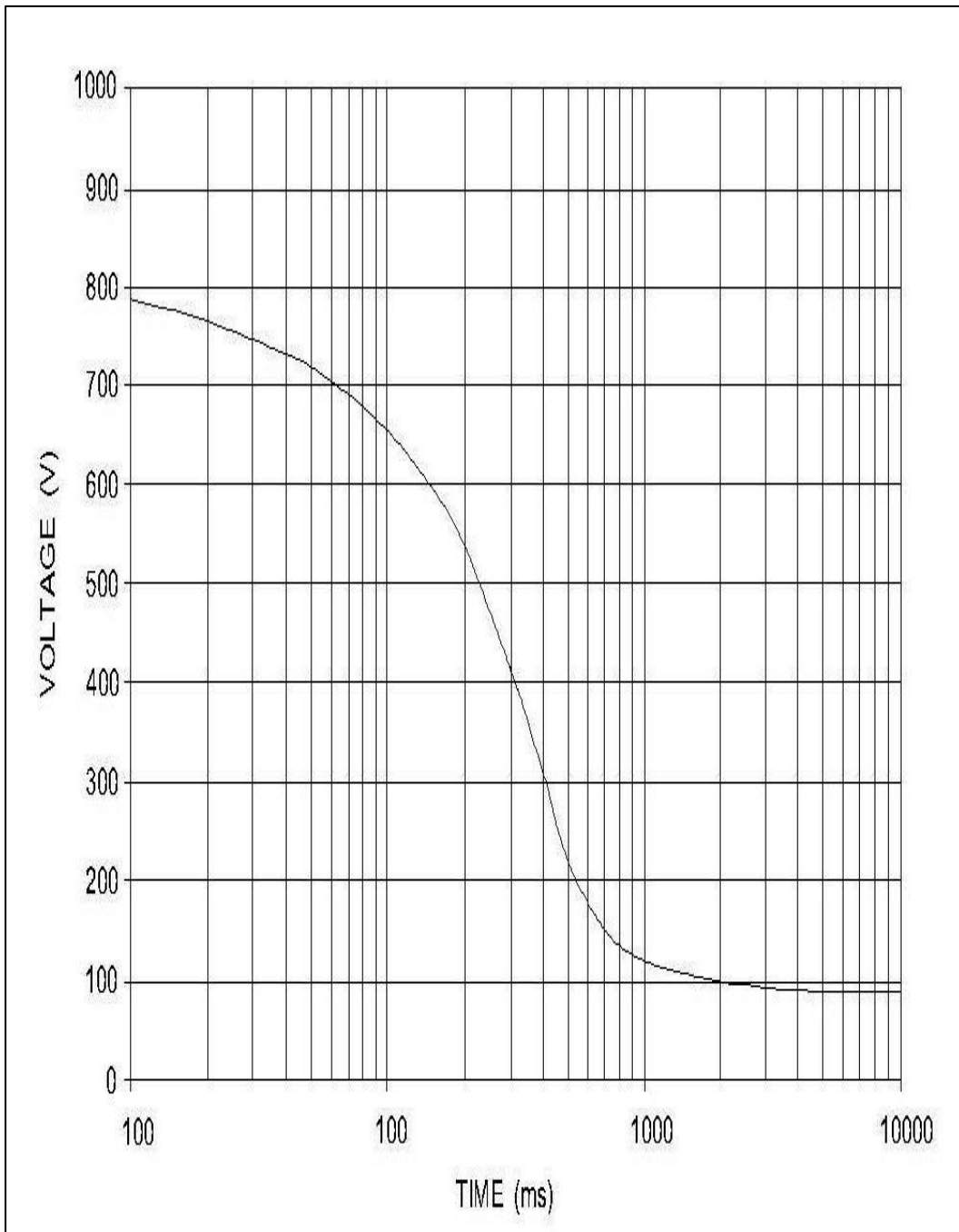
1	Main Earth Terminal (or main earth bar) (MET).
1.M	Main Earth Terminal inside premise and/or Sub MET near downstream DB's. Earth

	busbar inside DB's can be used for this purpose if they are sufficiently large for independent connection.
2	Neutral earthing of Transformer (2 connections) (in duplicate). Alternatively (neutral earthing) also can be made inside MDB by linking Neutral busbar and PE busbar. Ensure that Neutral earthing is carried out strictly only at one location to avoid neutral circulating current.
2.A	Neutral earthing of DG. (Connections in duplicate). This connection also can be located inside changeover panel.
3	Body earthing of Transformer (2 connections) (in duplicate).
3.A	Body earthing of Transformer (connections in duplicate).
4	Earthing conductor (2 connections) (in duplicate): Connection to earth electrode in soil (Earthing for HV side of transformer: The number and size of earth electrode shall be calculated based on the expected fault current at HV side, the soil resistivity and the surface area of earth electrode).
4.A	Earthing conductor: Connection to the armouring of incoming HV cable (if available).
5	Protective Bonding Conductor: Connections to other metallic objects in the area such as frame of structure, metal pipes (close by).
5.M	Protective Bonding Conductor (main or supplementary): Connections to extraneous conductive parts (such as aluminium frame of glass façade, structural steel metal pipes).
Note	HV Surge arrester earth busbar shall be connected to the nearest metal frame and to sl. No 5.
6	Connection to Lightning Protection of building (either to down conductor or to ring earth electrode - applicable if the transformer is inside or close to the building).
6.M	Connection to lightning protection of building (either to down conductor or to ring/foundation earth electrode).
Note	sl no.4,5,6, 5.M and 6.M can be an earth grid in soil / floor interconnecting structural columns in an industrial/commercial premise. For commercial / high rise buildings, this earth grid is a superimposed mesh conductor in RCC. This technique reduces fault loop impedance, improve shielding efficiency of building from lightning and other EMI).
7	Equipotential bonding conductor (also can be called as PE conductor). This conductor shall run as close as possible to the line conductors, if possible, through the same cable tray or busbar trunking system. Size to be calculated based on table 11.B of IS3043 and required fault loop impedance. Earth grid or similar arrangements are in addition to PE conductor and shall not be considered as an alternate to PE conductor.
7.M	Protective Earth Conductors running downstream from sub-MET (1.M). (Sizing to be calculated based on table 11.B IS3043 and required fault
8	Protective Earth conductor of 3 phase equipment (2 connections) (in duplicate).

<b>Important points to consider</b>	
a	All Connections shown in the picture are mandatory
b	No switching or protective devices shall be implemented in PE (or PEN/PEM) conductor.
c	Industrial Premise: sl no.4,5,6, 5.M and 6.M can be an earth grid in soil / floor interconnecting structural columns
d	Commercial / high rise buildings, 4,5,6,5.M and 6.M the grid (as above), is a superimposed mesh conductor in RCC. (For existing buildings, where this facility is not available, connection shall be made to ring earthing).
e	Foundation earthing is made by conductors of suitable size (other than galvanised steel and aluminium) superimposed inside concrete foundation
f	Electrical equipment (including power panels) inside industrial premise shall be connected to grid for efficient equipotential bonding
g	Galvanized steel in soil if directly connected to foundation earth / grid will be subjected to accelerated corrosion and shall be avoided.
h	Type 1 SPD (connection type 4+0 as per IS732) is necessary at MDB for completing equipotential bonding. Type 2 SPD is necessary at DB's where main or supplementary bonding is carried out.  Use an SPD without follow current and with inbuilt HRC fuse as back up protection.  Preferably use an SPD with 440-volt TOV withstand 120 minutes.
I	Functional earthing (also called as clean earthing) shall be connected to MET of the installation by functional earthing conductor (cream colour).
j	Earthing of equipment such as lift shall be made to protective earthing. (ref IS/ISO 8100-1 for more details)

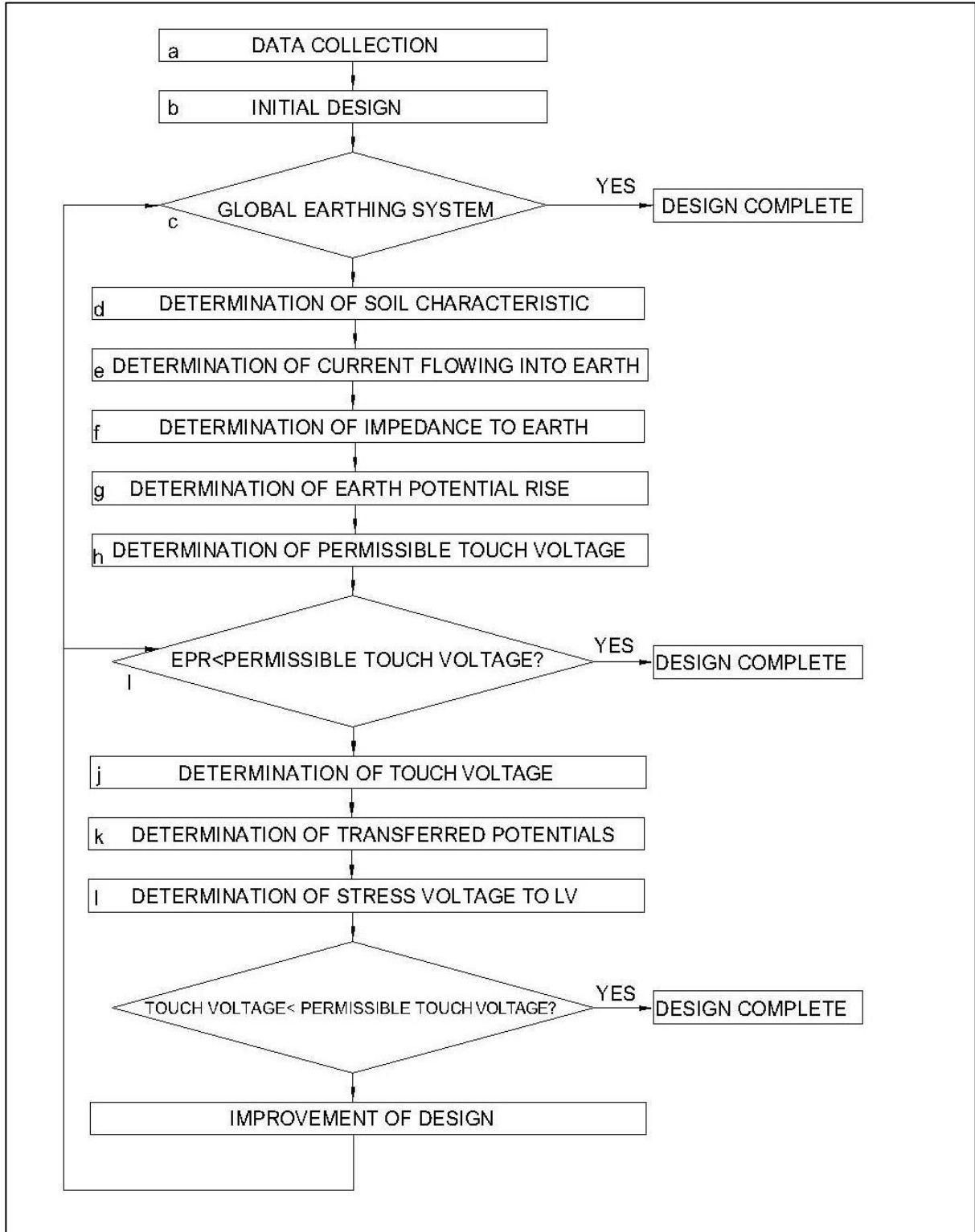


**FIG F-14**  
**(Clause F-10.2)**  
**PERMISSIBLE TOUCH VOLTAGE  $U_{TP}$  in an AC system**



**Fig F-15**  
**(Clause F-10.3)**

**EARTHING SYSTEM DESIGN FLOW CHART FOR VOLTAGE  
 EXCEEDING 1 Kv**



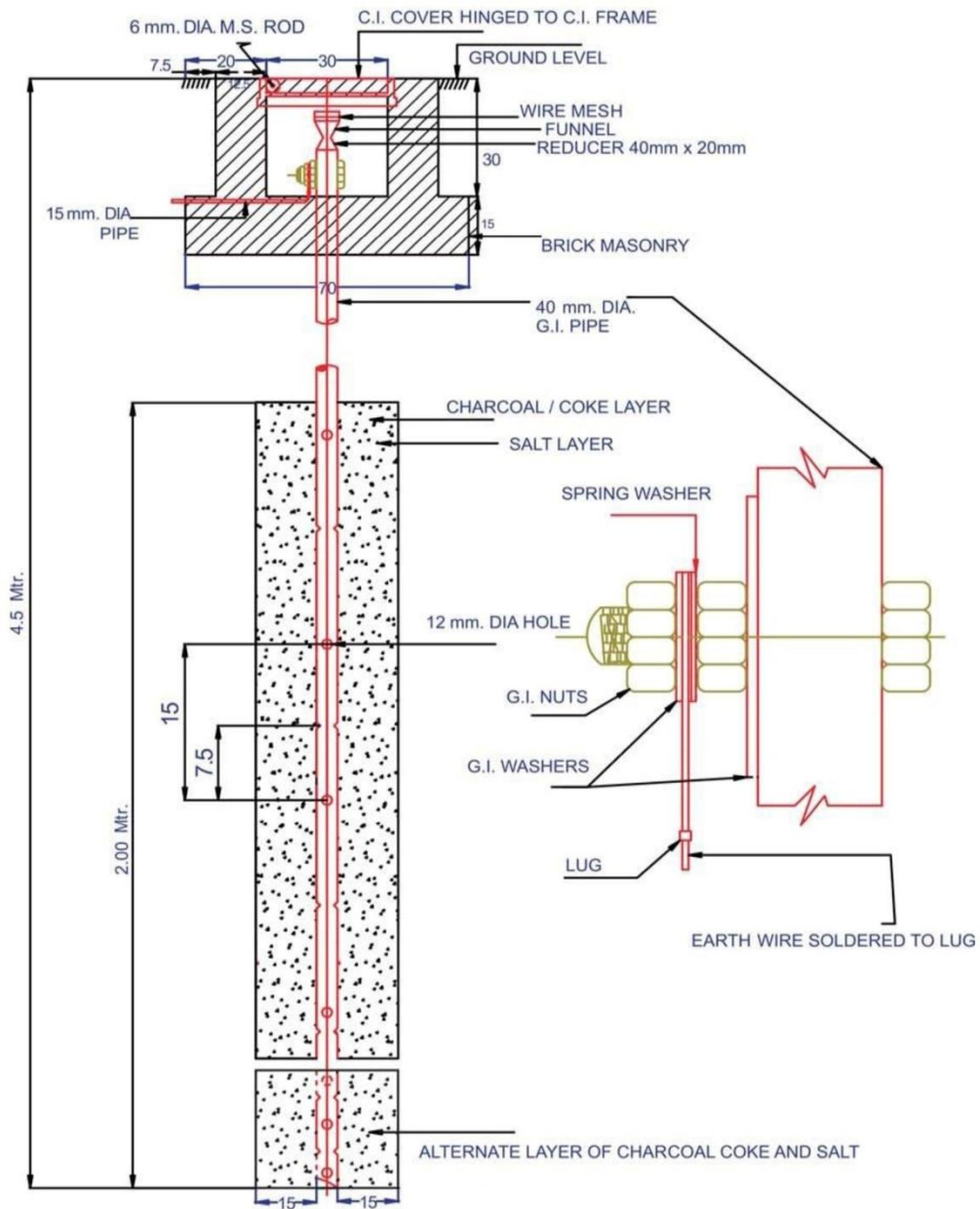


**Key:**

#	Name
C	Extraneous-Conductive-part
C1	Water pipe, metal from outside
C2	Waste water pipe, metal from outside
C3	Gas pipe with insulating insert, metal from outside
C4	Air-conditioning
C5	Heating system
C6	Water pipe, metal e.g in a bathroom
C7	Waste water pipe, metal e.g in a room
MDB	Main Distribution Board
DB	Distribution Board
MET	Main Earth Terminal
SEBT	Supplementary Equipotential Bonding terminal
T1	Concrete-embedded foundation earth electrode or soil-embedded foundation earth electrode
T2	Earth electrode for LPS if necessary
LPS	Lightning Protection system (if any)
PE	PE terminal(s) in the distribution board
PE/PEN	PE/PEN terminal(s) in the main distribution board
M	Exposed-conductive part
1	Protective Earthing conductor (PE)
1a	Protective Conductor, or PEN conductor, if any, from supplying network
2	Protective bonding conductor for connection to the main earthing terminal
3	Protective bonding conductor for supplementary bonding
4	Down conductor of a lightning protection system (LPS) if any
5	Earthing conductor

**FIG F-17**  
**(Clause F-8.9.2(b))**  
**Method of Pipe Earthing**

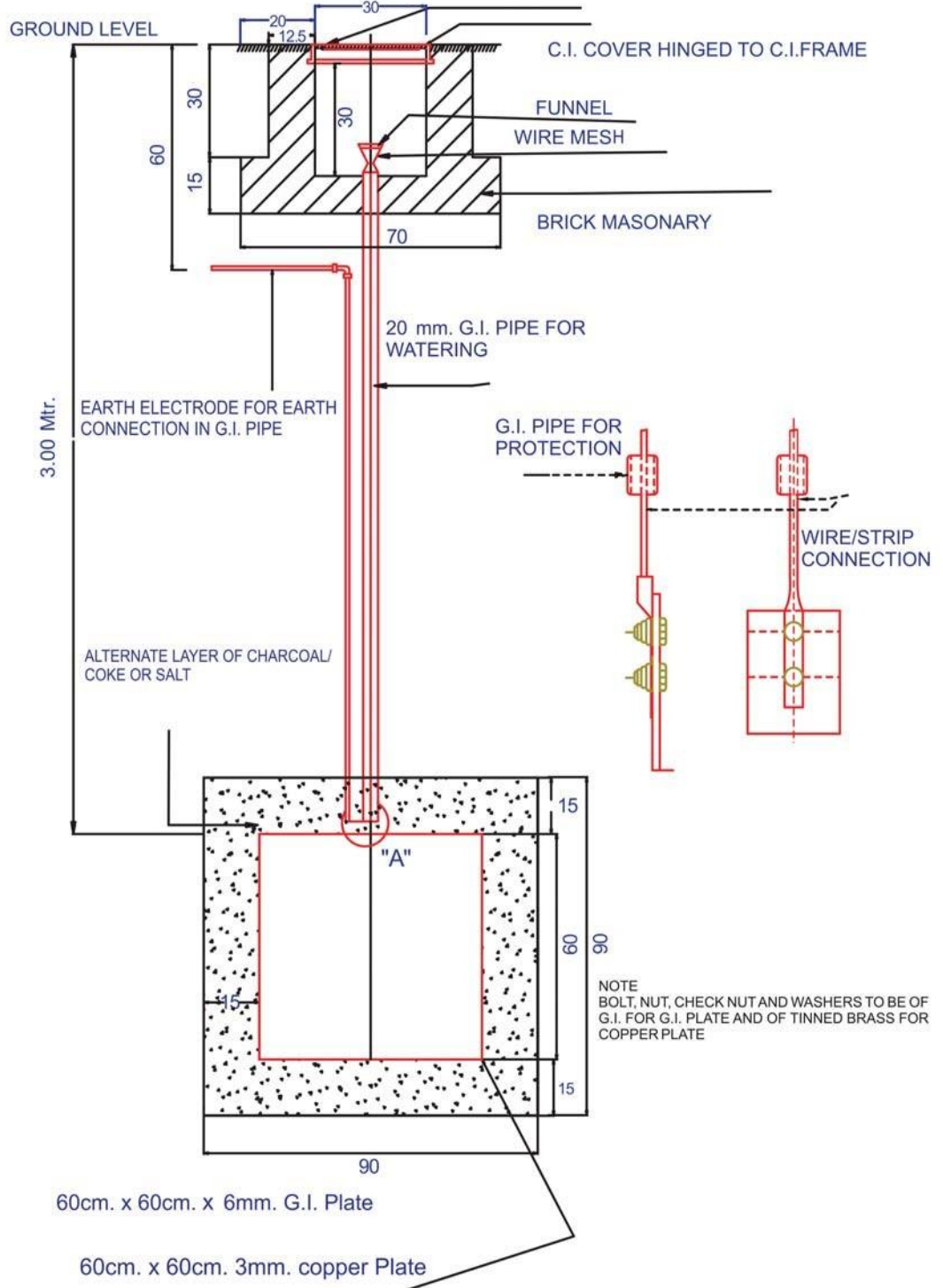
NOT TO SCALE



**NOTE:**  
 ALL DIMENSIONS ARE IN CM (OTHER DIMENSIONS SHOWN)

**FIG F-18**  
**(Clause F-8.9.2(c))**  
**Method of Plate Earthing**  
*[Clause 8.4.1.1(ii)]*

NOT TO SCALE



**Table F-1**  
**(Clause 5.4.1)**  
**Maximum Allowed Disconnection Times w.r.t Touch voltage**

Sl no.	Prospective Touch Voltage $U_c$ (V)	Condition 1 (DRY)			Condition 2 (WET)		
		$Z_1$ ( $\Omega$ )	$I$ (mA)	$t$ (s)	$Z_2$ ( $\Omega$ )	$I$ (mA)	$t$ (s)
(1)	(2)	(3)	(4)	(5)	(6)	(7)	(8)
i)	50	1725	29	5.000	925	54	0.470
ii)	110	1535	72	0.360	730	151	0.180
iii)	220	1375	160	0.170	575	383	0.035

**1** Dry or moist locations, dry skin and significant floor resistance.  
**2** Wet locations, wet skin and low floor resistance.

**Table F-2**  
**(Clause 5.4.2)**  
**Maximum Allowed Disconnection Times in final circuits recommended in IS732**

Type of system earthing	120 V < $U_0 \leq 230$ V	230 V < $U_0 \leq 400$ V
TN	0.4	0.2
TT	0.2	0.07

**Table F-3**  
**(Clause 7.1.4)**  
**Maximum Allowed Earth Fault Loop Impedance for MCB's**

Type and rating of MCB in Amps	6	10	16	20	25	32	40	50	63	80	100	125
Type B MCB	5.11	3.07	1.92	1.53	1.23	0.96	0.77	0.61	0.49	0.38	0.31	0.25
Type C MCB	2.56	1.53	0.96	0.77	0.61	0.48	0.38	0.31	0.24	0.19	0.15	0.12
Type D MCB	1.28	0.77	0.48	0.38	0.31	0.24	0.19	0.15	0.12	0.10	0.08	0.06

**Table F-4  
(Clause 8.4.2)**

**The materials and minimum sizes of Commonly Used Earth Electrodes,  
Embedded in Soil or Concrete Used to Prevent Corrosion  
and  
Provide Mechanical Strength.**

Sl no.	Material and Surface	Shape	Diameter mm	Cross Sectional Area mm <sup>2</sup>	Thickness mm	Weight of Coating g/m <sup>2</sup>	Thickness of Coating / Sheating µm	
(1)	(2)	(3)	(4)	(5)	(6)	(7)	(8)	
i)	Steel embedded in concrete (bare, hot galvanized or stainless)	Round wire	10					
ii)		Solid tape or strip		75	3			
iii)	Steel hot-dip galvanized <sup>c</sup>	Strip <sup>b</sup> or shaped strip/plate – solid plate – Lattice plate		90	3	500	63	
iv)		Round rod installed vertically	16			350	45	
v)		Round wire installed horizontally	10			350	45	
vi)		Pipe	25		2	350	45	
vii)		Stranded (embedded in concrete)			70			
viii)		Cross profile installed vertically			(290)	3		
ix)		Steel copper sheathed	Round rod installed vertically	(15)				2000
x)		Steel with electro-deposited copper coating	Round rod installed vertically	14				250 <sup>e</sup>
xi)	Round wire installed horizontally		(8)				70	

xii)		Strip installed horizontally		90	3		70
xiii)	Stainless Steel <sup>a</sup>	Strip <sup>b</sup> or shaped strip/plate		90	3		
xiv)		Round rod installed vertically	16				
xv)		Round wire installed horizontally	10				
xvi)		Pipe	25		2		
xvii)	copper	Strip		50	2		
xviii)		Round wire installed horizontally		(25) <sup>d</sup> 50			
xix)		Round rod installed vertically	(12) 15				
xx)		Stranded wire	1.7 for individual strands of wire	(25) <sup>d</sup> 50			
xxi)		Pipe <sup>e</sup>	20		2		
xxii)		Solid plate			(1.5) 2		
xxiii)		Lattice plate			2		

#### NOTES

**1** Values in bracket are applicable for protection against electric shock only, while values not in brackets are applicable for lightning protection and for protection against electric shock.

**2** Bare steel is not recommended in soil due to high corrosion.

**3** The behaviour of a galvanized layer on steel in concrete is very complicated and can under certain conditions cause damage to the concrete due to its dissimilar behaviour with steel in concrete. (also see IS 732).

**4** Indices used in the table:

a) Chromium  $\geq 16$  percent, nickel  $\geq 5$  percent, molybdenum  $\geq 2$  percent, carbon  $\leq 0.08$  percent.

b) As rolled strip or slit strip with rounded edges.

c) The coating shall be smooth, continuous and free from flux stains.

d) Where experience shows that the risk of corrosion and mechanical damage is extremely low, 16 mm<sup>2</sup> can be used.

e) This thickness is provided to withstand mechanical damage of copper coating during the installation process. It may be reduced to not less than 100  $\mu\text{m}$  where special precautions to avoid mechanical damage of copper during the installation process (for example, drilling holes or special protective tips) are taken according to the manufacturer's instruction.

**Table F-5  
(Clause 8.5.1)**

**Selection of protective Earthing conductor based on the size of line conductor**

Cross-sectional area of line conductor	Minimum cross-sectional area of the protective conductor (Cu - mm <sup>2</sup> )	
S (Cu) mm <sup>2</sup>	Protective conductor is of the same material as the line conductor	Protective conductor is not of the same material as the line conductor
$S \leq 16$	S	$K1 \div K2 \times S$
$16 < S \leq 35$	16 <sup>a</sup>	$K1 \div K2 \times 16$
$S > 35$	$S \div 2$ <sup>a</sup>	$K1 \div K2 \times S \div 2$

where

k1 is the value of k for the line conductor according to the materials of the conductor and insulation

k2 is the value of k for the protective conductor

**Table F-6  
(Clause 8.5.2)**

**Values of k for bare conductors where there is no risk of damage to any neighbouring material**

Conditions	Initial temperature °C	Material of conductor					
		Copper		Aluminium		Steel	
		Max. Final Temperature °C	k value	Max. Final Temperature °C	k value	Max. Final Temperature °C	k value
visible and in restricted areas	30	500	228	300	125	500	82
Normal Conditions	30	200	159	200	105	200	58
Fire risk	30	150	138	150	91	150	50

**Table F-7**  
**(Clause 8.5.2)**

**Values of k for bare protective conductors in contact with cable covering but not bunched with other cables**

cable covering	Temperature °C		Material of conductor		
	initial	final	Copper	Aluminium	Steel
			values of k		
Thermo plastic	30	200	159	105	58
PVC	30	150	138	91	50
Polyethylene (CSP)	30	220	166	110	60

e.g. of calculation in normal condition (200 °C)

- Material and Size of Phase conductor: Aluminium, 300 mm<sup>2</sup>, XLPE cable, 1 run.
- Material and condition of protective conductor: Galvanized steel, running along with cable tray
- K1= 105, K2 = 58 (note: K values are selected for normal condition, The maximum temperature withstand of XLPE cable is 250 °C) Size of PE conductor is  $105 \div 58 \times 300 \div 2 = 279 \text{ mm}^2$  , Say 300 mm<sup>2</sup> (e.g. 30 \* 6 mm GI strip)

## **APPENDIX G**

### **GUIDELINES FOR SELECTION AND APPLICATION OF RCCBs (RCDs)**

*[Clause 8.8]*

#### **G.0 General**

- G.0.1 IS 732: 2019 recognizes two forms of shock hazard, ‘Indirect contact’ and ‘Direct contact’. The objective is to achieve safety to personnel and property through the best possible means in the most economic manner.
- G.0.2 The most commonly used protective measure against indirect contact is termed “Protective equip-potential bonding and automatic disconnection of supply”. Irrespective of the type of protective device used, the aim is to prevent dangerous ‘touch voltages’ persisting on accessible conductive parts which become live under earth fault conditions. Use of RCCBs is only one of the means that would provide automatic disconnection of supply in the event of shock hazard. The use of RCCB is not considered, as a sole means of protection and it does not obviate the need to apply other protective measures. Some broad guidelines are provided in this Appendix on these issues.

#### **G.1 Residual Current Operated Circuit Breaker (RCCB)**

- G.1.1 In general, every circuit is provided with a means of over current protection. If the earth fault loop impedance is low enough to cause these devices to operate within the specified times, such devices can be relied upon to give the requisite automatic disconnection of supply. Where the earth fault loop impedance is too large, efforts are required to make it low enough. Guidelines are available in IS 3043: 2018.
- G.1.2 Fault voltage operated circuit breakers voltage operated ELCB are not preferred devices against shock protection. This Appendix covers only current-operated devices. These are of different types. The following are the two main types:
- (a) Residual current devices not dependent on-line voltage, and
  - (b) Residual current devices dependent on-line voltage.

#### **G.2 Choice of RCCBs**

- G.2.0 Where RCCBs are required to be used for affording shock protection; there are several broad parameters that are required to be carefully chosen. These are described in the following clauses.

##### **G.2.1 Location**

RCCB can be used as a protective measure to the entire installation, or part, or to an item of equipment. This is determined by the security of supply desired in certain parts of the same installation when RCCB operates. Where only one RCCB is being employed to protect the entire installation, it is necessary that it is located at the main distribution board, at the origin of the installation.

##### **G.2.2 Type of RCCB**

RCCBs are suitable in general for various applications. However, devices suitable for household applications are to be verified for additional requirements as given in this Appendix. RCCB that has its automatic opening intentionally delayed may be preferred under certain circumstances if coordination between two RCCB’s are necessary.

##### **G.2.2.1: Type of RCCB based on residual current with DC components**

There are four types of RCCB’s used in AC application depending upon the operating

characteristics in case of residual currents with DC components. They are

**RCD type AC:** An RCD for which tripping is ensured for residual sinusoidal alternating currents, whether suddenly applied or slowly rising.

**RCD type A:** An RCD for which tripping is ensured for type AC, for residual pulsating direct currents, and for residual pulsating direct currents superimposed on a smooth direct current of 0,006 A, with or without phase-angle control, independent of polarity, whether suddenly applied or slowly rising.

NOTE 1 Pluggable electrical equipment with a rated input  $\leq 4$  kVA are designed to have protective conductor current with a smooth superimposed DC current component limited to 6 mA.

NOTE 2 Operation in case of alternating current superimposed with smooth DC residual current is assumed to be covered by the test of pulsating DC superimposed with smooth DC residual current.

**RCD type F:** An RCD for which tripping is ensured for type A, for composite residual currents which may result from circuits supplied between phase and neutral or phase and earthed middle conductor; and for residual pulsating direct currents superimposed on smooth direct current of 0,01 A. The residual currents may be suddenly applied or slowly rising.

NOTE Operation in case of alternating current superimposed with smooth DC residual current is assumed to be covered by the test of pulsating DC superimposed with smooth DC residual current.


**RCD type B:** An RCD for which tripping is ensured as for type F and, in addition residual sinusoidal alternating currents up to 1 000 Hz, for residual alternating currents superimposed on a smooth direct current of 0,4 times the rated residual current ( $I_{\Delta n}$ ) or 10 mA whichever is the highest value, for residual pulsating direct currents superimposed on a smooth direct current of 0,4 times the rated residual current ( $I_{\Delta n}$ ) or 10 mA, whichever is the highest value, for residual direct currents which may result from rectifying circuits, (e.g. two-pulse bridge connection line to line for two-, three- and four-pole devices, three-pulse star connection or six-pulse bridge connection for three- and four-pole devices), for residual smooth direct currents.




The above specified residual currents may be suddenly applied or slowly increased independently of polarity.

### G.2.2.2: Selection of RCD's based on type of load

RCD's shall be selected and used based on the type of application / type of load as explained in Table G-1. Marking of different type of RCD's based on residual current and its application shall be as per table G-1

**Table G-1: Marking of RCD's based on residual current and its application**

Sl no	Type of RCCB	Type of Residual current	Symbol	Type of Application / load
1	Type AC	Alternating current only		Lights (other than LED lights), handheld or portable appliances

2	Type A	Full type AC features + Detection of pulsating current with DC components		Computer power supplies, LED lights, All appliances using SMPS (inverter air conditioner, inverter refrigerator etc).
3	Type F	Full type A features + Detection of high frequency currents up to 1 kHz		single phase VFD's
4	Type B	Full Type F features + Detection of smooth DC current		Three phase VFD's, SOLAR PV where simple separation between AC and DC are not maintained, (means no isolation transformer between Solar inverter and AC mains)

### G.2.3 Rated Current

The IS restricts the rated current of the device to an order of magnitude of 125 A. Use of RCCB in circuits of higher rated currents is not envisaged for the time being.

### G.2.4 Rated Tripping Current

(i) The preferred rated currents of RCCBs are 10, 30, 100 and 300 mA. RCCBs having maximum operating currents of 30 mA are intended to give protection against 'indirect contact'. It is essential that an RCCB is not used as a sole means for protection against "shock hazard".

(ii) The RCCB should be so chosen as to have the lowest suitable tripping current. Lower the tripping current, the greater is the degree of protection afforded. Nevertheless, it would introduce the possibility of nuisance tripping and may also become unnecessarily expensive. The minimum operating current will, therefore, have to be above any standing leakage that may be unavoidable in the installation.

#### G.2.4.1 Discrimination

When more than one RCCB is required to be used by grading the sensitivities, it is possible to achieve discrimination amongst RCCB in the same circuit. Discrimination may also be achieved by selectively employing devices having their tripping times intentionally delayed. According to time-delay (in presence of a residual current) RCCB's are classified as RCCB without time-delay (type for general use) & RCCB with time-delay (type S for selectivity)

## **G.2.5 Breaking Capacity**

(i) When using RCCBs, it is necessary to assess the prospective current value in the location where it is likely to be installed and ensure that where higher withstanding or breaking capacities are desirable, suitable back-up protection is available in the system. This could be by means of a fuse or another circuit breaker (MCB), which is in series with the RCCB. The over current/ short circuit protective device is then said to provide back-up protection for the RCCB. Alternately, RCCBs with integral over current/short circuit protection could be employed.

(ii) In practice, the functions of RCCB and that of the over current/ short circuit protective device in series may tend to overlap and under certain conditions both may attempt to clear the fault. This may occur, for example, when a severe earth fault produces a current of similar magnitude to that under short circuit conditions, or when an earth fault and short circuit occur simultaneously. Another possible cause is the inherent out of balance in the primary windings of the balance transformer causing the RCCB to trip. Care is, therefore, necessary to be exercised in ensuring that RCCB is coordinated with over current devices. The following parameters shall be selected based on the location of RCCB.

Rated making and breaking capacity ( $I_m$ ): The r.m.s. value of the a.c. component of prospective current, assigned by the manufacturer, which an RCCB can make, carry and break under specified conditions.

Rated residual making and breaking capacity ( $I_{\Delta m}$ ): The r.m.s. value of the a.c. component of residual prospective current, assigned by the manufacturer, which an RCCB can make, carry and break under specified conditions.

## **G.2.6 Neutral Grounding or Failure**

Use of RCCBs assumes adequate care in wiring and earthing design. Use of RCCB is not a sole means of affording shock protection. Attention should be given to protective equipotential bonding and choosing the right cross-sectional area of the conductors, especially the protective conductor. Different types of RCCBs in different circuits may react differently to the presence of a neutral to earth fault on the load side.

## **G.3 Guidelines for Specific Occupancies or Locations**

### **G.3.1 Household and Similar Installations**

The rated tripping current of RCCBs for use in household and similar installation shall not exceed 30 mA. Use of devices with intentional time delay is recommended only at the mains incoming in case additional RCCB's with same residual current is used downstream.

### **G.3.2 Locations containing Bath Tub/Shower Basin and Swimming Pools**

Where socket outlets and other appliances are to be protected by RCCB, the rated tripping current shall not exceed 30 mA.

**G.3.3** Where individual socket outlets are required to be protected by RCCB, the rated tripping current shall not exceed 30 mA.

### **G.3.4 Industrial Installations**

For industrial installations, use of RCCB would be dependent upon OCPD capable of offering fault protection. For example, use of a separate RCCB may not be necessary for installations equipped with protective devices with inbuilt releases initiating trip signals due to harmful earth leakages. Similarly, individual or group of motors otherwise adequately protected need not be provided additional protection through RCCBs.

### **G.3.5 Data Processing Installations/ Industrial Control/ Telecommunication Equipment**

Radio frequency interference suppression filters fitted to these equipment may produce high earth leakages. Failure of the protective earth connection may cause a dangerous touch voltage. Use of RCCBs under such circumstances should be carefully considered owing to their frequent tripping, besides capacitor charging currents at switching on shall have to be considered. Under such circumstances, where leakages exceed 10 mA, one of the three measures given below may be necessary:

- (a) Use TN-S system with high integrity protective earth circuits by robust or duplicate conductors,
- (b) Earth continuity monitoring, or provision for automatic disconnection when earth continuity fails, or
- (c) Use electrical separation for that circuit by using double wound transformers to enable localization of path of leakage and minimize the possibility of breakages.

**G.3.6** The presence of generating sets within an installation may change the conditions of application of RCCB. The contribution to the prospective short circuit current by the generating set should be taken into account.

### **G.3.7 Medical Establishment and Electrical Installations in Hazardous Locations**

The use of RCCB and their selection in such installations has to be carefully considered. Reference is invited to IS17512: 2021, “Requirements for Electrical Installations in Medical Locations.

### **G.4 Testing**

RCCB’s shall be tested with RCD tester, once in two years and the disconnection time shall be established.

## APPENDIX H

### PRINCIPLES OF PROTECTION OF BUILDING AGAINST LIGHTNING

*[Clause 9.2]*

**H.1:** This Appendix shall supplement the requirements in Chapter 9 of these specifications. There are no devices or methods capable of modifying the natural weather phenomena to the extent that they can prevent lightning discharges. Lightning flashes to, or nearby, structures (or lines connected to the structures) are hazardous to people, to the structures themselves, their contents and installations as well as to lines. This is why lightning protection measures are essential.

**H.2 Risk Assessment:**

The need for protection, the economic benefits of installing protection measures and the selection of adequate protection measures should be determined in terms of risk assessment. Before proceeding with the detailed design of a lightning protecting system, the following essential steps should be taken:

- a) Decide whether or not the structure needs protection and, if so, what are the special requirements (*see IS IEC 62305 – 2*)
- b) Modern buildings with electronic equipment need protection from radiated surges of Lightning. To achieve this structural steel of the building should form a part of lightning protection system (*see IS IEC 62305 – 3*). Ensure a close liaison between the architect, the builder, the lightning protective system engineer, and the appropriate authorities throughout the design stages.
- c) Include Lightning Protection measures in the structural drawing including foundation
- d) Agree the procedures for testing and future maintenance (*see IS IEC 62305 – 3 E.7*)

To reduce the loss due to lightning, protection measures may be required. Whether they are needed, and to what extent, should be determined by risk assessment. (*see IS IEC 62305 – 2*). The protection measures should ensure that the calculated risk is less than the tolerable risk explained in IS IEC 62305-2. Tolerable risk is maximum value of the risk which can be tolerated for the structure to be protected

**H.2.1 Typical values of tolerable risk (R<sub>T</sub>):**

Type of loss	Tolerable risk
Loss of human life or permanent injuries	$10^{-5}$ (One injury out of 100,000 Strikes)
Loss of service to the public	$10^{-3}$ (One service loss out of 1000 Strikes)
Loss of cultural heritage	$10^{-4}$ (One damage out of 10,000 Strikes)
Economic Loss	$10^{-3}$ (One failure out of 1,000 Strikes)

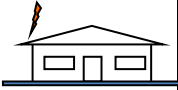


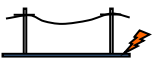
**H.2.2 Risk Analysis and Lightning Protection Level (LPL):**

Risk is analysed considering the following factors and protection is divided in to four protection levels (LPL 1 to 4)

- Source of Damage such as flashes to a structure, flashes near a structure, flashes to a line, flashes near a line.
- Type of damage - injury to living beings by electric shock, physical damage, failure of electrical and electronic systems

Type of Loss - loss of human life (including permanent injury), loss of service to the public, loss of cultural heritage, loss of economic value (structure, content, and loss of activity) See Table H-1.

**Table H-1**  
**Source and type of Damage and Type of loss**  
*(Clause H.2.2)*

		Structure		Service (Metal lines such as power, telephone etc.)	
Point of strike	Source of damage	Type of damage	Type of loss	Type of damage	Type of loss
	S1	D1 D2 D3	L1, L4 <sup>2)</sup> L1,L2, L3, L4 L1*, L2, L4	D2 D3	L`2, L`4 L`2, L`4
	S2	D3	L1 <sup>1)</sup> , L2, L4		
	S3	D1 D2 D3	L1, L4 <sup>2)</sup> L1, L2, L3, L4 L1 <sup>1)</sup> , L2, L4	D2 D3	L`2, L`4 L`2, L`4
	S4	D3	L1 <sup>1)</sup> , L2, L4	D3	L`2, L`4
1) Only for structures with risk of explosion, and for hospitals or other structures where failures of internal systems immediately endangers human life. 2) Only for properties where animals may be lost.					

### H.2.3 Risk :

Risk (**R**) is the value of a probable average annual loss. For each type of loss which may appear in a structure or in a service, the relevant risk shall be evaluated. The risk to be evaluated are as under for each source & type of damage

- R1: risk of loss of human life;
- R2: risk of loss of service to the public;
- R3: risk of loss of cultural heritage;
- R4: risk of loss of economic value.

Each risk component  $R_x = N_x \times P_x \times L_x$

Where  $N_x$  is the number of dangerous events per annum  
 $P_x$  is the probability of damage to a structure  
 $L_x$  is the consequent loss

Total risk R is the sum of various risk components. If  $R \leq R_T$ , lightning protection is not necessary.

( $R_T$  – Tolerable Risk)

Besides the need of lightning protection for a structure or for a service, it may be useful to ascertain the economic benefits of installing protection measures in order to reduce the

economic loss L4. The assessment of components of risk R4 for a structure allows the user to evaluate the cost of the economic loss with and without the adopted protection measures

#### H.2.4 Lightning Protection Level (LPL) :

Based on the risk assessment if protection is necessary, Lightning protection is divided into four levels (LPL 1 to 4) which helps in designing and implementing protection measures for an economical implementation. LPL 1 provides the maximum protection and expensive whereas LPL 4 provides the least protection and less expensive. As a thumb rule LPL recommended in Table H-2 can be used for typical buildings

**Table H-2: LPL recommended in NBC 2016 for typical buildings:  
(Clause H.2.4)**

Application	LPL*
Computer Data Centres, Military Applications, Nuclear Power Stations	1
EX-Zones in the industry and chemical sector	2
Schools, Banks, Residential Buildings, Hotels, Temple, Churches, Mosques	3

\*LPL – Lightning Protection Level

Protection measures are separate for External (to the structure) & Internal (electrical/electronic equipment). Both protection measures should complement each other

### H.3 External Lightning Protection

The external LPS is intended to intercept direct lightning flashes to the structure, including flashes to the side of the structure, and conduct the lightning current from the point of strike to ground. The external LPS is also intended to disperse this current into the earth without causing thermal or mechanical damage, or dangerous sparking which may trigger fire or Explosions. External Protection consists of Air Termination System, Down conductor System and Earthing System. All electrical and electronic equipment should maintain safety distance from lightning protection system to avoid flashover.

#### H.3.1 Air Termination System

The probability of penetration by a lightning current on a structure is considerably decreased by the presence of a properly designed air-termination system. Air-termination systems can be composed of any combination of the following elements:

- a) Vertical Rods (offers certain angle of protection)
- b) Catenary wires;
- c) Meshed / Grid conductors.

All types of air termination systems shall be positioned in accordance with **H.3.2**

The individual air-terminations rods should be connected together at roof level to ensure current division. Early Streamer Emission air terminals shall not be allowed. Any other kind of Air terminals if used, area within angle of protection as per table 4 of IS/IEC 62305-4 should only be considered as protected zone.

#### H.3.2 Positioning

Air-termination components installed on a structure shall be located at corners, exposed points and edges (especially on the upper level of any facades in accordance with one or more of the following methods:

- a) the protection angle method.
- b) the rolling sphere method.
- c) the mesh method.

The rolling sphere method is suitable in all cases {refer **5.2.2** of IS/IEC 62305-3}}.

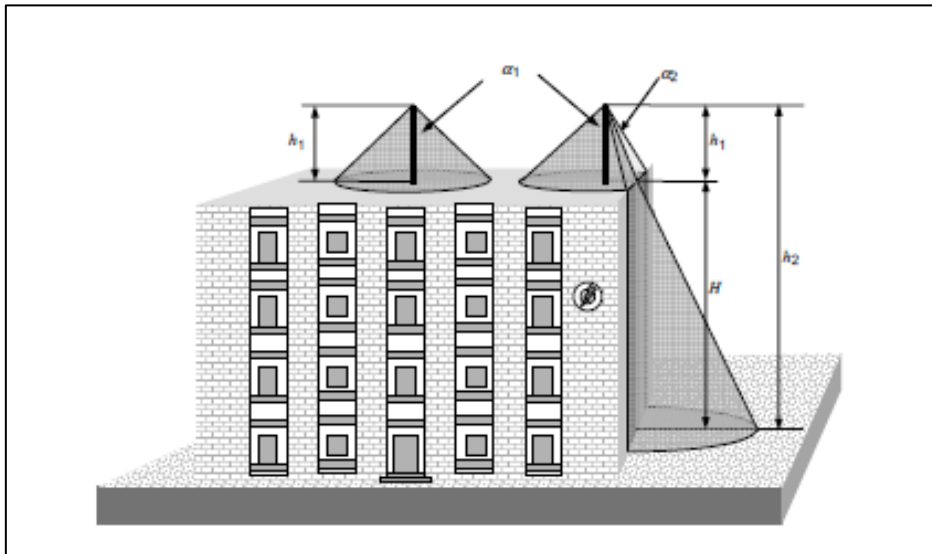
The protection angle method is suitable for simple shaped buildings but it is subject to limits of air-termination height indicated in Table H-3.

The mesh method is a suitable form of protection where plane/pitch roof surfaces are to be protected. See Fig.H-1(A to E).

**Table H-3**  
**Maximum values of mesh size and protection angle corresponding to the class of LPS**  
*(Clause H.3.2)*

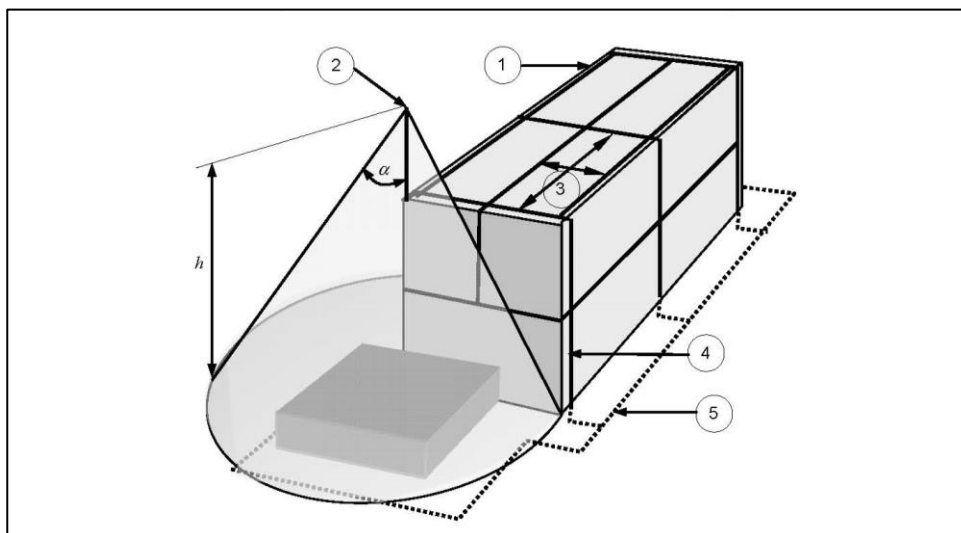
Class of LPS	Mesh size in meters	Protection angle w.r.t height				
		10 meter	20 meter	30 meter	45 meter	60 meter
1	5 x 5	45	23	Cannot be used		
2	10 x 10	54	38	23	Cannot be used	
3	15 x 15	62	48	36	23	Cannot be used
4	20 x 20	65	54	45	34	23

**Fig H-1A**  
**PROTECTIVE ANGLE METHOD OF AIR TERMINATION DESIGN**  
**FOR DIFFERENT HEIGHTS**



- H      Height of the building over the ground reference plane
- h1     Physical height of an air termination rod
- h2     h1 + H – Height of the air termination rod over the ground
- $\alpha_1$     The protection angle corresponding to the air termination height  $h = h_1$
- $\alpha_2$     The protection angle corresponding to the height  $h_2$

**Fig H-1B**  
**DESIGN OF AN LPS AIR-TERMINATION ACCORDING TO THE**  
**PROTECTION ANGLE METHOD, MESH METHOD AND GENERAL**  
**ARRANGEMENT OF AIR-TERMINATION ELEMENTS**

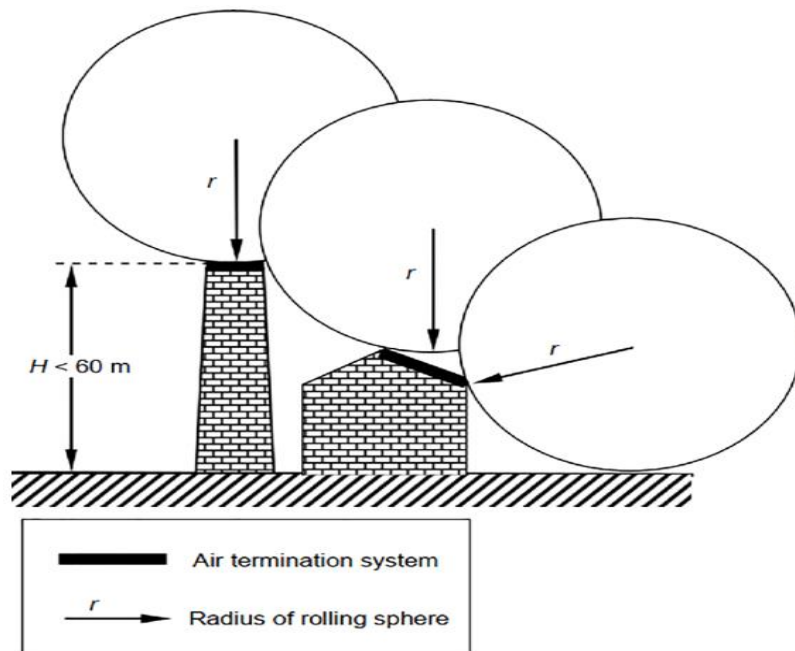


Key:

- 1. Air-termination conductor (also called as mesh / faraday cage ) see table H-4 for mesh size
- 2. Air-termination rod
- 3. Mesh size
- 4. Down-conductor
- 5. Earthing system with ring conductor
- h. Height of air terminal above ground level
- $\alpha$ . Protection angle

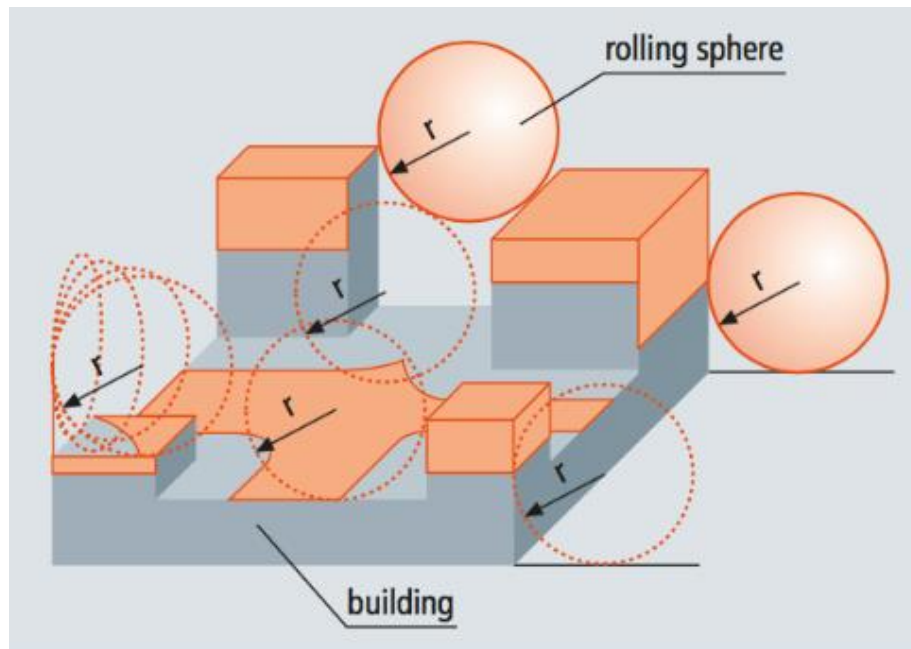
**FIG. H-1C**

**DESIGN OF AIR TERMINATION SYSTEM ACCORDING TO THE ROLLING SPHERE METHOD**



**FIG. H.1D**

**DESIGN OF AIR-TERMINATION SYSTEM ACCORDING TO ROLLING SPHERE METHOD FOR COMPLEX STRUCTURE**

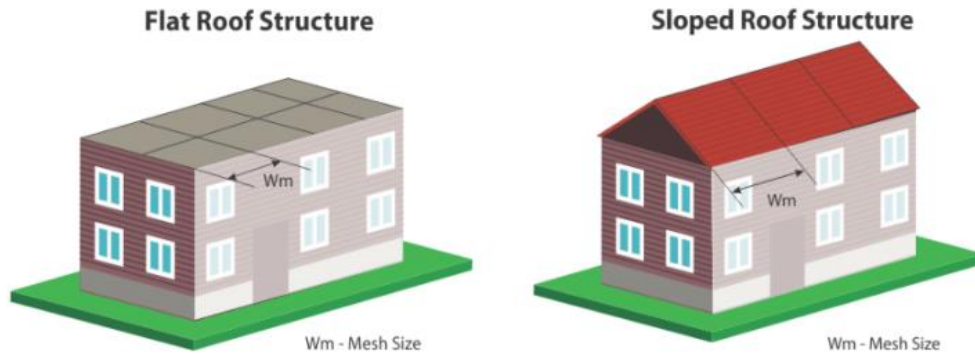


Key:

1. Shaded areas are exposed to lightning interception and need protection
2. Mast on the structure
3. Radius of rolling sphere

**FIG. H.1E**

**DESIGN OF AIR-TERMINATION SYSTEM ACCORDING TO MESH METHOD**



**H.3.3 :** Roof mounted electrical/electronic equipment (eg. chillers, antennas, cameras, bill boards, aviation lamps etc.) need vertical air termination to avoid direct flashover. All parts of lightning protection should maintain safety distance from these electrical / electronic equipment. Power and data connection to these equipment should have proper SPD's to avoid failures. Overhead cables such as cable TV lines from one building to the other should be avoided.

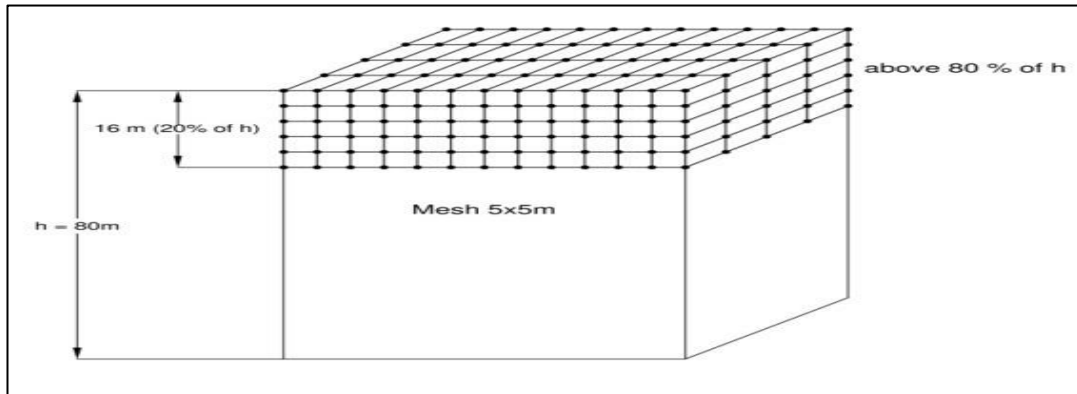
**H.3.4 :** Air terminal like early streamer, dissipation system, control Streamer emitter are not conforming to Indian standards and shall not be used.

**H.3.6 : Structures 60 meter in height or more**

On structures taller than 60 m, flashes to the side may occur, especially to points, corners and edges of surfaces. In general the risk due to these flashes is low, but electrical and electronic equipment on walls outside structures may be destroyed even by lightning flashes with low current peak values.

An air-termination system shall be installed to protect the upper part of tall structures (i.e. typically the topmost 20 % of the height of the structure as far as this part exceeds 60 m in height) and the equipment installed on it. The rules for positioning the air-termination systems on these upper parts of a structure shall meet at least the requirements for LPL IV with emphasis on the location of air-termination devices on corners, edges, and significant protrusions (such as balconies, viewing platforms, etc.). See fig H-2.

**FIG H-2**  
**AIR TERMINATION TO AVOID SIDE FLASH FOR A BUILDING WITH MORE THAN 60 METER HEIGHT**



**Note:** Required only if electronic components are installed.

LPL 1 to 4 can be considered depending upon the Risk involved

### H.3.7 Buildings with roof top Solar PV and Water Heaters

Vertical air terminals are required for protecting roof mounted installations such as solar PV, water heaters, chillers as well as Water tanks. Protection angle to be considered is as per table H-3. Vertical air terminals need to be connected to the air termination mesh / down conductors. Metal support structure of these installations must be bonded to the air termination mesh / down conductors. Type 1 or Type 2 SPD's should be installed in the electrical lines to protect the installations inside the building typically DC SPD for SOLAR PV output (at inverter or junction box level) and AC SPD for inverter output and mains input.

### H.3.8 Buildings with Rooftop Telecom Towers

The metallic tower itself will act as air termination. Antennas mounted in these towers (If antenna mounted below to the top of tower by more than one metre then no air terminal is required on top of tower) need individual air terminals connected to the main structure. The main structure must be connected to the air-termination conductors for the balance of the building if available. Two separate down conductors with a size of minimum  $150\text{mm}^2$  are to be used in addition to regular down conductors to make the bonding between tower and ring earthing.

Every power, coaxial, data and other metallic lines connected between the telecom installation and the other parts of the building must be protected with SPD's.

## H.4 Down Conductor System

In order to reduce the probability of damage due to lightning current flowing in the LPS, the down-conductors shall be arranged in such a way that from the point of strike to earth:

- a) several parallel current paths exist.
- b) the length of the current paths is kept to a minimum.
- c) equipotential bonding to conducting parts of the structure is performed.

**H.4.1** Typical values of the distance between down-conductors are in table H-4. These values can be used for horizontal ring conductors installed for a tall building more than 60 meter height.

**Table H-4: MINIMUM DISTANCE BETWEEN DOWN CONDUCTORS  
(Clause H.4.1)**

Class of LPS	Distance in meters
1	10
2	10
3	15
4	20

**H.4.2** Down-conductors shall be installed so that, as far as practicable, they form a direct continuation of the air-termination conductors. It shall be installed straight and vertical such that they provide the shortest and most direct path to earth. The formation of sharp bends and loops shall be avoided. Every down conductor should be connected to a type B ring/foundation earthing. Connection of Down conductor to a type A earthing is allowed only in case of space constraints or existing buildings where installation is difficult.

**H.4.3** While routing the down conductors, separation distance need to be calculated based on clause H.6 and maintained from live parts / services.

**H.4.4** Lateral connection of down-conductors at ground level and every 10 m to 20 m of height as a ring conductor is considered to be good practice. The installation of as many down-conductors as possible, at equal spacing around the perimeter interconnected by ring conductors, reduces the probability of dangerous sparking and facilitates the protection of internal installations. This condition is fulfilled in metal framework structures and in reinforced concrete structures in which the interconnected steel is electrically continuous.

**H.4.5** Routing of down conductors (insulated or uninsulated) through electrical and other service shafts are not allowed as it can create fire and explosion during lightning.

**H.4.6** Single run of down conductor using high voltage insulated cable from air terminal to earthing are not conforming to IS/IEC 62305. Insulated down conductors can only avoid separation distance to live parts of the building. In such case separation distance should be calculated based on clause H.6 and recorded to ensure safety.

**H.4.7** The down conductor shall be supported on structure like column at every 1 meter using suitable clamps or connectors. The clamps or connectors shall be tested as per IEC 62561.

**H.4.8** Special cables tested for lightning current and with high voltage insulation can be used wherever necessary to avoid flashovers in case separation distance is not possible to be maintained.

**H.5 Earth Termination System**

When dealing with the dispersion of the lightning current (high frequency behaviour) into the ground, whilst minimizing any potentially dangerous over voltages, the shape and dimensions of the earth-termination system are the important criteria. In general, a low earthing resistance (if possible lower than 10 ohms when measured at low frequency) is recommended. From the viewpoint of lightning protection, a single integrated structure earth-termination system is preferable and is suitable for all purposes (i.e. lightning protection, power systems and

telecommunication systems). Earthing systems are classified into TYPE A and TYPE B earthing

Type A earth termination comprising of vertical / horizontal conductor and Type B earth termination comprising of Ring Earthing / Foundation earthing. The earth termination system shall be used satisfying the requirements of IS IEC 62305 3&4.

**H.5.1** Type A Earthing Length of the earth electrode (See table H-5) depends on the soil resistivity and LPL. Each down conductor shall be connected to an earth electrode.

**Table H-5**  
**Minimum Length of vertical earth electrode**  
**(Clause H.5.1)**

Class of LPS	Typical Length of each vertical earth electrode based on Soil resistivity			
	Up to 500 Ω M	1000 Ω M	2000 Ω M	3000 Ω M
1	2.5 meter	10 meters	25 meters	40 meter
2	2.5 meter	5 meter	15 meters	22 meter
3	2.5 meter	2.5 meter	2.5 meter	2.5 meter
4	2.5 meter	2.5 meter	2.5 meter	2.5 meter

**H.5.2 Type B earthing:** This type of arrangement comprises either a ring conductor external to the structure to be protected, in contact with the soil for at least 80 % of its total length, or a foundation earth electrode. Such earth electrodes may also be meshed. For more information ref clause 5.4 of IS/IEC 62305.

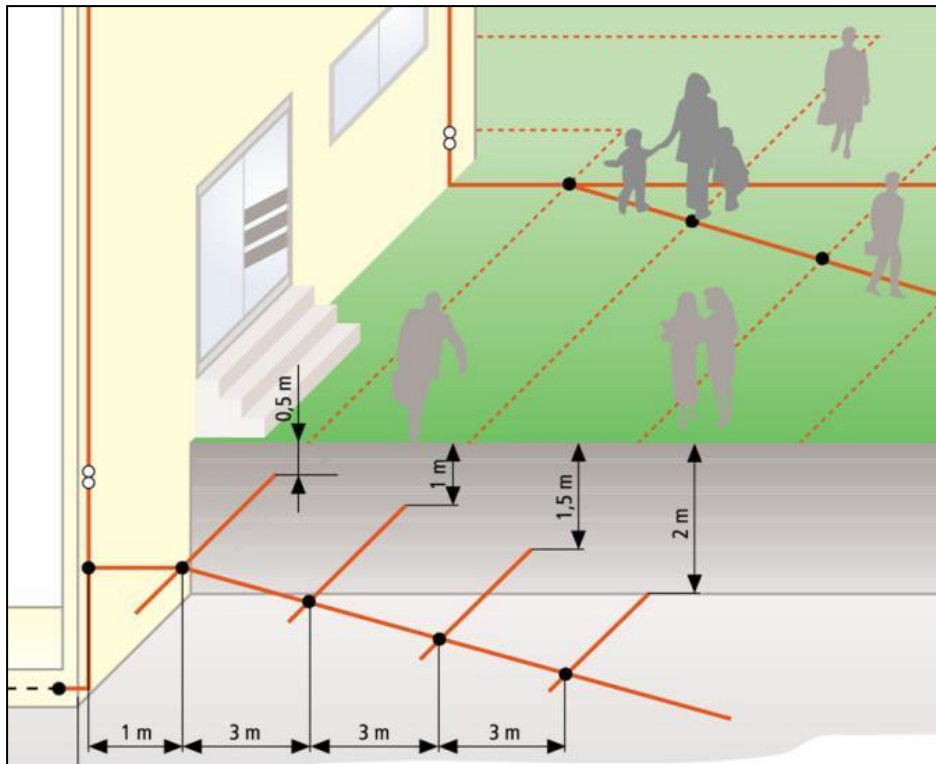
**H.5.3** In structures where only electrical systems are provided, a type A earthing arrangement may be used, but a type B earthing arrangement is preferable. In structures with electronic systems such as computers, UPS, BMS system, security cameras etc, a type B earthing arrangement is recommended.

**H.5.4** For buildings without steel reinforced foundation (brickwork / Stones) a type B earth-termination as a Ring Earthing shall be installed.

**H.5.5 Protection of People outside building**

Where large numbers of people frequently assemble in an area adjacent to the structure to be Protected, further potential control for such areas should be provided. More ring earth electrodes should be installed at distances of approximately 3 meter from the first and subsequent ring conductors. Ring electrodes further from the structure should be installed more deeply below the surface i.e. those at 4 meter from the structure at a depth of 1 meter, those at 7 meter from the structure at a depth of 1.5 meter and those at 10 meter from the structure at a depth of 2 meter as shown in figure H-3. These ring earth electrodes should be connected to the first ring conductor by means of radial conductors. The earth grid thus formed will reduce the step potential so that people in this area are safe.

**FIG. H-3**  
**Mesh / Ring Earthing – reduction of step potential**



**H.5.6** For buildings integrating structural steel as down conductor and earth termination, earth resistivity measurements are not required. Proper drawings should be made based on the actual installation and submitted to authorities if necessary.

**H.6 Separation distance**

**H.6.1 Electrical insulation of the external LPS**

Electrical insulation between the air-termination or the down-conductor and the structural metal parts, the metal installations and the internal systems can be achieved by providing a separation distance, *s*, between the parts. The general equation for the calculation of *s* is given by:

$$s = \frac{k_i}{k_m} \times k_c \times l \quad (\text{m})$$

where

*k<sub>i</sub>* depends on the selected class of LPS (see Table H-6);

*k<sub>m</sub>* depends on the electrical insulation material (see Table H-7);

*k<sub>c</sub>* depends on the (partial) lightning current flowing on the air-termination and the down conductor.

*l* is the length, in metres, along the air-termination and the down-conductor from the point, where the separation distance is to be considered, to the nearest equipotential bonding point or the earth termination.

**Table H-6**  
**Isolated external LPS – Values of coefficient *K<sub>i</sub>***

Class of LPS	<i>k<sub>i</sub></i>
I	0,08
II	0,06
III and IV	0,04

**Table H-7****Isolated external LPS – Values of coefficient  $K_m$** 

Material	$k_m$
Air	1
Concrete, bricks, wood	0,5
NOTE 1 When there are several insulating materials in series, it is a good practice to use the lower value for $k_m$ .	
NOTE 2 In using other insulating materials, construction guidance and the value of $k_m$ should be provided by the manufacturer.	

- H.6.2** In the case of the lines or external conductive parts entering the structure, it is always necessary to ensure lightning equipotential bonding (by direct connection or connection by SPD) at their point of entry into the structure.
- H.6.3** In structures with metallic or electrically continuous connected reinforced concrete framework a separation distance is not required.
- H.6.4** The coefficient  $k_c$  of the lightning current amongst the air-terminations/down-conductors depends on the class of LPS, on the overall number  $n$ , on the position of the down conductors, on the interconnecting ring conductors and on the type of earth-termination system. The necessary separation distance depends on the voltage drop of the shortest path from the point where the separation distance is to be considered, to the ground electrode or the nearest equipotential bonding point.
- H.6.5**  $k_c$  (Table H-8) depends on the (partial) lightning current flowing on the down-conductor arrangement
- H.6.6**  $l$  is the vertical length, in metres, along the down-conductor, from the point where the separation distance is to be considered, to the nearest equipotential bonding point.

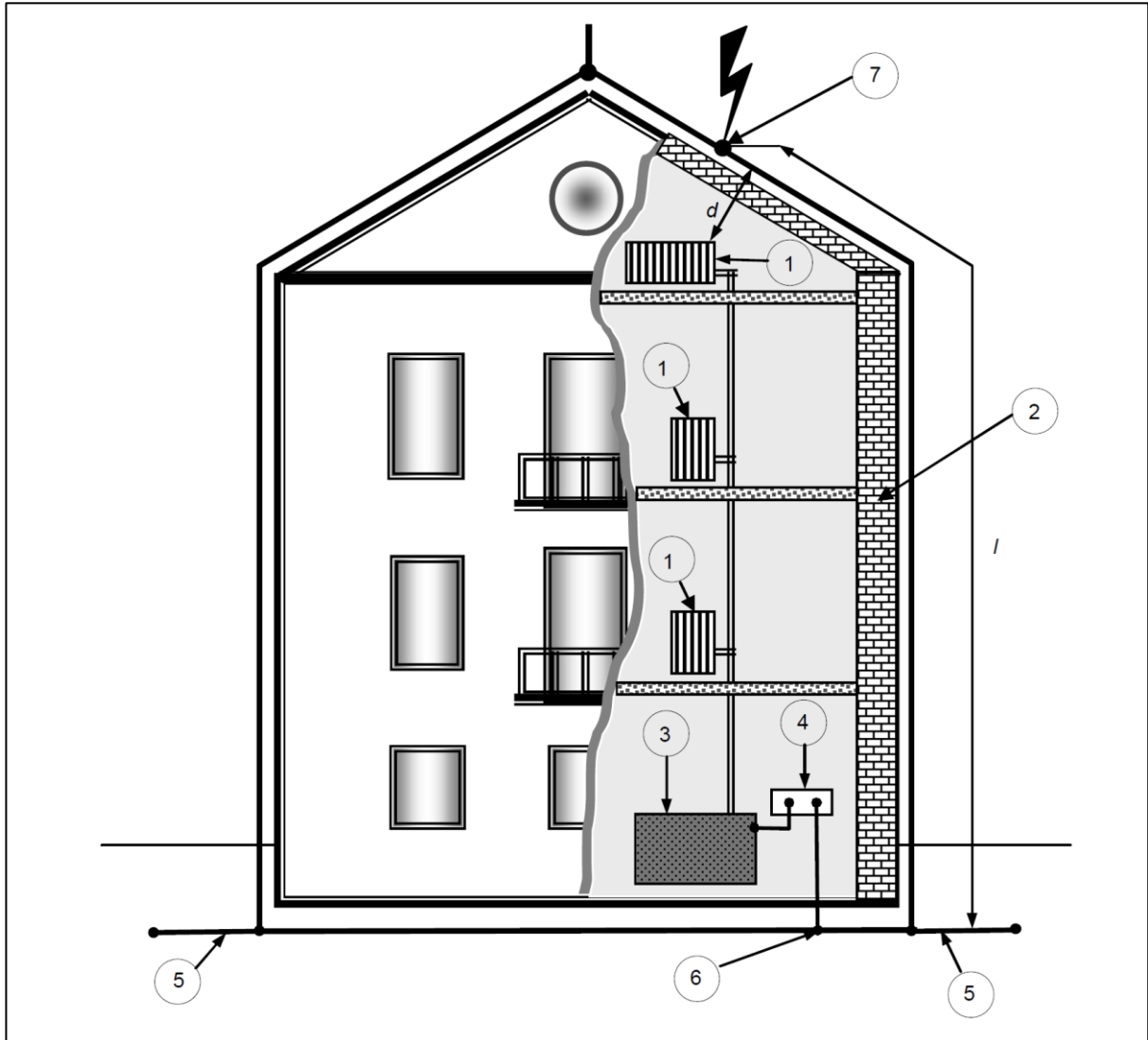
**Table H-8: Isolated external LPS – Values of coefficient  $K_c$** 

Number of down-conductors $n$	$k_c$
1 (only in case of an isolated LPS)	1
2	0,66
3 and more	0,44
NOTE Values of Table 12 apply for all type B earthing arrangements and for type A earthing arrangements, provided that the earth resistance of neighbouring earth electrodes do not differ by more than a factor of 2. If the earth resistances of single earth electrodes differ by more than a factor of 2, $k_c = 1$ is to be assumed.	

- H.6.7** Further information on partitioning of the lightning current amongst down-conductors is given in IS/IEC 62305-3 Annex C. For detailed evaluation of separation distance refer clause 6.3.3 of IS/IEC 62305-3

FIG. H-4

Directions for calculations of the separation distances, for a worst case Lightning interception point at a distance,  $l$ , from the reference point according



**Key**

- 1 metallic radiator/heater
- 2 wall of brickwork or wood
- 3 heater
- 4 equipotential bonding bar
- 5 earth-termination system
- 6 connection to the earth-termination system or to the down-conductor
- 7 worst case
- d actual distance
- l length for evaluation of separation distance,  $s$

**NOTE** The structure consists of insulating bricks.

## **H.7 Internal Lightning Protection and Protection of Electrical / Electronic Equipment from Surges**

The internal LPS shall avoid the occurrence of dangerous sparking within the structure to be protected due to lightning current flowing in the external LPS or in other conductive parts of the structure. Dangerous sparking between different parts can be avoided by means of equipotential bonding or electrical insulation between the parts.

Permanent failure of electrical and electronic systems can be caused by the lightning electromagnetic impulse (LEMP) via:

- a. conducted and induced surges transmitted to equipment via connecting wiring;
- b. the effects of radiated electromagnetic fields directly into equipment itself.

Surges to the structure can originate from sources external to the structure or from within the structure itself

- surges which originate externally from the structure are created by lightning flashes striking incoming lines or the nearby ground, and are transmitted to electrical and electronic systems within the structure via these lines
- surges which originate internally within the structure are created by lightning flashes striking the structure itself or the nearby ground. Surges can also originate internally within the structure from switching effects (e.g. switching of inductive loads).

The coupling can arise from different mechanisms

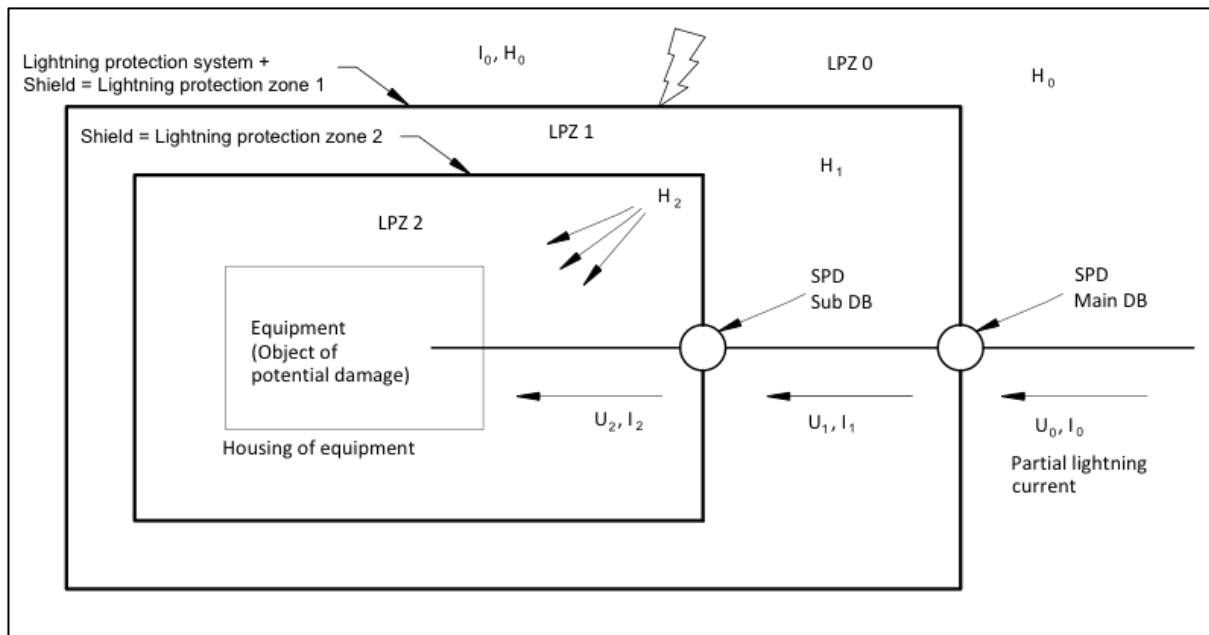
- resistive coupling (e.g. the earth impedance of the earth-termination system or the cable shield resistance);
- magnetic field coupling (e.g. caused by wiring loops in the electrical and electronic system or by inductance of bonding conductors)

In general electrical and electronic systems are subject to damage from a Lightning Electromagnetic impulse (LEMP). The wave shapes of lightning impulse and surges are given in IS/IEC 62305. Special Protection Measures (SPM) need to be provided to avoid failure of internal systems. The design of SPM should be carried out by experts in lightning and surge protection who possess a broad knowledge of EMC and civil/electrical installation practices.

### **H.7.1 Lightning Protection Zone Concept**

Protection against LEMP is based on the Lightning Protection Zone (LPZ) concept. The zone containing systems to be protected shall be divided into LPZs. These zones are theoretically assigned part of space (or of an internal system) where the LEMP severity is compatible with the withstand level of the internal system. Successive zones are characterized by significant changes in the LEMP severity. The boundary of an LPZ is defined by the protection measures employed.

**FIG. H-5**  
**SPM WITH SPATIAL SHIELDS AND A COORDINATED SPD SYSTEM**



Key

LPZ – Lightning Protection Zone

U – Conducted Surge Voltage,

I – Conducted Surge Current,

H – Radiated Magnetic field

$$(U_2 \ll U_1 \ll U_0)$$

$$(I_2 \ll I_1 \ll I_0)$$

$$(H_2 \ll H_1 \ll H_0)$$

### H.7.2 Equipment Protection Principles

**H.7.2.1** For protection against the effects of radiated electromagnetic fields impinging directly onto the equipment, SPM consisting of spatial shields and/or shielded lines, combined with shielded equipment enclosures should be used.

**H.7.2.2** For protection against the effects of conducted and induced surges being transmitted to the Equipment via connection wiring, SPM consisting of a coordinated SPD system should be used. SPD to be used according to their installation position are as follows

- a) At the line entrance into the structure (at the boundary of LPZ 1, for example at the Main Distribution Panel):
  - SPD tested with  $I_{imp}$  (typical waveform 10/350, for example, Type 1 SPD)
  - SPD tested with  $I_n$  (typical waveform 8/20, for example, Type 2 SPD)
- b) Close to the apparatus to be protected [at the boundary of LPZ 2 and higher, for example, at Secondary Distribution Board (SB), or at a socket outlet (SA)]:
  - SPD tested with  $I_n$  (typical waveform 8/20 for example, Type 2 SPD)
  - SPD tested with a combination wave (typical waveform 8/20 for example, Type 3 SPD)

**H.7.2.3** Failures due to electromagnetic fields impinging directly onto the equipment can be considered negligible provided the equipment complies with the relevant radio frequency emission and immunity EMC product standards.

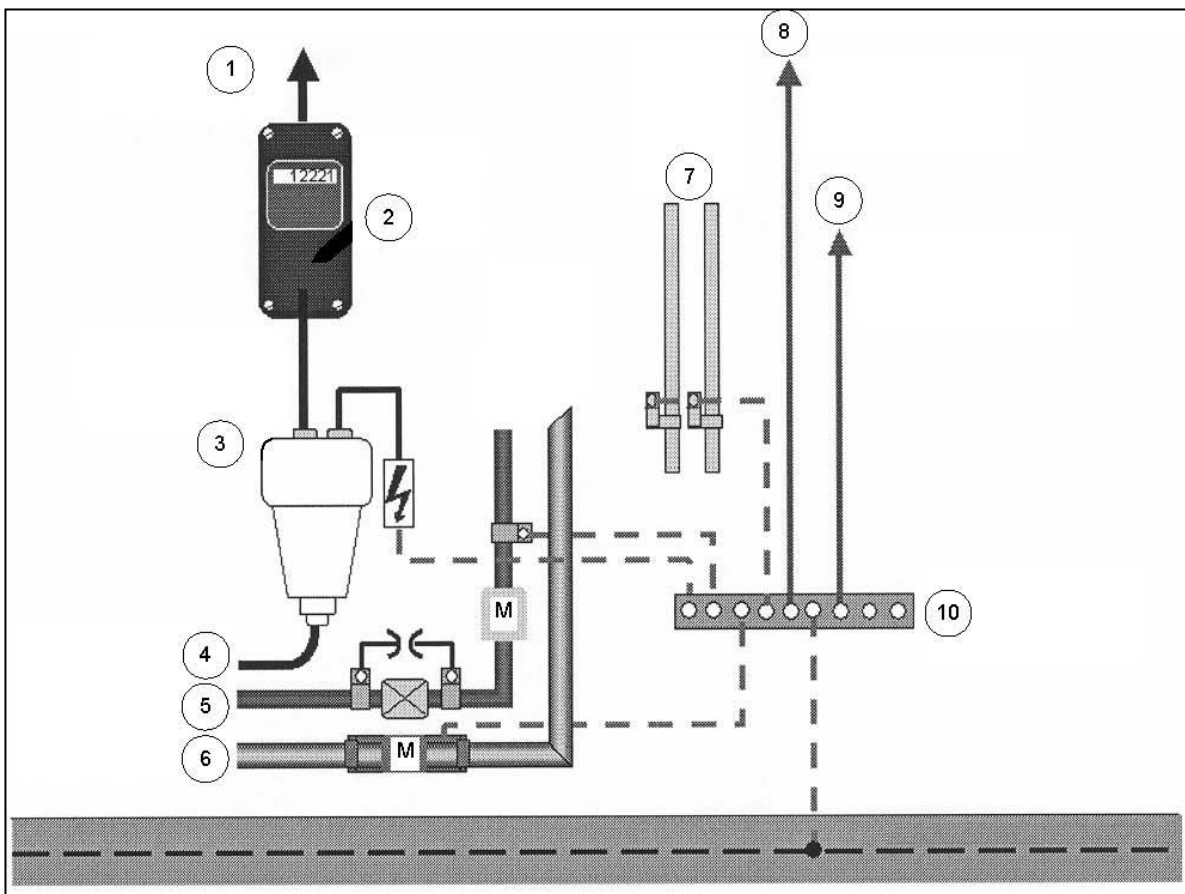
**H.7.2.4** In general, equipment is required to comply with the relevant EMC product standards therefore SPM consisting of a coordinated SPD system is usually considered sufficient to protect such equipment against the effects of LEMP.

**H.7.2.5** For equipment not complying with relevant EMC product standards, SPM consisting of a coordinated SPD system as well as additional magnetic shielding measures. Coordinates SPD protection should ensure the voltage impulses due to conducted surges are less than the voltage impulse withstanding capacity of the equipment. Shielding measures should ensure the radiated surges are within the withstanding capacity of the equipment.

**H.7.3 Equipotential Bonding of Incoming Metallic Services to LPS**

Equipotential Bonding is achieved by interconnecting the LPS with structural metal parts, metal installations, internal systems, external conductive parts and lines connected to the structure.

**FIG. H-6  
EXAMPLE OF AN EQUIPOTENTIAL BONDING ARRANGEMENT**



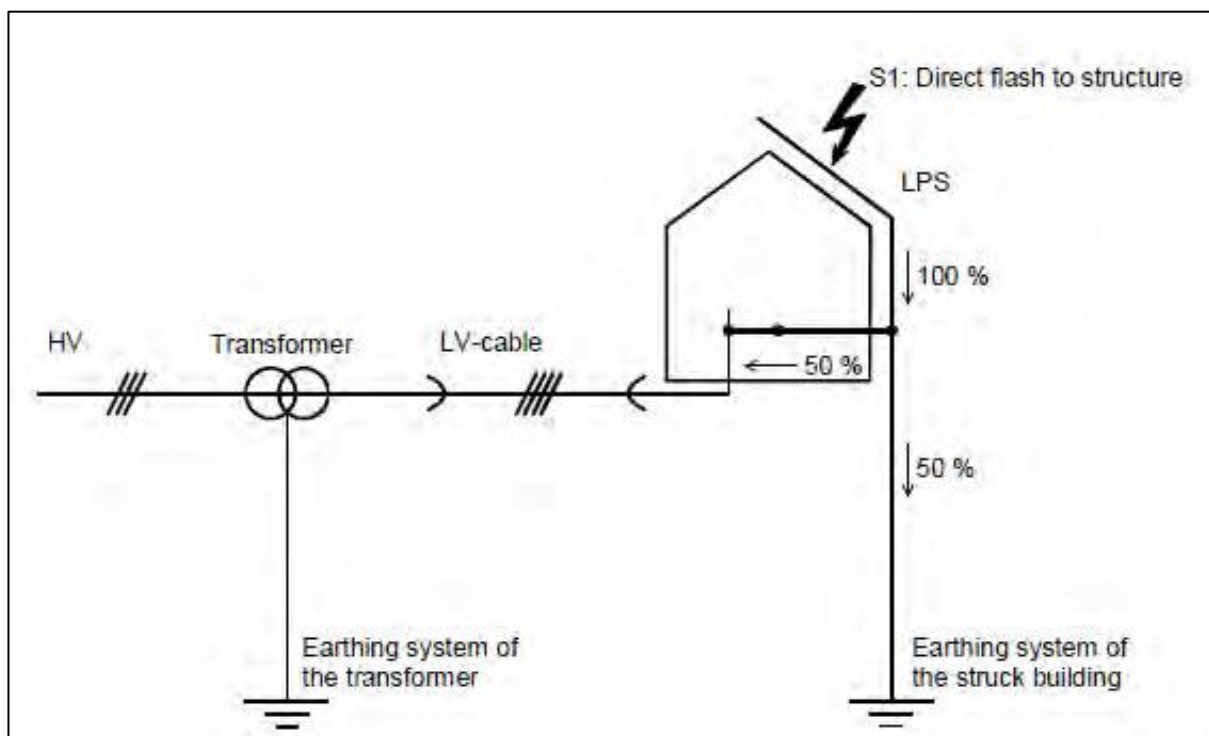
**Key**

- |                            |                |                                |                          |
|----------------------------|----------------|--------------------------------|--------------------------|
| 1. Power to user           | 2. Power meter | 3. House connection box        | 4. Power from utility    |
| 5. Gas                     | 6. Water       | 7. Central heating system      | 8. Electronic appliances |
| 9. Screen of antenna cable |                | 10. Equipotential bonding bar. |                          |
| S. Surge Protection Device | M. Meter       |                                |                          |

Interconnecting can be done with bonding conductors, where the electrical continuity is not provided by natural bonding or using surge protective devices (SPD's), where direct connections with bonding conductors is not feasible (eg installation of SPD's for Power, Data, Telecom lines

etc). SPD's shall be installed in such a way that they can be inspected. SPD is a device intended to limit transient over voltages and divert surge currents. It contains at least one non-linear component. All SPD's at the service entrance to an installation should be tested for 10/350  $\mu$ S Impulse current depending upon selected level of protection. A three phase four wire system should be designed for 50 percent of the total expected lightning current  $I_{imp}$  of selected LPL (ref LPL 1 to 4) and single phase two wire system should be designed for 25 percent of the total expected lightning current  $I_{imp}$  of selected LPL (ref LPL 1 to 4). For fire safety reason spark gap devices should not be used due to its follow current behaviour. The lightning current distribution for three phase four wire system is given in Fig. 9.7. Ref IS732 clause 5.3.5 for more information on selection and erection of SPD's.

**FIG. H-7**  
**BASIC EXAMPLE OF BALANCE CURRENT DISTRIBUTION (50 % of total lightning current is diverted to earth termination system and balance 50 % is diverted to the connected LV supply)**



#### H.7.4 Protection Measures with Surge Protection devices (SPD's)

**H.7.4.1** Lightning surges frequently cause failure of electrical and electronic systems due to insulation breakdown or when over voltages exceed the equipment's common mode insulation level. Equipment is protected if its rated impulse withstand voltage  $UW$  at its terminals is greater than the surge overvoltage between the live conductors and earth. If not, an SPD must be installed.

**H.7.4.2** Implementing coordinated SPD's will provide protection against radiated surges for equipment. Shielding and Routing of power and data lines, Bonding of Services and various Lightning Protection Zones (LPZ) (ref IS/IEC 62305-4), Earthing also plays major role in protecting electrical and electronic equipment.

**H.7.4.3 Failure of SPD's** - Possibility of failure of any line to neutral or neutral to earth connected SPDs should not be ruled out, hence measures should be taken within the SPD for safe failure or withstand in worst Temporary Over voltage conditions. SPD can fail in open or short modes. SPD should not create a fire hazard during failure. Type 1 and Type 2 SPD's with integrated back up protection (internal FUSE), pluggable and modular for each module shall be preferred.

**H.7.4.4 Status Indicators** - Each SPD should have inbuilt health indicator so as to show if protection is available. SPD should be installed in a way that visual inspection is easily possible. Failed SPD shall be replaced.

**H.7.4.5** SPD's for power line need to be installed according to the type of service such as TN, TT, IT, etc. In general the SPDs connected as per connection diagram given below is suitable for TN and TT connections.

**H.7.4.6** For Industrial and commercial buildings, critical and sensitive loads such as Drives, PLC's, automation panels etc require protection with SPD in addition to incoming power panels and sub distribution boards. For example, zones and hazardous area the SPDs shall be selected accordingly meeting the requirement of these zones.

**H.7.4.7** Lifts and escalators shall be protected with SPD in control panels

**H.7.4.8** All electrical and control panels related to safety and security of building shall be protected with appropriate SPDs.

**H.7.4.9** SPDs should be installed for outdoor equipment such as CCTV cameras, LED street lights, Weighbridges, Roof top SOLAR PV. This will ensure protection of people and equipment inside the building.

**H.7.4.10** Failure of equipment and chance of fire in electrical installations are more for buildings near tall structures (eg Telecom tower). These buildings should be protected with SPD at power incoming and Ring Earthing to avoid fire and equipment failure

**H.7.4.11** All SPDs should have status indication to show their healthy state for discharging the lightning current. The possibility of failure of L-N as well as N-PE connected SPD cannot be ignored.

**H.7.4.12** SPDs for data/telecommunication line shall be selected considering following parameters

- a) Place of installation (lightning protection zone concept),
- b) Immunity of terminal equipment,
- c) Earthing of the system to be protected (balanced/unbalanced),
- d) Requirement on interface (transmission parameters: Voltage, Freq, Current)
- e) Mounting interface.

## **H.8 Use of Natural Components As part of Lightning Protection System in new Buildings**

Natural components are conductive component installed in a building not specifically for lightning protection which can be used to provide the function of one or more parts of the LPS

Natural components made of conductive materials, which will always remain in/on the structure (e.g. interconnected steel-reinforcement, metal framework of the structure, steel

roof, metal façade, hand rails etc.) should be used as parts of an LPS such as air termination, down conductor and earthing if it satisfies the requirement according to table H-9 to H-11. Bonding of different metallic installations in the building should be done to avoid dangerous potential differences which results in flashover. This integrated method is not only economical but does not influence or spoil the aesthetics of the building. It also reduces the failure of electronic equipment inside the building from radiated lightning effects.

In case of natural down-conductors combined with foundation earth electrodes, test joints are not required and earth resistance measurements are not necessary.

### **H.8.1 Continuity of steelwork in reinforced concrete structures**

Steelwork within reinforced concrete structures is considered to be electrically continuous provided that the major part of interconnections of vertical and horizontal bars are welded or otherwise securely connected. Connections of vertical bars shall be welded, clamped or overlapped a minimum of 20 times their diameters and bound or otherwise securely connected.

For structures utilizing steel reinforced concrete (including pre-cast, pre-stressed reinforced units), the electrical continuity of the reinforcing bars shall be determined by electrical testing between the uppermost part and ground level. The overall electrical resistance should not be greater than  $0,2 \Omega$ , measured using test equipment suitable for this purpose. If this value is not achieved, or it is not practical to conduct such testing, the reinforcing steel shall not be used as a natural down-conductor. In this case it is recommended that an external down-conductor be installed: In the case of structures of pre-cast reinforced concrete, the electrical continuity of the reinforcing steel shall be established between individual adjacent pre-cast concrete units

### **H.8.2 Bonding Network**

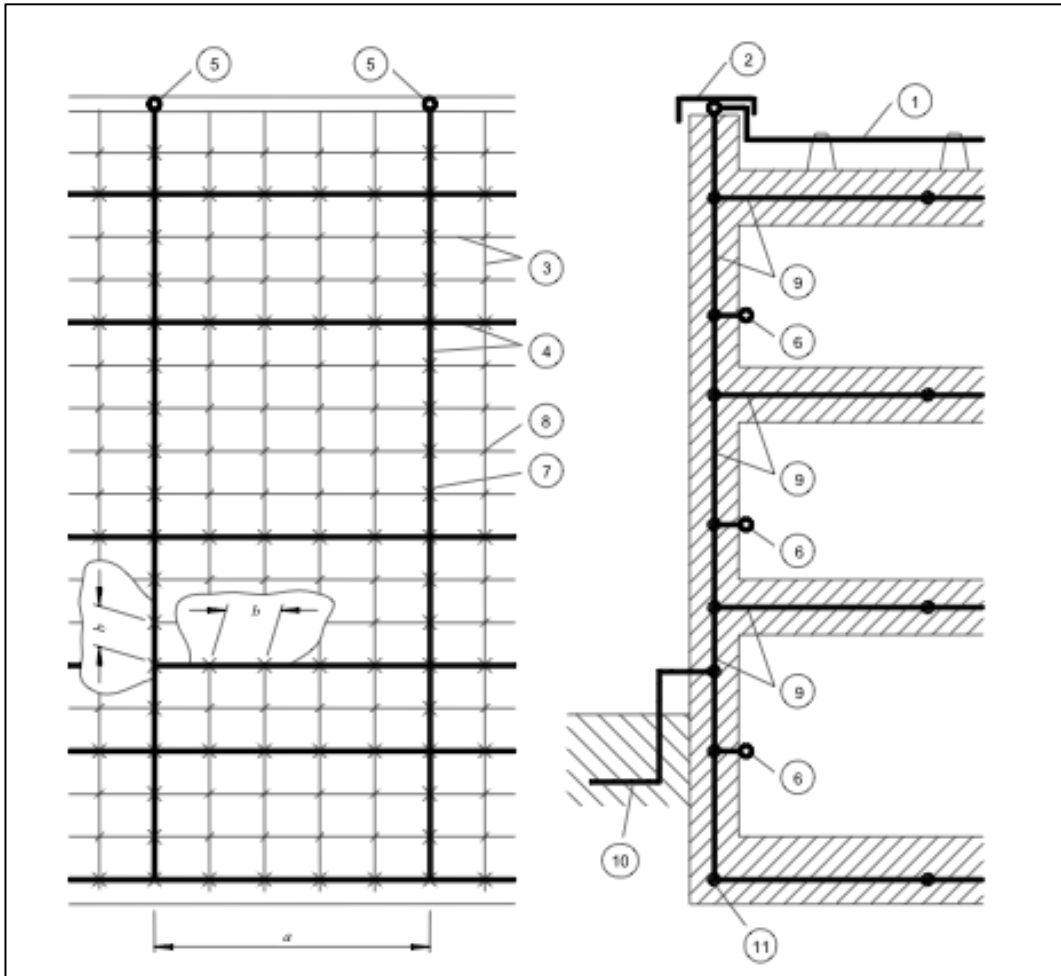
A low impedance bonding network is needed to avoid dangerous potential differences between all equipment inside the building. Moreover, such a bonding network also reduces the magnetic field, thereby reduces the radiated surges inside the building and provides more protection for electronic equipment (see IS/IEC 62305-4 Annex A).

This can be realised by a meshed bonding network integrating conductive parts of the structure, or parts of the internal systems, and by bonding metal parts or conductive services at the boundary of each LPZ directly or by using suitable SPDs.

The bonding network can be arranged as a three-dimensional meshed structure with a typical mesh width of 5 m. This requires multiple interconnections of metal components in and on the structure (such as concrete reinforcement, elevator rails, cranes, metal roofs, metal facades, metal frames of windows and doors, metal floor frames, service pipes and cable trays). Bonding bars (e.g. ring bonding bars, several bonding bars at different levels of the structure) and magnetic shields of the LPZ shall be integrated in the same way.

Conductive parts (e.g. cabinets, enclosures, racks) and the protective earth conductor (PE) of the internal systems shall be connected to the bonding network.

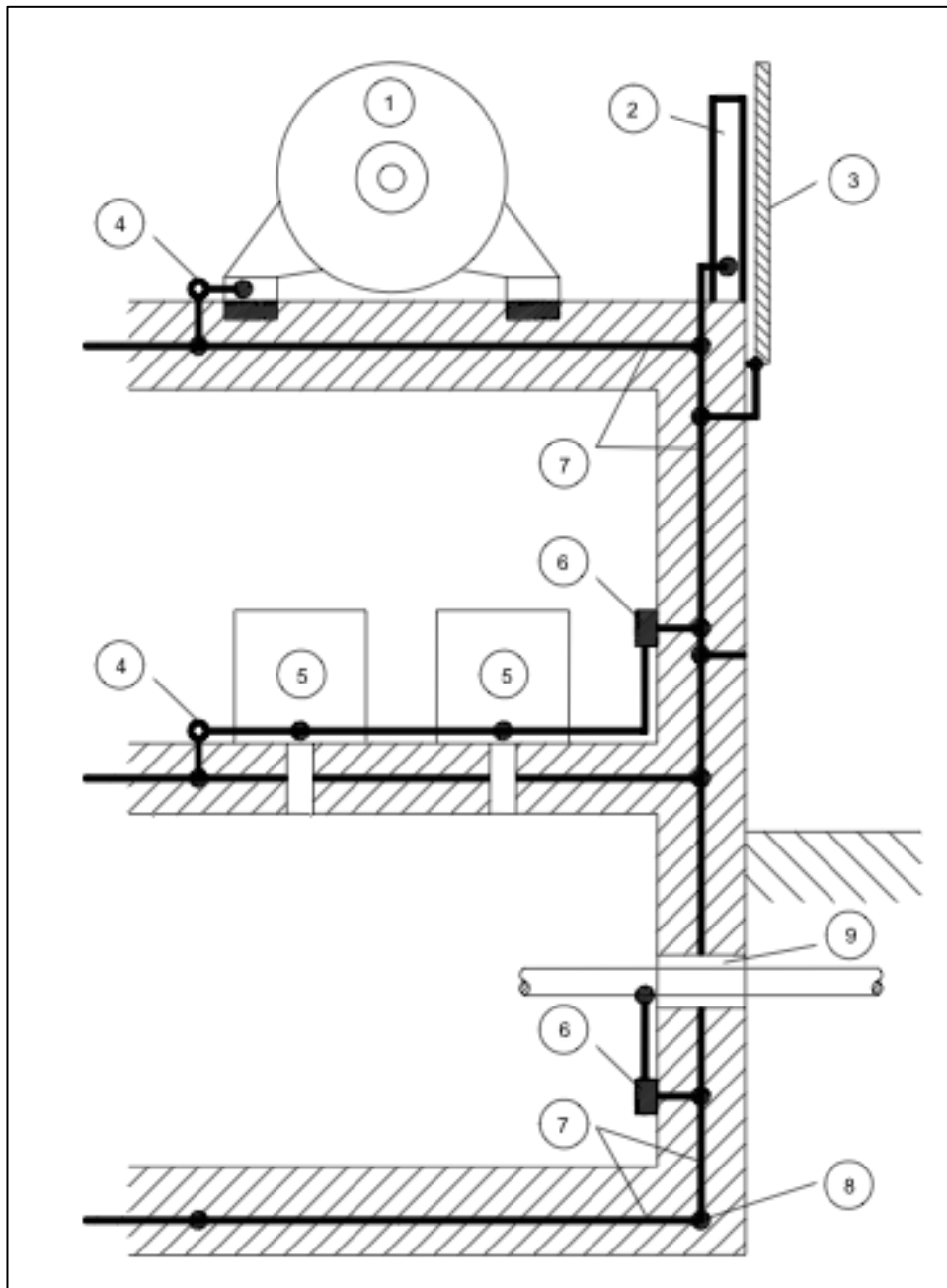
**FIG. H-8**  
**UTILISATION OF REINFORCING RODS OF A STRUCTURE FOR**  
**EQUIPOTENT BONDING**



**Key**

- |    |   |   |   |
|----|---|---|---|
| 1  | air-termination conductor   | 7 | Connection made by welding or clamping                              |
| 2  | metal covering of the roof parapet(or handrail)                     | 8 | Arbitrary connection  |
| 3  | Steel reinforcing rods  | 9 | Steel reinforcement in concrete (with super imposed mesh conductor) |
| 4  | Mesh conductors superimposed on the reinforcement                   | 1 | Ring earthing electrode (if any)                                    |
| 5  | Joint of the mesh conductor   | 0 |   |
|    |   | 1 | Foundation earthing electrode                                       |
| 6  | Joint of the internal bonding bar                                   | 1 |   |
| a. | typical distance of 5 m for superimposed mesh conductor             |   |   |
| b. | typical distance of 1 m for connecting this mesh with reinforcement |   |   |

**FIG. H-9  
EQUIPOTENTIAL BONDING IN A STRUCTURE WITH STEEL REINFORCEMENT**



- |                                      |   |
|--------------------------------------|---|
| 1 Electrical power equipment         | 6 Bonding bar   |
| 2 Steel girder                       | 7 Steel reinforcement in concrete (with superimposed mesh conductors) |
| 3 Metal covering of the façade       | 8 Foundation earth electrode  |
| 4 Bonding joint                      | 9 Common entry point for different services                           |
| 5 Electrical or electronic equipment |   |

### H.9 Materials and Dimensions:

Copper and aluminium are recommended for exposed areas on installations required to have a long life. Galvanized steel may be preferred for temporary installations such as exhibition centres. Although it is a common practice to use material in the form of strip for horizontal air terminations, down conductors and bonds, it is more convenient to use round material, particularly as it facilitates the making of bends in any plane. If different materials are used in an installation, care should be taken to avoid galvanic corrosion by the use of Bi metallic connectors. See Tables H-9 to H-11 for details.

**Table H-9: LPS materials and conditions of use**  
(Clause H.9, 9.4.1)

Material	Use			Corrosion		
	In open air	In earth	In concrete	Resistance	Increased by	May be destroyed by galvanic coupling with
Copper	Solid Stranded	Solid Stranded As coating	Solid Stranded As coating	Good in many environments	Sulphur compounds Organic materials	–
Hot galvanized steel <sup>c. d. e.</sup>	Solid Stranded	Solid	Solid Stranded	Acceptable in air, in concrete and in benign soil	High chlorides content	Copper
Steel with electro deposited copper	Solid	Solid	Solid	Good in many environments	Sulphur compounds	
Stainless steel	Solid Stranded	Solid Stranded	Solid Stranded	Good in many environments	High chlorides content	–
Aluminium	Solid Stranded	Unsuitable	Unsuitable	Good in atmospheres containing low concentrations of sulphur and chloride	Alkaline solutions	Copper
<p>a. This table gives general guidance only. In special circumstances more careful corrosion immunity considerations are required</p> <p>b. Stranded conductors are more vulnerable to corrosion than solid conductors. Stranded conductors are also vulnerable where they enter or exit earth/concrete positions. This is the reason why stranded galvanized steel is not recommended in earth.</p> <p>c. Galvanized steel may be corroded in clay soil or moist soil.</p> <p>d. Galvanized steel in concrete should not extend into the soil due to possible corrosion of the steel just outside the concrete.</p> <p>e. Galvanized steel in contact with reinforcement steel in concrete may, under certain circumstances, cause damage to the concrete.</p> <p>Note: Lead specified in [8-2(27)] is removed due to environmental concerns</p>						

**Table H-10**

**Material, Configuration and Minimum Cross-sectional area of air-termination conductors and rods, earth lead-in rods and down conductors <sup>a</sup>**

(Clause H.9, 9.4.1)

<b>Material</b>	<b>Configuration</b>	<b>Minimum cross-sectional area mm<sup>2</sup></b>
Copper Tin plated Copper	Solid tape	50
	Solid round <sup>b</sup>	50
	Stranded <sup>b</sup>	50
	Solid round <sup>c</sup>	176
Aluminium	Solid tape	70
	Solid round	50
	Stranded	50
Aluminium Alloy	Solid tape	50
	Solid round	50
	Stranded	50
	Solid round <sup>c</sup>	176
Copper coated aluminium alloy	Solid round	50
Hot dipped galvanised steel	Solid tape	50
	Solid round	50
	Stranded	50
	Solid round <sup>c</sup>	176
Copper coated steel	Solid round	50
	Solid tape	50
Stainless steel	Solid tape <sup>d</sup>	50
	Solid round <sup>d</sup>	50
	Stranded	50
	Solid round <sup>c</sup>	176

- a. Mechanical and electrical characteristics as well as corrosion resistance properties shall meet the requirements of IS IEC 62561 series
- b. 50 mm<sup>2</sup> (8 mm diameter) may be reduced to 25 mm<sup>2</sup> in certain application where mechanical strength is not an essential requirement. Consideration should in this case, given to reducing the space between fastners
- c. Applicable for air-termination rods and earth lead-in rods. For air-termination rods where mechanical stress such as windloading is not critical, a 9.5 mm diameter, 1 meter long rod may be used.
- d. If the thermal and mechanical considerations are important, then these values should be increased to 75 mm<sup>2</sup>

**Table H-11**  
**Material Configuration and Minimum Dimensions of Earth Electrodes**  
*(Clause H.9, 9.4.1)*

Material	Configuration	Minimum dimensions		
		Earth rod diameter mm	Earth conductor mm <sup>2</sup>	Earth plate mm
Copper Tin plated Copper	Stranded		50	
	Solid round	15	50	
	Solid Tape		50	
	Pipe	20		
	Solid plate			500 x 500
	Lattice plate <sup>c</sup>			600 x 600
Hot dipped galvanised steel	Solid round	14	78	
	Pipe	25		
	Solid tape		90	
	Solid plate			500 x 500
	Lattice plate			600 x 600
	Profile	d		
Bare steel <sup>b</sup>	Stranded		70	
	Sold round		78	
	Solid tape		75	
Copper Coated Steel	Sold round	14 <sup>f</sup>	50	
	Solid tape		90	
Stainless steel <sup>g</sup>	Solid round	15	78	
	Solid tape		100	

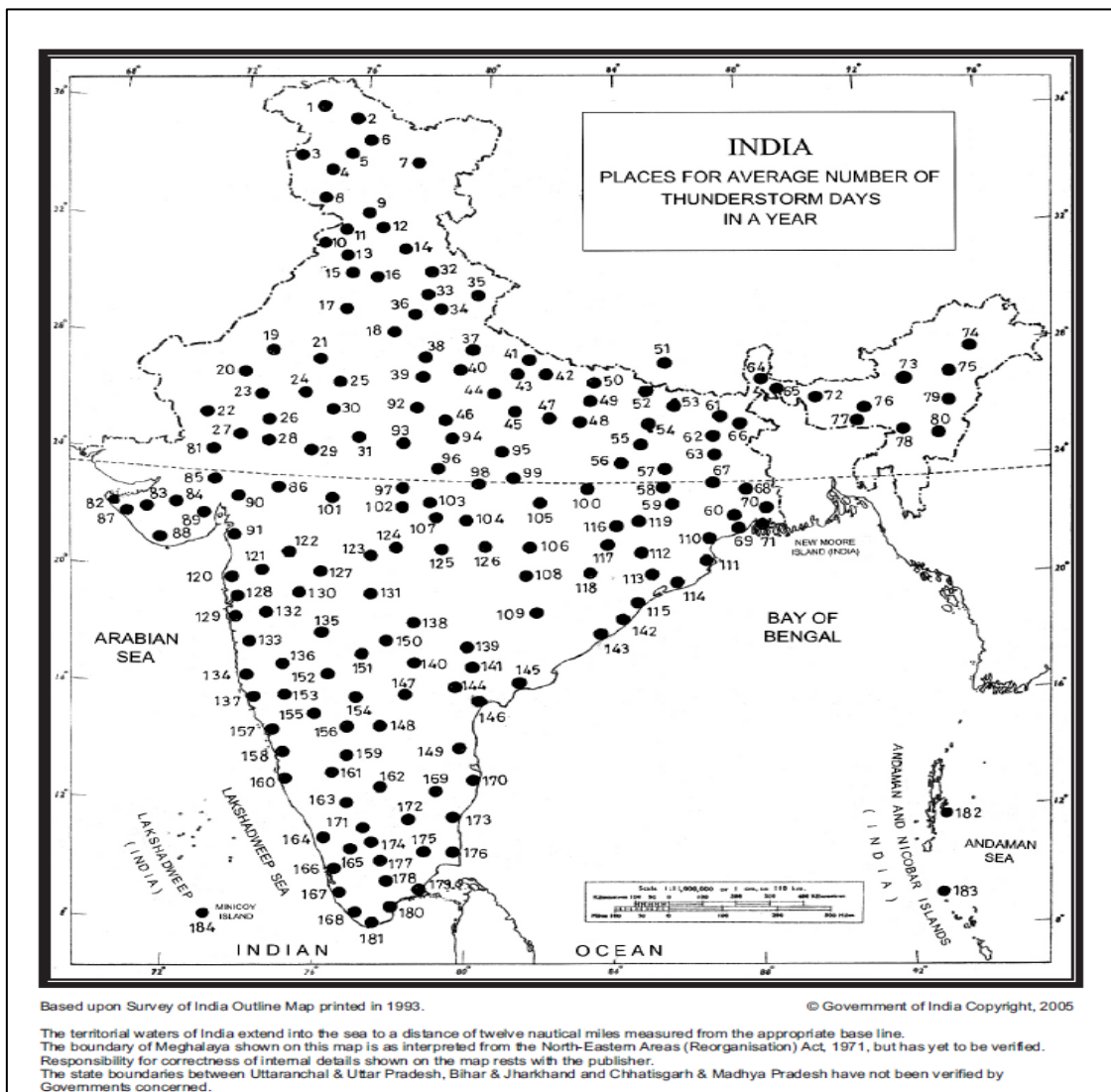
- a. Mechanical and electrical characteristics as well as corrosion resistance properties shall meet the requirements of IS IEC 62561 series
- b. Shall be embedded in concrete for a minimum depth of 50 mm
- c. Lattice plate constructed with a minimum total length of conductor of 4.8 meter
- d. Different profiles are permitted with a cross-section of 290 mm<sup>2</sup> and a minimum thickness of 3 mm. e.g. cross profile
- e. Incase of a type B arrangement foundation earthing system, the earth electrode shall be correctly connected at least every 5 meters with the reinforcement steel.
- f. 250µm minimum radial copper coating, with 99,9 % copper content
- g. Chromium □□16 %, nickel □□5 %, molybdenum □□2 %, carbon □□0,08 %.

**Table H-12**  
**Information: Annual Thunderstorm Days**  
**For the purpose of risk assessment, annual thunderstorm days in various places**  
**are provided in the below table. H-12**

Name of place with number of thunderstorm days								
Sl. No.	Name of Place	Annual Thunder storm Days	Sl. No.	Name of Place	Annual Thunder storm Days	Sl. No.	Name of Place	Annual Thunder storm Days
1	Gilgit	7	62	Sabour	76	123	Akola	20
2	Skardu	5	63	Dumka	63	124	Amraoti	32
3	Gulmarg	53	64	Darjeeling	28	125	Nagpur	45
4	Srinagar	54	65	Jalpaiguri	68	126	Gondia	10
5	Dras	3	66	Malda	59	127	Aurangabad	34
6	Kargil	2	67	Asansol	71	128	Bombay	16
7	Leh	3	68	Burdwan	39	129	Alibag	12
8	Jammu	26	69	Kharagpur	76	130	Ahmadnagar	10
9	Dharmasala	13	70	Calcutta	70	131	Parbhani	32
10	Amritsar	49	71	Sagar Island	41	132	Pune	22
11	Pathankot	4	72	Dhubri	8	133	Mahabaleshwar	14
12	Mandi	46	73	Tezpur	27	134	Ratnagiri	6
13	Ludhiana	12	74	Dibrugarh	98	135	Sholapur	23
14	Simla	40	75	Sibsagar	103	136	Miraj	25
15	Patiala	26	76	Shillong	75	137	Vengurla	39
16	Ambala	9	77	Cherrapunji	49	138	Nizambad	36
17	Hissar	27	78	Silchar	33	139	Hnamkonda	43
18	Delhi	30	79	Kohima	34	140	Hyderabad	28
19	Bikaner	10	80	Imphal	49	141	Khammam	26
20	Phalodi	14	81	Deesa	7	142	Kalingapatam	20
21	Sikar	17	82	Dwarka	5	143	Vishakapatnam	46
22	Barmer	12	83	Jamnagar	8	144	Rentichintala	42
23	Jodhpur	23	84	Rajkot	12	145	Masulipatam	20
24	Ajmer	26	85	Ahmedabad	11	146	Ongole	25
25	Jaipur	39	86	Dohad	17	147	Kurnool	29
26	Kankroli	36	87	Porbandar	3	148	Anantpur	22
27	Mount Abu	5	88	Veraval	3	149	Nellore	18
28	Udaipur	38	89	Bhavnagar	11	150	Bidar	15
29	Neemuch	28	90	Baroda	8	151	Gulbarga	34
30	Kota	27	91	Surat	4	152	Bijapur	9
31	Jhalawar	40	92	Gwalior	53	153	Belgaum	31
32	Mussorie	61	93	Guna	33	154	Raichur	17
33	Roorkee	74	94	Nowgong	59	155	Gadag	21
34	Najibabad	36	95	Satna	41	156	Bellary	22
35	Mukteswar	53	96	Sagar	36	157	Karwar	27
36	Meerut	-	97	Bhopal	44	158	Honavar	5
37	Bareilly	34	98	Jabalpur	50	159	Chikalhana	24
38	Aligarh	30	99	Umaria	37	160	Mangalore	36
39	Agra	24	100	Ambikapur	29	161	Hassan	26
40	Mainpuri	23	101	Indore	34	162	Bangalore	46
41	Bahraich	31	102	Hoshangabad	37	163	Mysore	44
42	Gonda	22	103	Panchmarhi	30	164	Kozhikode	39
43	Lucknow	18	104	Seoni	51	165	Palghat	35

44	Kanpur	26	105	Pendadah	56	166	Cochin	69
45	Fatehpur	24	106	Raipur	34	167	Alleppey	51
46	Jhansi	20	107	Chhindwara	27	168	Trivandrum	68
47	Allahabad	51	108	Kanker	37	169	Vellore	25
48	Varanasi	51	109	Jagdapur	35	170	Madras	47
49	Azamgarh	1	110	Balasure	81	171	Ootacamund	24
50	Gorakhpur	11	111	Chandbali	75	172	Salem	69
51	Katmandu	74	112	Angul	81	173	Cuddalore	37
52	Motihari	38	113	Bhubaneswar	46	175	Trichchirapalli	41
53	Darbhangha	10	114	Puri	33	176	Nagappattinam	15
54	Patna	33	115	Gopalpur	34	177	Kodaikanal	82
55	Gaya	38	116	Jharsuguda	85	178	Madurai	39
56	Daltonganj	73	117	Sambalpur	67	179	Pamban	5
57	Hazaribagh	73	118	Titlagarh	24	180	Tuticorin	14
58	Ranchi	34	119	Rajgangpur	1	181	Cape Comorin	68
59	Chaibasa	70	120	Dahanu	1	182	Port Blair	62
60	Jamshedpur	66	121	Nasik	17	183	Car Nicobar 1	18
61	Purnea	52	122	Malegaon	13	184	Minicoy 1	20

**Fig H-10**  
**Map of India showing places for average number of thunderstorm days in an year**



## APPENDIX I

### Specification and Testing of power switchgear and control gear assemblies and Bus Bar/Rising Mains

**A) Table I-1: The specification/detail of power switchgear and control gear assemblies (PSC-ASSEMBLIES) (LT Panels) (up to 1 kV AC)**

S.No.	Characteristics	Reference clause or sub-clauses of IS/IEC 61439-2	Default arrangement	Options listed in standard in IS/IEC 61439-2	User requirement to be filled by NIT authority
<b>(1)</b>	<b>Electrical system</b>				
(a)	Earthing system	5.6, 8.4.3.1, 8.4.3.2.3, 8.6.2, 10.5, 11.4	Manufacturer's standard, selected to suit local requirements	TT/TN-C/TN-C-S/IT, TN-S	
(b)	Nominal voltage (V)	3.8.9.1, 5.2.1, 8.5.3	Local, according to installation conditions	max 1000 V a.c. or 1500 V d.c.	
(c)	Transient over voltages	5.2.4, 8.5.3, 9.1, Annex G	Determined by the electrical system	Overvoltage category I/II/III/IV	
(d)	Temporary over voltages	9.1	Nominal system voltage + 1 200 V	None	
(e)	Rated frequency fn (Hz)	3.8.12, 5.5, 8.5.3, 10.10.2.3, 10.11.5.4	According to local installation conditions	d.c./50 Hz/60 Hz	
(f)	Additional onsite testing requirements: wiring, operational performance and function	11.10	Manufacturer's standard, according to application	None	
<b>(2)</b>	<b>Short-circuit withstand capability</b>				
(a)	Prospective short-circuit current at supply terminals Icp (kA)	3.8.7	Determined by the electrical system	None	
(b)	Prospective short-circuit current in the neutral	10.11.5.3.5	Max. 60 % of phase values	None	
(c)	Prospective short-circuit current in the protective circuit	10.11.5.6	Max. 60 % of phase values	None	
(d)	SCPD in the incoming functional	9.3.2	According to local	Yes / No	

	unit requirement		installation conditions		
(e)	Co-ordination of short-circuit protective devices including external short-circuit protective device details	9.3.4	According to local installation conditions	None	
(f)	Data associated with loads likely to contribute to the short-circuit current	9.3.2	No loads likely to make a significant contribution allowed for	None	
<b>(3)</b>	<b>Protection of persons against electric shock in accordance with IEC 60364-4-41</b>				
(a)	Type of protection against electric shock– Basic protection (protection against direct contact)	8.4.2	Basic protection	According to local installation regulations	
(b)	Type of protection against electric shock–Fault protection (protection against indirect contact)	8.4.3	According to local installation conditions	Automatic disconnection of supply/Electrical separation/ Total insulation	
<b>(4)</b>	<b>Installation environment</b>				
(a)	Location type	3.5, 8.1.4, 8.2	Manufacturer's standard, according to application	Indoor/ outdoor	
(b)	Protection against ingress of solid foreign bodies and ingress of water	8.2.2, 8.2.3	Indoor (enclosed): IP 2X Outdoor (min.): IP 23	IP 2X, 3X, 4X, 5X, 6X	
(c)	Protection after removal of withdrawable part	8.2.101	Manufacturer's standard	As for connected position / Reduced protection to manufacturer's standard	
(d)	External mechanical	8.2.1,	None		

	impact (IK)	10.2.6			
(e)	Resistance to UV radiation (applies for outdoor assemblies only unless specified otherwise)	10.2.4	Indoor: Not applicable. Outdoor: Temperate climate	None	
(f)	Resistance to corrosion	10.2.2	Normal Indoor/Outdoor arrangements	None	
(g)	Ambient air temperature – Lower limit	7.1.1	Indoor: –5 °C Outdoor: –25 °C	None	
(h)	Ambient air temperature – Upper limit	7.1.1	40 °C	None	
(i)	Ambient air temperature – Daily average maximum	7.1.1, 9.2	35 °C	None	
(j)	Maximum relative humidity	7.1.2	Indoor: 50 % at 40 °C Outdoor: 100 % at 25 °C	None	
(k)	Pollution degree (of the installation environment)	7.1.3	Industrial: 3	1, 2, 3, 4	
(l)	Altitude	7.1.4	≤ 2 000 m	None	
(m)	EMC environment (A or B)	9.4, 10.12, Annex J	A/B	A/B	
(n)	Special service conditions (e.g. vibration, exceptional condensation, heavy pollution, corrosive environment, strong electric or magnetic fields, fungus, small creatures, explosion hazards, heavy vibration and shocks,	7.2, 8.5.4, 9.3.3 Table 7,	No special service conditions	None	
<b>(5)</b>	<b>earthquakes)</b>				
	<b>Installation method</b>				
(a)	Type	3.3, 5.6	Manufacturer's standard	Various e.g. floor standing / wall mounted	
(b)	Stationary/Movable	3.5	Stationary	Stationary / movable	
(c)	Maximum overall	5.6, 6.2.1	Manufacturer's	None	

	dimensions and weight		standard, according to application		
(d)	External conductor type(s)	8.8	Manufacturer's standard	Cable / Busbar Trunking System	
(e)	Direction(s) of external conductors	8.8	Manufacturer's standard	None	
(f)	External conductor material	8.8	Copper	Copper / aluminium	
(g)	External phase conductor, cross sections, and terminations	8.8	As defined within the standard	None	
(h)	External PE, N, PEN conductors cross sections, and terminations	8.8	As defined within the standard	None	
(i)	Special terminal identification requirements	8.8	Manufacturer's standard	None	
<b>(6)</b>	<b>Storage and handling</b>				
(a)	Maximum dimensions and weight of transport units	6.2.2, 10.2.5	Manufacturer's standard	None	
(b)	Methods of transport (e.g. forklift, crane)	6.2.2, 8.1.6	Manufacturer's standard	None	
(c)	Environmental conditions different from the service conditions	7.3	As service conditions	None	
(d)	Packing details	6.2.2	Manufacturer's standard	None	
<b>(7)</b>	<b>Operating arrangements</b>				
(a)	Access to manually operated devices	8.4		Authorized persons / Ordinary persons	
(b)	Location of manually operated devices	8.5.5	Easily accessible	None	
(c)	Isolation of load installation equipment items	8.4.2, 8.4.3.3, 8.4.6.2	Manufacturer's standard	Individual / groups / all	
<b>(8)</b>	<b>Maintenance and upgrade capabilities</b>				
(a)	Requirements related to accessibility for inspection and similar operations	8.4.6.2.2	No requirements for accessibility	None	
(b)	Requirements related	8.4.6.2.3	No	None	

	to accessibility for maintenance in service by authorized persons		requirements for accessibility		
(c)	Requirements related to accessibility for extension in service by authorized persons	8.4.6.2.4	No requirements for accessibility	None	
(d)	Method of functional units connection	8.5.1, 8.5.2	Manufacturer's standard	None	
(e)	Protection against direct contact with hazardous live internal parts during maintenance or upgrade (e.g. functional units, main busbars, distribution busbars)	8.4	No requirements for protection during	None	
(f)	Gangways	8.4.6.2.101		None	
(g)	Method of functional unit's connection NOTE This refers to the capability of removal and re-insertion of functional units.	8.5.101		F fixed connections D disconnectable connections W withdrawable connections	
(h)	Form of separation	8.101		From 1,2,3,4	
(i)	Capability to test individual operation of the auxiliary circuits relating to specified circuits while the functional unit is isolated	3.1.102, 3.2.102 3.2.103, 8.5.101, Table 103		None	
<b>(9)</b>	<b>Current carrying capability</b>				
(a)	Rated current of the ASSEMBLY In A(amps)	3.8.9.1,5.3, 8.4.3.2.3,8.5.3, 8.8,10.10.2, 10.10.3, 10.11.5, Annex E	Manufacturer's standard, according to application	None	
(b)	Rated current of circuits 'nc (amps)	5.3.2	Manufacturer's standard, according to application	None	
(c)	Rated diversity factor	5.4,10.10.2.3, Annex E	As defined within the standard	RDF for groups of circuits / RDF for whole	

				ASSEMBLY	
(d)	Ratio of cross section of the neutral conductor to phase conductors: phase conductors up to and including 16 mm <sup>2</sup>	8.6.1	100%	None	
(e)	Ratio of cross section of the neutral conductor to phase conductors: phase conductors above 16 mm <sup>2</sup>	8.6.1	50% (min. 16mm <sup>2</sup> )	None	
(a) For exceptionally onerous applications, the user may need to specify more stringent requirements to those in the standard.					
(b) In some cases information declared by the ASSEMBLY manufacturer may take the place of an agreement.					

### Design verification

**Table I-2 List of parameters for design verifications to be performed for Power switchgear and control gear assemblies (PSC-ASSEMBLIES) ( LT Panels)**

S.No.	Characteristic to be verified	Clauses or Sub clauses of IEC 61439-2	Verification options available		
			Verification by testing	Verification by calculation	Verification by design rules
1	Strength of material and parts:	10.2	YES	NO	NO
	Resistance to corrosion	10.2.2			
	Properties of insulating materials:	10.2.3			
	Thermal stability	10.2.3.1	YES	NO	NO
	Resistance of insulating materials to normal heat	10.2.3.2	YES	NO	NO
	Resistance to abnormal heat and fire due to internal electric effects	10.2.3.3	YES	NO	NO
	Resistance to ultra-violet (UV) radiation	10.2.4	YES	NO	NO
	Lifting	10.2.5	YES	NO	NO
Mechanical impact	10.2.6	YES	NO	NO	
Marking	10.2.7	YES	NO	NO	
2	Degree of protection of enclosures	10.3	YES	NO	YES
3	Clearances and Creepage distances	10.4	YES	YES	YES
4	Protection against electric shock and integrity of protective circuits:	10.5			
	Effective continuity	10.5.2	YES	NO	NO

	between the exposed conductive parts of the Assembly and the protective circuit				
	Effectiveness of the assembly for external faults	10.5.3	YES	YES	YES
5	Incorporation of switching devices and components	10.6	NO	NO	YES
6	Internal electrical circuits and connections	10.7	NO	NO	YES
7	Terminals for external conductors	10.8	No	NO	YES
8	Dielectric properties:	10.9			
	Power-frequency withstand voltage	10.9.2	YES	NO	NO
	Impulse withstand voltage	10.9.3	YES	NO	YES
9	Temperature-rise limits	10.10	YES	YES	YES
10	Short-circuit withstand strength	10.11	YES	YES	YES
11	Electromagnetic compatibility (EMC)	10.12	YES	NO	YES
12	Mechanical operation	10.13	YES	NO	NO

**Note:** Verification by tested shall precede the verification by other two methods.

### Specification schedule

**Table I.3-User specification schedule of Bus Trunking, Rising Mains**

Characteristics	Reference sub-clause IEC 61439-6	Default arrangement	Options	Req.
<b>Electrical system</b>				
Earthing system	5.6, 8.4.3.1, 8.4.3.2.3, 8.6.2, 10.5.11.4	Manufacturer's standard. selected to suit local requirements	TT/TN-C/ TN-C-S/IT/TN-S	
Nominal voltage $U_n$ (V)	3.8.9.1, 5.2.1., 8.5.3	Local, according to installation conditions	<1,000 V a.c. or 1 500 V d.c	
Transient overvoltages	5.2.4, 8.5.3.9.1, Annex G	Determined by the electrical system	Overvoltage category III/IV	
Temporary overvoltages	9.1	Nominal system voltage + 1200 V	None	
Rated frequency $f_n$ (Hz)	3.8.12, 5.5, 8.5.3, 10.10.2.3.	According to local installation conditions	d.c./ 50 Hz/60 Hz	

	10.11.5.4			
Additional onsite testing requirements: wiring, and electrical working	11.10	Manufacturer's standard, according to application	None	
<b>Short circuit withstand capability</b>				
Prospective short-circuit current at supply terminals $I_{cp}$ (kA)	3.8.7	Determined by the electrical system	None	
Prospective short-circuit current in the neutral	10.11.5.3.5	Max. 60% of phase values	None	
Prospective short-circuit current In the protective circuit	10.11.5.6	Max. 60% of phase values	None	
SCPD in the incoming functional unit	9.3.2	According to local installation conditions	Yes/No	
Co-ordination of short-circuit protective devices including external short-circuit protective device details	9.3.4	According to local installation conditions	None	
Data associated with loads likely to contribute to the short-circuit current	9.3.2	No loads likely to make a significant contribution	None	
Fault loop characteristics	5.101, Annex CC, Annex DD	Manufacturer's standard	None	
<b>Protection of persons against electric shock In accordance with IEC 60364-4-41</b>				
Type of protection against electric shock- Basic protection (protection against direct contact)	8.4.2	Basic protection	According to local installation regulations	
Type of protection against electric shock- Fault protection (protection against indirect contact)	8.4.3	According to local installation conditions	Automatic disconnection of supply/ Elec. separation/ Total insulation	
<b>Installation environment</b>				
Location type	3.5, 8.1.4, 8.2	Manufacturer's	Indoor/outdoor	

		standard. according to application		
Protection against ingress of solid foreign bodies and ingress of water	8.2.2, 8.2.3	Indoor (enclosed) IP 2X Outdoor: IP 23	After removal of tap-off units: as for connected position/reduced protection	
External mechanical impact (IK)	8.2.1, 10.2.6	None	None	
Mechanical loads	5.6, 8.1.101. 10.2.101	Normal	Normal/heavy	
Resistance to UV radiation (applies for outdoor BTS only unless otherwise specified)	10.2.4	Indoor/outdoor	Indoor/outdoor	
Resistance to corrosion	10.2.2	Indoor/outdoor	Indoor/outdoor	
Ambient air temperature-Lower limit	7.1.1	Indoor: -5 °C Outdoor-25°C	None	
Ambient air temperature-Upper limit	7.1.1	40 °C	None	
Ambient air temperature-Daily average maximum	7.1.1, 9.2	35 °C	None	
Maximum relative humidity	7.1.2	Indoor 50% at 40 °C Outdoor 100% at 25 °C	None	
Pollution degree (of the installation environment)	7.1.3	Industrial: 3	1,2,3,4	
Altitude	7.1.4	<2 000 m	None	
EMC environment	9.4, 10.12, Annex J	A/B	A/B	
Electromagnetic field	5.102	Manufacturer's standard	None	
Resistance to flame propagation	5.6, 9.101, 10.101	No	Yes/No	
Fire resistance in building penetration	5.6, 9.102. 10.102	0 Min	0/60/90/120/180/240 min	
Special service conditions (e.g. exceptional condensation, heavy pollution, corrosive environment, fungus, small creatures. strong electric or magnetic	7.2, 8.5.4. 9.3.3 Table 7	No special service conditions	None	

fields, installation near highly sensitive IT equipment, explosion hazards, defined performances under fire conditions, heavy vibration and shocks, earthquakes, special mechanical loads, high repetitive overcurrent)				
<b>Installation method</b>				
Type	3.3, 5.6	Manufacturer's standard	Horizontal/Vert. edgewise/flatwise	
Maximum overall dimensions and weight	5.6, 6.2.1	Manufacturer's standard. according to application	None	
External conductor type(s)	8.8	Manufacturer's standard	Cable/BTS	
Direction(s) of external conductors	8.8	Manufacturer's standard	None	
External conductor material	8.8	Copper	Cu/Al	
External phase conductor, cross sections, and terminations	8.8	As defined within the standard	None	
External PE, N, PEN conductors cross sections, and terminations	8.8	As defined within the standard	None	
Special terminal identification requirements	8.8	Manufacturer's standard	None	
<b>Storage and handling</b>				
Maximum dimensions and weight of transport units	6.2.2 10.2.5	Manufacturer's standard	None	
Methods of transport (e.g. forklift, crane)	6.2.2, 8.1.6	Manufacturer's standard	None	
Environmental conditions different from the service conditions	7.3	As Service Condition	None	
Packing details	6.2.2	Manufacturer's standard	None	

<b>Operating arrangements</b>				
Isolation of external outgoing circuits	8.5.2	Manufacturer's standard	None	
<b>Maintenance and upgrade capabilities</b>				
Accessibility in service by ordinary persons: requirement to operate devices or change components while the BTS is energised	8.4.6.1	Basic protection	None	
Accessibility for inspection and similar operations	8.4.6.2.2	No requirements for accessibility	None	
Accessibility for maintenance in Service by authorized persons	8.4.6.2.3	No requirements for accessibility	None	
Accessibility for extension in service by authorized persons	8.4.6.2.4	No requirements for accessibility	None	
Method of functional units connection	8.5.1, 8.5.2	Manufacturer's standard	Fixed/disconnectable	
Protection against direct contact with hazardous live internal parts during maintenance or upgrade (e.g. functional units, main busbars, distribution busbars)	8.4	No requirements	None	
<b>Current carrying capability</b>				
Rated current of the BTS $I_{nA}$ (A)	3.8.9.1, 5.3, 8.4.3.2.3, 8.5.3, 8.8, 10.10.2, 10.10.3, 10.11.5	Manufacturer's standard, according to application	None	
Significant harmonic currents	5.3.1, 5.3.2	Manufacturer's standard, according to application	None	
Phase conductors characteristics / voltage drop	5.101, Annex BB	Manufacturer's standard	None	
Rated current of circuits	5.3.2	Manufacturer's	None	

$I_{nc}$ (A)		standard, according to application		
Rated diversity factor	5.4, 10.10.2.3	For BTS and tap-off units with single outgoing circuits: 1, For tap-off units with multiple outgoing circuits: see Table 101	None	
Ratio of cross section of the neutral conductor. to phase conductors up to and including 16 mm <sup>2</sup>	8.6.1	100%	None	
Ratio of cross section of the neutral conductor to phase conductors above 16 mm <sup>2</sup>	8.6.1	50% (min. 16 mm <sup>2</sup> )	None	

**Design verification**  
**Table I-4 Design verifications of bus bar trunking/rising mains**

S.No.	Characteristic to be verified	Sub-clauses of IEC 61439-6	Verification options available		
			Testing	Comparison with a reference design	Assessment
1	Strength of material and parts:	10.2.2	YES	NO	NO
	Resistance to corrosion				
	Properties of insulating materials:	10.2.3.1	YES	NO	NO
	Thermal stability				
	Resistance to abnormal heat and fire due to internal electric effects	10.2.3.2	YES	NO	YES
	Resistance to ultra-violet (UV) radiation	10.2.4	YES	NO	YES
	Lifting	10.2.5	YES	NO	NO
	Mechanical impact	10.2.6	YES	NO	NO
	Marking	10.2.7	YES	NO	NO
	Ability to withstand mechanical loads	10.2.101	YES	NO	NO
Thermal cycling test	10.2.102	YES	NO	NO	
2	Degree of protection of enclosures	10.3	YES	NO	YES
3	Clearances	10.4	YES	NO	NO
4	Creepage distances	10.4	YES	NO	NO
5	Protection against electric shock and integrity of protective circuits:	10.5.2	YES	NO	NO
	Effective continuity between the exposed conductive parts of the BTS and the protective circuit				
	Short-circuit withstand strength of the protective circuit	10.5.3	YES	YES	NO
6	Incorporation of switching devices and components	10.6	NO	NO	YES
7	Internal electrical circuits and connections	10.7	NO	NO	YES
8	Terminals for external conductors	10.8	No	NO	YES
9	Dielectric properties:	10.9.2	YES	NO	NO
	Power-frequency withstand voltage				
	Impulse withstand voltage	10.9.3	YES	NO	YES
10	Temperature-rise limits	10.10	YES	YES	NO
11	Short-circuit withstand strength	10.11	YES	YES	NO
12	Electromagnetic compatibility (EMC)	10.12	YES	NO	YES
13	Mechanical operation	10.13	YES	NO	NO
14	Resistance to flame propagation	10.101	YES	NO	NO
15	Fire resistance in building penetration	10.102	YES	NO	NO

**Note:** Verification by tested shall precede the verification by other two methods.

## APPENDIX J

### SAMPLE CALCULATION FOR REQUIREMENT OF LOGHTNING PROTECTION SYSTEM AND MEASURES

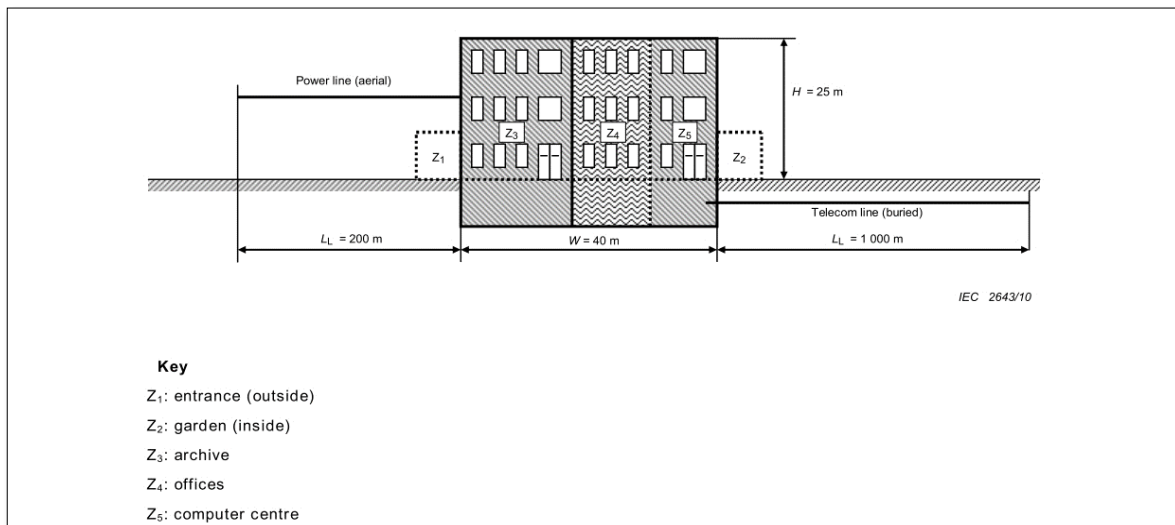
#### J-1 Office building

As a second case study, an office building with an archive, offices and a computer centre is considered (Figure J.1).

Loss of human life (L1) and economic loss (L4) are relevant for this type of structure.

It is required to evaluate the need for protection. This implies the determination of only the risk  $R_1$  for loss of human life (L1) with the risk components  $R_A$ ,  $R_B$ ,  $R_u$  and  $R_v$  (according to Table 2) and to compare it with the tolerable risk  $R_T = 10^{-5}$  (according to Table 4 as per IEC 62305-2). Suitable protection measures will be selected to reduce the risk to or below the tolerable risk.

Following the decision taken by the owner an economic evaluation is not requested; therefore the risk  $R_4$  for economic loss (L4) is not considered.



**FIGURE FIG J-1 - OFFICE BUILDING**

#### J-2 Relevant data and characteristics

The office building is located in flat territory without any neighbouring structures. The lightning flash density is  $N_G = 4$  flashes per  $\text{km}^2$  per year.

Data for the building and its surroundings are given in Table J-1.

Data for the incoming lines and their connected internal systems are given for the power line in Table J-2 and for the telecom line in Table J-3.

**Table J-1 Office building: Environment and structure characteristics**

Input parameter	Comment	Symbol	Value	Reference (As per IEC 62305-2)
Ground flash density ( $1/\text{km}^2/\text{year}$ )		$N_G$	4,0	
Structure dimensions (m)		$L, W, H$	20,40,25	
Location factor of structure	Isolated structure	$C_D$	1	Table A.1
LPS	None	$P_B$	1	Table B.2
Equipotential bonding	None	$P_{EB}$	1	Table B.7
External spatial shield	None	$K_{S1}$	1	Equation (B.5)

**Table J-2 — Office building: Power line**

Input parameter	Comment	Symbol	Value	Reference(As per IEC 62305-2)
Length (m)		$L_L$	200	
Installation factor	Aerial	$C_1$	1	Table A.2
Line type factor	LV line	$C_T$	1	Table A.3
Environmental factor	Rural	$C_E$	1	Table A.4
Shield of line (S2/km)	Unshielded	$R_s$	—	Table B.8
Shielding, grounding, isolation	None	$CLD$	1	Table B.4
		$C_{LI}$	1	
Adjacent structure	None	$L W$	—	
Location factor of adjacent	None	$C_{DJ}$	—	Table A.1
Withstand voltage of internal system (kV)		$U_w$	2,5	
	Resulting parameters	$K_{S4}$	0,4	Equation (B.7)
		$P_{ip}$	1	Table B.8
		$P_{si}$	0,3	Table B.9

**Table J-3 — Office building: Telecom line**

Input parameter	Comment	Symbol	Value	Reference (As per IEC 62305-2)
Length (m)		$L_L$	1 000	
Installation factor	Buried	$c_i$	0,5	Table A.2
Line type factor	Telecom line	$C_T$	1	Table A.3
Environmental factor	Rural	$C_E$	1	Table A.4
Shield of line (Wkm)	Unshielded	$R_s$	—	Table B.8
Shielding, grounding, isolation	None	$CLD$	1	Table B.4
		$CLI$	1	
Adjacent structure	None	$L W$	—	
Location factor of adjacent	None	$C_{DJ}$	—	Table A.1
Withstand voltage of internal system (kV)		$U_w$	1,5	
	Resulting parameters	$K_{S4}$	0,67	Equation (B.7)
		$P_{ip}$	1	Table B.8
		$P_{si}$	0,5	Table B.9

**J-3 Definition of zones in the office building**

The following zones are defined:

Z<sub>1</sub> (entrance area outside);

Z<sub>2</sub> (garden outside);

Z<sub>3</sub> (archive);

Z<sub>4</sub> (offices);

Z<sub>5</sub> (computer centre);

taking into account that:

- the type of surface is different in the entrance area outside, the garden outside and inside the structure;

- the structure is divided into two separate fireproof compartments: the first is the archive ( $Z_3$ ) and the second is the offices together with the computer centre ( $Z_4$  and  $Z_5$ );
- in all inner zones,  $Z_3$ ,  $Z_4$  and  $Z_5$ , internal systems connected to power as well as to telecom lines exist;
- no spatial shields exist.

In the different zones inside and outside the office building a total number of 200 persons shall be considered.

The number of persons related to each zone is different. The distribution into the individual zones is shown in Table J-4. These values are used later to subdivide the total loss values into fractions for each zone.

**Table J-4— Office building: Distribution of persons into zones**

Zone	Number of persons	Time of presence
$Z_1$ (entrance outside)	4	8 760
$Z_2$ (garden outside)	2	8 760
$Z_3$ (archive)	20	8 760
$Z_4$ (offices)	160	8 760
$Z_5$ (computer centre)	14	8 760
Total	$n_t = 200$	-

Following the evaluation by the lightning protection designer, the typical mean values of relative amount of loss per year relevant to risk  $R_1$  (see Table C.1 as per IEC 62305-2) for the whole structure are

- $L_T = 10^{-2}$  (outside the structure),
- $L_T = 10^{-2}$  (inside the structure),
- $L_F = 0,02$  classified as "commercial building".

These global values were reduced for each zone according to the number of people endangered in the individual zone related to the total number of people considered.

The resulting characteristics of the zones  $Z_1$  to  $Z_5$  are given in the Tables J-5 to J-9.

**Table J-5 — Office building: Factors valid for zone  $Z_1$  (entrance area outside)**

Input parameter	Comment	Symbol	Value	Reference (As per IEC 62305-2)
Ground surface	Marble	$r_i$	$10^{-3}$	Table C.3
Protection against shock	None	$P_{TA}$	1	Table B.1
Risk of fire	None	$r_f$	0	Table C.5
Fire protection	None	$r_P$	1	Table C.4
Internal spatial shield	None	$K_{S2}$	1	Equation (B.6)
L1: Loss of human life	Special hazard: None	$h_z$	1	Table C.6
	D1: due to touch and step	$L_T$	$10^{-2}$	Table C.2
	D2: due to physical damage	$L_F$	—	
	D3: due to failure of internal	$L_o$	-	
Factor for persons in zone	$n_z/n_t \times t_z/8\ 760 = 4/200 \times 8\ 760/8\ 760$	-	0,02	

**Table J-6 — Office building: Factors valid for zone Z2 (garden outside)**

Input parameter	Comment	Symbol	Value	Reference (As per IEC 62305-2)
Ground surface	Grass	$r_t$	$10^{-2}$	Table C.3
Protection against shock	Fence	$P_{TA}$	0	Table B.1
Risk of fire	None	$r_f$	0	Table C.5
Fire protection	None	$r_P$	1	Table C.4
Internal spatial shield	None	$K_{S2}$	1	Equation
L1: Loss of human life	Special hazard: None	$h_z$	1	Table C.6
	D1: due to touch and step	$L_T$	$10^{-2}$	Table C.2
	D2: due to physical damage	$L_F$	—	
	D3: due to failure of internal	$L_o$	—	
Factor for persons in zone	$n_z/n_t \times t_z/8\ 760 = 2/200 \times 8\ 760/8\ 760$	—	0,01	

**Table J-7 — Office building: Factors valid for zone Z3 (archive)**

Input parameter	Comment	Symbol	Value	Reference (As per IEC 62305-2)	
Type of floor	Linoleum	$r_t$	$10^{-5}$	Table C.3	
Protection against shock (flash to structure)	None	$P_{TA}$	1	Table B.1	
Protection against shock (flash to line)	None	$P_{TU}$	1	Table B.6	
Risk of fire	High	$r_f$	$10^{-f}$	Table C.5	
Fire protection	None	$r_P$	1	Table C.4	
Internal spatial shield	None	$K_{S2}$	1	Equation	
Power	Internal wiring	Unshielded (loop conductors in the same conduit)	$K_{S3}$	0,2	Table B.5
	Coordinated SPDs	None	$P_{SPD}$	1	Table B.3
Telecom	Internal wiring	Unshielded (large loops >10m2)	$K_{S3}$	1	Table B.5
	Coordinated SPDs	None	$P_{SPD}$	1	Table B.3
L1: Loss of human life	Special hazard: low panic	$h_z$	2	Table C.6	
	D1: due to touch and step	$L_T$	$10^{-2}$	Table C.2	
	D2: due to physical damage	$L_F$	0,02		
	D3: due to failure of internal	$L_o$	—		
Factor for endangered persons	$n_z/n_t \times t_z/8\ 760 = 20/200 \times 8\ 760/8\ 760$	—	0,10		

**Table J-8 — Office building: Factors valid for zone Z4 (offices)**

Input parameter		Comment	Symbol	Value	Reference (As per IEC 62305-2)
Type of floor		Linoleum	$r_f$	$10^{-5}$	Table C.3
Protection against shock (flash to structure)		None	$P_{TA}$	1	Table B.1
Protection against shock (flash to line)		None	$P_{TU}$	1	Table B.6
Risk of fire		Low	$r_f$	$10^{-3}$	Table C.5
Fire protection		None	$r_P$	1	Table C.4
Internal spatial shield		None	$K_{S2}$	1	Equation (B.6)
Power	Internal wiring	Unshielded (loop conductors in the same conduit)	$K_{S3}$	0,2	Table B.5

Input parameter		Comment	Symbol	Value	Reference (As per IEC 62305-2)
	Coordinated SPDs	None	$P_{SPD}$	1	Table B.3
Telecom	Internal wiring	Unshielded (large loops > 10	$K_{S3}$	1	Table B.5
	Coordinated SPDs	None	$P_{SPD}$	1	Table B.3
L1: Loss of human life	Special hazard: low panic		$h_z$	2	Table C.6
	D1: due to touch and step		$L_T$	$10^{-2}$	Table C.2
	D2: due to physical damage		$L_F$	0,02	
	D3: due to failure of internal		$L_o$	—	
Factor for persons in zone		$n_z/n_t \times t_z/8\ 760 = 160/200 \times 8\ 760/8\ 760$	—	0,80	

**Table J-9 — Office building: Factors valid for zone Z5 (computer centre)**

Input parameter		Comment	Symbol	Value	Reference (As per IEC 62305-2)
Type of floor		Linoleum	$r_f$	$10^{-5}$	Table C.3
Protection against shock (flash to structure)		None	$P_{TA}$	1	Table B.1
Protection against shock (flash to line)		None	$P_{TU}$	1	Table B.6
Risk of fire		Low	$r_f$	$10^{-3}$	Table C.5
Fire protection		None	$r_P$	1	Table C.4
Internal spatial shield		None	$K_{S2}$	1	Equation (B.6)
Power	Internal wiring	Unshielded (loop conductors in the same conduit)	$K_{S3}$	0,2	Table B.5
	Coordinated SPDs	None	$P_{SPD}$	1	Table B.3
Telecom	Internal wiring	Unshielded (large loops > 10 m <sup>2</sup> )	$K_{S3}$	1	Table B.5
	Coordinated SPDs	None	$P_{SPD}$	1	Table B.3
L1: Loss of human life	Special hazard: low panic		$h_z$	2	Table C.6
	D1: due to touch and step		$L_T$	$10^{-2}$	Table C.2
	D2: due to physical damage		$L_F$	0,02	
	D3: due to failure of internal		$L_o$	—	
Factor for persons in zone		$n_z/n_t \times t_z/8\ 760 = 14/200 \times 8\ 760/8\ 760$	—	0,07	

#### J-4 Calculation of relevant quantities

Calculations are given in Table J-10 for the collection areas and in Table J-11 for the expected number of dangerous events.

**Table J-10— Office building: Collection areas of structure and lines**

	Symbol	Result m <sup>2</sup>	Reference Equation	Equation
Structure	$A_D$	$2,75 \times 10^4$	(A.2)	$A_D = L \times W + 2 \times (3 \times H) \times (L + W) + 7 \times E \times (3 \times H)^2$
	$A_M$	—	(A.7)	Not relevant
Power line	$A_{LP}$	$8,00 \times 10^3$	(A.9)	$A_{LP} = 40 \times L_L$
	$A_{IP}$	$8,00 \times 10^5$	(A.11)	Not relevant
	$A_{DAP}$	0	(A.2)	No adjacent structure
Telecom line	$A_{LT}$	$4,00 \times 10^4$	(A.9)	$A_{LP} = 40 \times L_L$
	$A_{IT}$	$4,00 \times 10^6$	(A.11)	Not relevant
	$A_{DAT}$	0	(A.2)	No adjacent structure

**Table J-11 - Office building: Expected annual number of dangerous events**

	Symbol	Result 1/year	Reference Equation	Equation
Structure	$N_D$	$1,10 \times 10^{-1}$	(A.4)	$N_D = N_G \times A_D \times C_D \times 10^{-6}$
	$N_M$	—	(A.6)	Not relevant
Power line	$N_{LP}$	$3,20 \times 10^{-2}$	(A.8)	$N_{LP} = N_G \times A_{LP} \times C_{IP} \times C_{TP} \times 10^{-6}$
	$N_{IP}$	3,20	(A.10)	Not relevant
	$N_{DAP}$	0	(A.5)	No adjacent structure
Telecom line	$N_{LT}$	$8,00 \times 10^{-2}$	(A.8)	$N_{LT} = N_G \times A_{LT} \times C_{IT} \times C_{ET} \times C_{TT} \times 10^{-6}$
	$N_{IT}$	8,00	(A.10)	Not relevant
	$N_{DAT}$	0	(A.5)	No adjacent structure

#### J-5 Risk $R_1$ - Decision on need for protection

Values of the risk components for the unprotected structure are reported in Table J-12.

**Table J-12 - Office building: Risk  $R_1$  for the unprotected structure**  
(values  $\times 10^{-5}$ )

Type of damage	Symbol	$Z_1$	$Z_2$	$Z_3$	$Z_4$	$Z_5$	Structure
D1 Injury due to shock	$R_A$	0,002	0	= 0	0,001	= 0	<b>0,003</b>
	$R_u = R_{U/P} + R_{U/T}$			= 0	0,001	= 0	<b>0,001</b>
D2 Physical damage	$R_B$			4,395	0,352	0,031	<b>4,778</b>
	$R_v = R_{V/P} + R_{V/T}$			4,480	0,358	0,031	<b>4,870</b>
<b>Total</b>		<b>0,002</b>	<b>0</b>	<b>8,876</b>	<b>0,712</b>	<b>0,062</b>	<b><math>R_I = 9,65</math></b>
<b>Tolerable</b>		<b><math>R_1 &gt; R_T</math>: Lightning protection is required</b>					<b><math>R_T = 1</math></b>

Because  $R_1 = 9,65 \times 10^{-5}$  is higher than the tolerable value  $R_T = 10^{-5}$ , lightning protection for the structure is required.

### J-6 Risk $R_1$ - Selection of protection measures

The risk  $R_1$  in the structure is mainly concentrated in zone  $Z_3$  due to physical damages caused by lightning striking the structure or the connected lines (components  $R_B = 49\%$  and  $R_v = 50\%$  together cover 99% of the total risk) (see Table J-12).

These dominant risk components can be reduced by:

- providing the whole building with an LPS conforming to IEC 62305-3 reducing component  $R_B$  via probability  $P_B$ . Lightning equipotential bonding at the entrance - a mandatory requirement of the LPS - reduces also the components  $R_u$  and  $R_v$  via probability  $P_{EB}$ ;
- providing zone  $Z_3$  (archive) with protection measures against the consequences of fire (such as extinguishers, automatic fire detection system etc.). This will reduce the components  $R_B$  and  $R_v$  via the reduction factor  $r_p$ ;
- providing lightning equipotential bonding conforming to IEC 62305-3 at the entrance of the building. This will reduce only the components  $R_u$  and  $R_v$  via probability  $P_{EB}$ .

Combining different elements of these protective measures the following solutions could be adopted:

#### **Solution a)**

- Protect the building with a Class III LPS conforming to IEC 62305-3, to reduce component  $R_B$  ( $P_B = 0,1$ ).
- This LPS includes the mandatory lightning equipotential bonding at the entrance with SPDs designed for LPL III ( $P_{EB} = 0,05$ ) and reduces components  $R_u$  and  $R_v$ .

#### **Solution b)**

- Protect the building with a Class IV LPS conforming to IEC 62305-3, to reduce component  $R_B$  ( $P_B = 0,2$ ).
- This LPS includes the mandatory lightning equipotential bonding at the entrance with SPDs designed for LPL IV ( $P_{EB} = 0,05$ ) and reduces components  $R_u$  and  $R_v$ .
- Use fire extinguishing (or detection) systems to reduce components  $R_B$  and  $R_v$ . Install a manual system in the zone  $Z_3$  (archive) ( $r_p = 0,5$ ).

For both solutions, the risk values from Table J-12 will change to the reduced values reported in Table J-13.

**Table J-13 - Office building: Risk  $R_1$  for the protected structure (values x  $10^{-5}$ )**

	$Z_1$	$Z_2$	$Z_3$	$Z_4$	$Z_5$	Total	Tolerable	Result
Solution a)	=0	0	0,664	0,053	0,005	$R_1 = 0,722$	$R_T = 1$	$R_1 \leq R_T$
Solution b)	=0	0	0,552	0,089	0,008	$R_2 = 0,648$	$R_T = 1$	$R_2 \leq R_T$

Both solutions reduce the risk below the tolerable value. The solution to be adopted is subject to both the best technical criteria and the most cost-effective solution.

**APPENDIX K**

**Method of Test Sampling for Electrical items**

Sr No	Description	IS Code	Test								
			Sampling of Cables								
1	PVC Insulated Copper Conductor Wires	IS 694: 2010	Number of Drums/Coils/ Reels in the Lot (N) (1)	Number of Drums/Coils/Reels to be Taken as Sample (n) (2)	Permissible Number of Defectives (a) (3)						
			Up to 50	3	0						
			51-100	5	0						
			101-300	8	0						
			301 and above	13	1						
2	Conduit (Steel and Accessories	IS 9537 (Part 2)-1981	<b>SAMPLE SIZE, ACCEPTANCE AND REJECTION NUMBER</b>								
			Lot Size	Stage of Sample	For Dimensional requirements			For other Acceptance Tests			
					Sample Size	Acceptance Number	Rejection Number	Sample Size	Acceptance Number	Rejection Number	
			(1)	(2)	(3)	(4)	(5)	(6)	(7)	(8)	
			Up to 300	First	8	0	2	3	0	2	
				Second	8	1	2	3	1	2	
			301 to 500	First	13	0	2	5	0	2	
				Second	13	1	2	5	1	2	
			501 to 1000	First	20	0	3	8	0	2	
				Second	20	3	4	8	1	2	
			1001 and above	First	32	1	5	13	0	3	
				Second	32	4	4	13	3	4	
			3	Conduit (PVC) and Accessories	IS : 9537 (Part 3) - 1983	<b>Sampling of Cables</b>					
Lot Size	For Dimensional requirements					Other Acceptance Tests					
	Sample Size	Permissible No. of Defectives									
(1)	(2)	(3)				(4)					
Up to 300	13	0				4					
301 ,, 500	20	0				3					
501 ,, 1000	32	1		4							

			1001,,3000	50	2	5
			3001 and above	80	3	7
4	Wiring : Switches And Accessories	IS 3854:1997	<b>Sampling Plan</b>			
			<b>Lot Size</b>	<b>N1</b>	<b>N2</b>	<b>(N1+N2)</b>
			<b>(1)</b>	<b>(2)</b>	<b>(3)</b>	<b>(4)</b>
			<b>C1</b>	<b>C2</b>		
			<b>(5)</b>	<b>(6)</b>		
			51 to 100	10	20	30
			101 to 200	13	26	39
			201 to 300	20	40	60
			301 to 500	25	50	75
			501 to 800	35	70	105
			801 to 1300	50	100	150
			1300 and above	75	150	225
			NOTE - The plan recommended in this table assures that lots with defective 4 percent or less would be accepted most of the time, and lots with defectives 25 percent and above would be rejected most of the time. The exact consumer risk depends on the lot size and it would be minimum when the lot size is maximum.			
5	3 mm thick phenolic laminated sheet	IS 2036:1995	<b>Scale of Sampling</b>			
			<b>Lot Size (No. of Packages)</b>	<b>Number of packages selected in a sample</b>		
			<b>(1)</b>	<b>(2)</b>		
			Up to 150	3		
			151-500	4		
			101 and above	5		
6	Industrial type pressure gauges with gun metal / brass valves	PM-IS-15100.pdf	<b>Scale of Sampling</b>			
			<b>SI No.</b>	<b>Lot Size</b>	<b>Sample Size</b>	
			<b>(1)</b>	<b>(2)</b>	<b>(3)</b>	
			(i)	Up to 500	10	
			(ii)	501 to 3200	14	
			(iii)	3201 to 10000	20	
			(iv)	10001 to 35000	32	

			(v)	35001 and above	50
7	Motorized Butter fly Valves with CI Body, SS Disc,O - ring and minimum PN-16 pressure rating , conforming to BS 5155, IS 13095, with IP-55 actuator as specified	PM/ IS 13095/1, February 2019	<b>Test Durations</b>		
			<b>Nominal Dia mm</b>	<b>Minimum Test Duration in Minutes for</b>	
				<b>Body Test</b>	<b>Seat Test When Applicable</b>
			Up to and including 50	0.25	0.25
			65 to 150	1	1
			200 to 300	2	2
			350 to 1000	5	2
			1200 to 2000	5	3
			NOTE — During the body test, there shall be no leakage through the metal end joints or the valve shaft seal, nor shall any part be permanently deformed.		

# APPENDIX - L

Advisory

**Central Public Works Department**  
**OFFICE MEMORANDUM**  
**No. DG/SE(E)TAS/SPECIFICATIONS/06**  
**ISSUED BY AUTHORITY OF DIRECTOR GENERAL, CPWD**  
**Nirman Bhawan, New Delhi – 110011**

---

Dated 30.11.2021

**Sub: - Advisory for proper selection of design in respect of power distributions in residential/ Non-residential Buildings to optimize number of conduits in the slab.**

The issue of large number of conduits in the slab for wiring, especially near the distribution boards affecting the laying of RCC slab has been noticed. Hence, there is need of adopting proper design for power distribution ensuring optimized conduit layout for which following advisory is issued:

1. CPWD General Specification for Electrical Works Part- 1 Internal EI provides for flexibility in selection of conduits as given in Table-1, in Chapter-4. Proper selection of conduit size needs to be ensured to minimize the number of conduits accordingly.

Based on the same, the conduit layouts for slabs to be laid should be prepared well in advance before laying of slab by the firm and be submitted to the department. It should be approved by Engineer-in-Charge (E) in consultation with EE (C) in-charge and issued to firm for execution.

(NOTE: Above condition may be included in the NIT for works including EPC contract, if not already done)

2. Typical layouts are prepared for reference and guidance as per following:

- a. Typical conduit layouts for sample Type III, IV, V and VI
- b. Typical layout for switch and socket arrangements for geysers in bathroom are prepared.
- c. Typical layout for twin control for fan and light points in bedrooms.

3. Power distribution design should be planned so as to ensure optimized number of conduits at the DB and in slab. If required, sub distribution boards of appropriate size and capacity shall be provided in addition. Powder coated double door DBs having aesthetic design are available and can be used in the corridor/ rooms/ lobby as required.

4. In non-residential buildings, especially multi storied ones, the DBs are generally provided in the rising main shafts. Optimizing number of rising main's shafts/ DB locations shall be useful in reducing the concentration of conduits, since there shall be more number of distribution boards, each having lesser number of conduits then.

5. In multi storied non-residential building having multiple E&M services like FAS, EPBAX, LAN, BMS, CCTV etc., the shafts for these services may be planned in a manner to keep them segregated from the power distribution shafts/ rising mains to avoid high concentration of conduits in same location/ slab.

6. Wherever false ceiling provision exists in non-residential building, the conduits can be laid on surface above false ceiling instead of in slab.

7. The location of the loop points/ junction boxes for conduits should be planned keeping in consideration the aesthetics of the room and be preferably at the corners or edges of the wall.

The above issues with the approval of DG, CPWD.

Executive Engineer (E) TAS

To,

1. All SDGs, ADGs CEs and SEs of CPWD/PWD Delhi with the request to bring into notice of all concerned. **(Through Website Only)**

Executive Engineer (E) TAS

**Note: The above advisory containing the Typical layouts for following is uploaded on CPWD website on 30.11.2021 with colored drawings (12 nos.) and may be seen on website for reference:**

- a) Typical conduit layouts for sample Type III, IV, V and VI
- b) Typical layout for switch and socket arrangements for geysers in bathroom are prepared.
- c) Typical layout for twin control for fan and light points in bedrooms.

**CHAPTER 18**  
**LIST OF TABLES**  
**TABLE 1**

**Tripping Characteristics of MCBs**

Based on the tripping characteristics, MCBs are available in 'B' and 'C' curve to suit different types of applications.
<b>'B' Curve:</b> For protection of electric circuits with equipment that does not cause surge current (lighting and socket outlet circuits)
Short circuit release is set to 3 - 5 $I_n$
<b>'C' Curve:</b> For protection of electric circuits with equipment that cause surge current (inductive and motor circuits) eg. Air conditioner, motors etc.
Short circuit release is set to 5 - 10 $I_n$
<b>'D' Curve:</b> For protection of electric circuits which cause high in rush current when they are switched ON, typically 15 times the normal running current (Transformers, Heavy Start Motors, 2 PoleMotors) for eg. UPS, SMPS etc.
Short circuit release is set to 10 - 20 $I_n$

**TABLE 2**  
**Duty Category of Switches**

<b>Utilization Category</b>	<b>Typical Applications</b>
AC20/DC20	<p>Connecting and disconnecting under no-load.</p> <p>Assumes all switching operations are carried out by other applicable devices before this device is operated.</p>
AC21/DC21	<p>Switching of resistive loads including moderate overloads.</p> <p>Suitable for purely resistive type loads.</p> <p>Device can switch 150% of its rated current under fault conditions.</p>
AC22/DC22	<p>Switching of mixed resistive/ inductive loads, including moderate overloads</p> <p>Suitable for mixed resistive/inductive loads. Device can switch 300% of its rated current under fault conditions.</p>
AC23/DC23	<p>Switching of highly inductive loads.</p> <p>Devices complying with AC23/DC23 are provided mainly as backup to other means of switching. Eg. Contacts. In the event of failure of functional devices, an AC23/DC23 type device can safely interrupt a stalled motor current. Where devices are the only means of controlling individual motors, they should comply with the requirements of Appendix A of the standard.</p>

**TABLE 3**  
**Class of Insulation (For Electric Motors)**

Type	Max. Operating Temp.	Materials Used
Y	90°C	Cotton, silk, paper, and similar organic material and combination of such material which are not (impregnated) nor immersed in oil.
A	105°C	Above materials impregnated with Varnish or enamel or oil immersed.
E	120°C	Comprise inorganic materials such as mica, glass fibre as best os or combination of the sematerial\s inbuilt up form with binding cement.
B	130°C	
F	155°C	Class B materials when built up with suitable cement or binder.
H	180°C	Consists of materials or combination of materials such as mica, glass fiber Silicon lastomer with suitable winding, impregnating or coating substances as silicon resins.
C	Above 180°C	Materials such as mica Porcelain, glass quartz and asbestos with or without an inorganic binder.

**TABLE 4  
Fire Protection**

<b>Class of Fire</b>	
Class A	: Fires involving Paper, Wood, Textile, Packing materials and the like.
Class B	: Fires involving Oil, Petrol, Solvent, Grease, Paints, Celluloid and the like.
Class C	: Fires involving Electrical Hazards, Motor Vehicle Gaseous substance under pressure.
Class D	: Fires involving Chemicals, Metal and active like.
Class E	: Fires involving Electrical equipment, Delicate machinery and the like.

<b>Mode of Fire Protection</b>			
1.	Sand/Water buckets	7.	Fire Dampers in AC Ducts
2.	Dry/ Wet Hydrant risers	8.	Fire Doors with fusible link
3.	Heat/Smoke Detectors	9.	Pressurization Plant
4.	Automatic/ Manual Fire Alarm	10.	Public Address System
5.	Sprinklers	11.	Fire Escapes/ External Stairs
6.	Lightning Conductors		

<b>Coverage (Floor) Area</b>					
1.	Water/ Sand Bucket	100 sq.mt.	4.	Sprinklers	6 sq.mt.
2.	Extinguishers (9lts)	600 sq.mt.	5.	Heat Detectors	16 sq.mt.
3.	Hydrant Riser (Outlet 100 mm dia with landing valve and first aid hose reel)	100 sq.mt. 930sq.mt.	6.	Smoke Detectors (For a ceiling height of 3 mts. and clean environment)	50 sq.mt.

<b>Choice of Extinguishers</b>		
S. No.	Type of Extinguishers	Suitable for Class of Fire
1.	Soda Acid Type	Class -A
2.	Foam Type	Class -B
3.	Dry Chemical Powder Type	Class - B, C, D &E
4.	Carbon-di-oxide Type	Class - B, C &E
5.	Water Carbon-di-oxide Type	Class -A
6.	Carbo-Tetra-Chloride Type	Class -C

<b>Water Requirement for the Fire Fighting</b>	
Q = 3000P	Q = Fire demand in Liters/Minutes P = Population in Thousands

**Note:** The above rate must be maintained at a minimum pressure of 1 to 1.5 kg / cm<sup>2</sup> for at least four hours.

**TABLE 5**  
**Degrees of Protection**

Degrees of Protection to DIN 40 050 and to IEC 144

The degree of protection is specified in accordance with DIN 40 050 and with Publications of the International Electro-technical Commission (IEC) by means of the letters IP (International Protection) and two characteristic numerals.		The first numeral indicates the degree of protection against contact with live parts and the ingress of foreign bodies; the second numeral indicates the degree of protection against water.	
First Characteristic Numeral	Degree of Protection	Second Characteristic Numeral	Degree of Protection
0	No protection of persons against contact with live or moving parts inside the enclosure. No protection of equipment against ingress of solid foreign bodies.	0	No protection
1	Protection against accidental or inadvertent contact with live or moving parts inside the enclosure body large surface of the human body as, for example, a hand, but no protection against deliberate access to such parts. Protection against ingress of large solid foreign bodies of diameters greater than 50 mm.	1	Protection against drops of condensate. Drops of condensate falling vertically on the enclosure shall have no harmful effect
2	Protection against contact with live or moving parts inside the enclosure by fingers.	2	Protection against drops of other liquids.
	Protection against ingress of medium size solid foreign bodies of diameters greater than 12 mm.		Drops of falling liquid shall have no harmful effect when the enclosure is tilted at any angle up to 15° from the vertical.
3	Protection against contact with live or moving parts inside the enclosure by tools, wires or such objects of thickness greater than 2.5 mm. Protection against ingress of small solid foreign bodies of diameters greater	3	Protection against rain: Water falling as rain at an angle equal to or less than 60° with respect to the vertical shall have no harmful effect.

	than 2.5 mm.		
4	Protection against contact with live or moving parts inside the enclosure by tools, wires or such objects of thickness greater than 1mm. Protection against ingress of small solid foreign bodies of diameters greater than 1 mm.	4	Protection against splashing liquid: Liquid splashed from any direction shall have no harmful effect
5	Complete protection against contact with live or moving parts inside the enclosure. Protection against harmful deposits of dust. The ingress of dust is not totally prevented, but dust cannot enter in an amount sufficient to interfere with the satisfactory operation of the equipment enclosed.	5	Protection against water-jets: Water projected by a nozzle from any direction under stated conditions shall have no harmful effect.
6	Complete protection against contact with live or moving parts inside the enclosure. Protection against ingress of dust.	6	Protection against conditions on ships decks (deck water tight equipment): Water due to heavy seas shall not enter the enclosures under prescribed conditions <sup>1</sup> .
		7	Protection against immersion in water: It must not be possible for water to enter the enclosure under stated conditions of pressure and time <sup>1</sup> .
		8	Protection against indefinite immersion in water under specified pressure: It must not be possible for water to enter the enclosure <sup>1</sup> .
1. For certain types of equipment there must be no ingress of water. Where required this is stated in a supplementary page for the equipment concerned.			

**TABLE 6**  
**Selection of Lamps**

<b>Lamp type</b>	<b>Range</b>	<b>Luminous flux</b>	<b>Efficacy (lm/W)</b>	<b>Average Life (hr)</b>	<b>Color Rendering (Ra)</b>
CFL	18W-36W	1200-2900	60-80	15000	75-85
Fluorescent					
T5	28W-54W	2900-4850	90-104	24000	80-90
T8	18W-36W	750-3250	50-90	20000	80-85
T12	20W-40W	950-2450	48-61	12000	50-75
Halogen	50W	1200	24	2000	75-90
Metal halide	70W-250W	5300-25000	76-100	12000	70-90
High pressure sodium vapor	70W-1000W	5600-130000	80-130	20000	20-65
Low pressure sodium vapor	55W-135W	8100-32000	100-230	20000	20-65
Induction lamp	70W-150W	6500-12000	80-95	100000	65-90
LED	3W-120W	750-14000	Min 100	80000	More than 80

**TABLE 7**  
**Capacitor Selection Chart**

Present Power Factor	Required Power Factor				
	0.85	0.90	0.95	0.98	Unity
0.50	1.112	1.248	1.403	1.529	1.732
0.55	0.899	1.035	1.190	1.316	1.519
0.60	0.714	0.849	1.005	1.131	1.334
0.65	0.549	0.685	0.840	0.966	1.169
0.70	0.400	0.536	0.691	0.811	1.020
0.75	0.262	0.398	0.553	0.673	0.882
0.80	0.130	0.266	0.421	0.541	0.750
0.85	-	0.136	0.291	0.417	0.620
0.90	-	-	0.155	0.281	0.484
0.95	-	-	-	0.126	0.329

Required KVAR = KW x Multiplying factor.

**TABLE 8**  
**Recommended Values of Illumination as per NBC Part 8 Section 1**  
**Building services Lighting and Natural Ventilation**

**Recommended Values of Illuminance**

Sl. No.	Types of Interior or Activity	Range of Service Illuminance in Lux	Quality Class of Direct Glare Limitation	Remarks
<b>1</b>	<b>AGRICULTURE AND HORTICULTURE</b>			
1.1	Inspection of farm products where Colour is important Other important tasks	300-500-750 200-300-500	1 2	Local lighting may be appropriate  Local lighting may be appropriate
<b>1.2</b>	<b>Farm workshops</b>			
1.2.1	General	50-100-150	3	
1.2.2	Workbench or machine	200-300-500	2	Local or portable lighting may be appropriate
1.3	Milk premises	50-100-150	3	
1.4	Sick Animal Pets, Calf Nurseries	30-50-100	3	
1.5	Other Firm and Horticulture Building	20-30-50	3	
<b>2</b>	<b>COAL MINING (SURFACEBUILDING)</b>			
<b>2.1</b>	<b>Coal preparation plant</b>			
2.1.1	Walkways, Floors, under converters	30-50-100	3	
2.1.2	Wagon loading, bunkers	30-50-100	3	
2.1.3	Elevators, Chute transfer pits, Washburn	50-100-150	3	
2.1.4	Drum filters, screen, rotating shafts	100-150-200	3	
2.1.5	Picking belts	150-200-300	3	Directional & colour properties of lighting may be important for easy recognition of coal & rock
<b>2.2</b>	<b>Lamp Rooms</b>			
2.2.1	Repair section	200-300-500	2	
2.2.2	Other areas	100-150-200	3	
2.3	Weight cabins, farmhouses	100-150-200	3	
2.4	Winding houses	100-150-200	3	

<b>3</b>	<b>ELECTRICITY GENERATION TRANSMISSION AND DISTRIBUTION</b>			
<b>3.1</b>	General plant			
3.1.1	Turbine houses (operating floor)	150-200-300	2	
3.1.2	Boiler and turbine house basements	50-100-150	3	
3.1.3	Boiler house, platforms, areas around Burners	50-100-150	3	
3.1.4	Switch rooms, meter/rooms, oil plant rooms, HV substations(indoor)	100-150-200	2	
3.1.5	Control room	200-300-500	1	Localized lighting of control display & the control desks may be appropriate
3.1.6	Relay and telecommunication rooms	200-300-500	2	
3.1.7	Diesel generator & compressor rooms	100-150-200	3	
3.1.8	Pump houses, water treatment plant Houses	100-150-200	3	
3.1.9	Battery rooms, charges, rectifiers	50-100-150	3	
3.1.10	Precipitator chambers, platforms, etc.	50-100-150	3	
3.1.11	Cable tunnels & basements, Circulating Water culverts & screen chamber	30-50-100	3	
<b>3.2</b>	<b>Coal Plant</b>			
3.2.1	Conveyors, gantries, junction towers, Unloading hoppers, ash handling plants, Setting pits, dust hoppers	50-100-150	3	
3.2.2	Other areas where operators may be Attendance	100-150-200	3	
<b>3.3</b>	<b>Nuclear Plants</b>			
	Gas circulation bays, reactor area, boiler platform, reactor charges and discharge face	100-150-200	2	
<b>4</b>	<b>METALMANUFACTURE</b>			
<b>4.1</b>	<b>Iron Making</b>			
4.1.1	Sinter Plant Plant Floor Mixer drum, fan house, screen houses, coolers, transfer stations	100-150-200 200-300-500	3 2	

4.1.2	Furnaces, cupola General Control Platforms Conveyor galleries, walkways	100-150-200 200-300-500 30-50-100	3 2 3	Local lighting may be appropriate
<b>4.2</b>	<b>Steel Making</b>			
4.2.1	Electric Melting Shops	150-200-300	3	
<b>4.2.2</b>	<b>Basic Oxygen Steel Making Plants</b>			
4.2.2.1	General	100-150-200	3	
4.2.2.2	Converter Floor, teeming bay	150-200-300	3	
4.2.2.3	Control Platforms	200-300-500	2	Local lighting may be appropriate
4.2.2.4	Scrap bays	100-150-200	3	
<b>4.3</b>	<b>Metal forming and treatment</b>			
4.3.1	Ingot stripping, soaking pits, annealing and heat treatment bays, acid recovery plant. Pickling and cleaning bays, roughing mills, cold mills, finishing mills, tinning and galvanizing lines, cut up and rewind line	150-200-300	3	
4.3.2	General	100-150-200	3	
4.3.3	Control Platforms	200-300-500	2	Local lighting may be appropriate
4.3.4	Wire mills, product finishing, steel inspection and treatment	200-300-500	3	
4.3.5	Plate/strip inspection	300-500-700	2	
4.3.6	Inspection of tin plate, stainless steel, etc.	-	-	Special lighting to reveal faults in the specular surface of the material will be required
<b>4.4</b>	<b>Foundries</b>		3	
<b>4.4.1</b>	<b>Automatic plant</b>			
4.4.1.1	Without manual operation	30-50-100	3	
4.4.1.2	With occasional manual operation	100-150-200	3	
4.4.1.3	With continuous manual operation	150-200-300	3	
4.4.1.4	Control room	200-300-500	1	Special lighting to reveal faults in the specular surface of the material will be required
4.4.1.5	Control Platforms	200-300-500	2	
<b>4.4.2</b>	<b>Non-automatic Plants</b>			
4.4.2.1	Charging floor, Pouring, Shaking Out, Cleaning, Grinding Feltin	200-300-500	3	

4.4.2.2	Rough moulding, rough core making	200-300-500	3	
4.4.2.3	Fine moulding, fine core making	300-500-750	2	
4.4.2.4	Inspection	300-500-750	2	
<b>4.5</b>	Forges (severe vibration is likely to occur)			
4.5.1	General	200-300-500	2	
4.5.2	Inspection	300-500-750	2	
<b>5</b>	<b>CERAMICS</b>			
<b>5.1</b>	Concrete Products Mixing, Casting, Cleaning	150-200-300	3	
<b>5.2</b>	<b>Potteries</b>			
5.2.1	Grinding, moulding, pressing, cleaning, Trimming, glazing, firing	200-300-500	3	
5.2.2	Enameling, colouring	500-750-1000	1	
<b>5.3</b>	<b>Glassworks</b>			
5.3.1	Furnace rooms, bending, annealing	100-150-200	3	
5.3.2	Mixing rooms, forming, cutting, grinding, Polishing, toughening	200-300-500	3	
5.3.3	Beveling, decorative cutting, etching, silvering	300-500-750	2	
5.3.4	Inspection	300-500-750	2	
<b>6</b>	<b>CHEMICALS</b>			
<b>6.1</b>	<b>Petroleum, chemical and petrochemical works</b>			
6.1.1	Exterior walkways, Platforms, stairs & ladders	30-50-100	3	
6.1.2	Exterior pump and valve areas	50-100-150	3	
6.1.3	Pump and compressor houses	100-150-200	3	
6.1.4	Process plant with remote control	30-50-100	3	
6.1.5	Process plant requiring occasional Manual interventions	50-100-150	3	
6.1.6	Permanently occupied work stations in Process plant	150-200-300	3	
6.1.7	Control rooms for process plant	200-300-500	1	
<b>6.2</b>	<b>Pharmaceutical manufacturer and fine chemicals manufacturer</b>			

6.2.1	Pharmaceutical Manufacturer Grinding, granulating, mixing, drying, tableting, sterilizing, washing, preparation of solutions, filling capping, wrapping, hardening	300-500-750	2	
<b>6.2.2</b>	<b>Fine chemical manufacture</b>			
6.2.2.1	Exterior walkways, platform, stairs and ladders	30-50-100	3	
6.2.2.2	Process plant	50-100-150	3	
6.2.2.3	Fine chemical finishing	300-500-750	2	
6.2.2.4	Inspection	300-500-750	1	Local lighting may be appropriate
<b>6.3</b>	<b>Soap Manufacture</b>			
6.3.1	General Area	200-300-500	2	
6.3.2	Automatic Processes	100-200-300	2	
6.3.3	Control panel	200-300-500	1	Local lighting may be appropriate
6.3.4	Machines	200-300-500	2	
<b>6.4</b>	<b>Paintworks</b>			
6.4.1	General	200-300-500	2	
6.4.2	Automatic Processes	150-200-300	2	
6.4.3	Control Panel	200-300-500	2	
6.4.4	Special Batch mixing	500-750-1000	2	
6.4.5	Color Matching	750-1000-1500	1	
<b>7</b>	<b>MECHANICAL ENGINEERING</b>			
<b>7.1</b>	<b>Structural Steel Fabrication</b>			
7.1.1	General	200-300-500	3	
7.1.2	Marking off	300-500-750	3	Local lighting may be appropriate
<b>7.2</b>	<b>Sheet Metal Works</b>			
7.2.1	Pressing ,punching, shearing, stamping, spinning, folding	300-500-750	2	
7.2.2	Bench work, scribing, inspection	500-750-1000	2	
<b>7.3</b>	<b>Machine and tool shops</b>			
7.3.1	Rough bench and machine work	200-300-500	3	
7.3.2	Medium bench and machine work	300-500-750	2	
7.3.3	Fine bench and machine work	500-750-1000	2	
7.3.4	Gauge rooms	750-1000-1500	1	Optical aids may be required
<b>7.4</b>	<b>Die Sinking Shops</b>			
7.4.1	General	300-500-750	2	
7.4.2	Fine Works	1000-1500-2000	1	Flexible Local lighting is desirable

<b>7.5</b>	<b>Welding and soldering shops</b>			
7.5.1	Gas and arc welding, rough spotwelding	200-300-500	3	
7.5.2	Medium soldering, brazing, spot welding	300-500-750	3	
7.5.3	Fine soldering, fine spotwelding	750-1000-1500	2	Local lighting is desirable
<b>7.6</b>	<b>Assembly Shops</b>			
7.6.1	Rough work, for example, frame and heavy machine assembly	200-300-500	3	The lighting of vertical surface may be important
7.6.2	Medium work, for example, office machinery assembly	300-500-750	2	
7.6.3	Fine work, for example, office machinery assembly	500-750-1000	1	Localized lighting may be useful
7.6.4	Very fine work, for example, instrument assembly	750-1000-1500	1	Local lighting and optical aids are desirable
7.6.5	Minute work for example, watchmaking	1000-1500-2000	1	Local lighting and optical aids are desirable
<b>7.7</b>	<b>Inspection and Testing Shops</b>			
7.7.1	Coarse Work, for example, using go/ on go gauge, inspection of large sub-assembly	300-500-750	2	Local or localized lighting may be appropriate
7.7.2	Medium work for example, inspection of painted surfaces	500-750-1000	1	Local or localized lighting may be appropriate
7.7.3	Fine work, for example, using calibrated scales, inspection of precision mechanism	750-1000-1500	1	Local or localized lighting may be appropriate
7.7.4	Very fine work, for example, inspection of small intricate parts	1000-1500-2000	1	Local lighting and optical aids are desirable
7.7.5	Minute work, for example, inspection of very small instruments	2000	1	Local lighting and optical aids are desirable
<b>7.8</b>	<b>Points shops and Spray Booths</b>			
7.8.1	Dipping, rough spraying	200-300-500	3	
7.8.2	Preparation, ordinary painting, spraying & finishing	200-500-750	2	
7.8.3	Fine painting, Spraying and finishing	500-750-1000	2	
7.8.4	Inspection, retouching and matching	750-1000-1500	2	
<b>7.9</b>	<b>Plating shops</b>			
7.9.1	Vats and baths	200-300-500	3	
7.9.2	Buffing, polishing, burnishing	300-500-750	2	

7.9.3	Final buffing and polishing	500-750-1000	2	
7.9.4	Inspection	-		Special light to reveal fault in the surface of the material be required
<b>8</b>	<b>ELECTRICAL AND ELECTRONIC ENGG</b>			
<b>8.1</b>	<b>Electrical Equipment manufacture</b>			
8.1.1	Manufacture of cables & insulated wires, winding, varnishing & immersion of coils, assembly of large machines, simple assembly work	200-300-500	3	
8.1.2	Medium assembly, forexample Telephones, small motors	300-500-750	3	Local lighting may be appropriate
8.1.3	Assembly of precision components, for eg. telecommunication equipment, adjustment, inspection and calibration	750-1000-1500	1	Local lighting is desirable. Optical aids may be useful.
8.1.4	Assembly of high precision parts	1000-1500-2000	1	Local lighting is desirable. Optical aids may be useful.
<b>8.2</b>	<b>Electronic Equipment Manufacture</b>			
<b>8.2.1</b>	<b>Printed Circuit Board</b>			
8.2.1.1	Silk Screening	300-500-750	1	Local lighting may be appropriate
8.2.1.2	Hand insertion of components, soldering	500-750-1000	1	Local lighting may be appropriate
8.2.1.3	Inspection	750-1000-1500	1	A large, low luminance luminaire overhead ensures specular reflection conditions which are helpful for inspection of printed circuit Local lighting may be appropriate.
8.2.1.4	Assembly of wiring harness, clearing harness, testing and calibration	500-750-1000	1	Local lighting may be appropriate
8.2.1.5	Chassis assembly	750-1000-1500	1	Local lighting may be appropriate
<b>8.2.2</b>	<b>Inspection and testing</b>			
8.2.2.1	Soak test	150-200-300	2	
8.2.2.2	Safety and functional tests	200-300-500	2	

<b>9</b>	<b>FOOD, DRINKS AND TOBACCO</b>			
<b>9.1</b>	<b>Slaughter houses</b>			
9.1.1	General	200-300-500	3	
9.1.2	Inspection	300-500-750	2	
<b>9.2</b>	<b>Canning, Preserving and Freezing</b>			
9.2.1	Grading and sorting of raw materials	500-750-1000	2	Lamps of colour rendering group 1A or 1B will be required, if colour judgement is required.
<b>9.2.2</b>	<b>Preparation</b>	300-500-750	3	
<b>9.2.3</b>	<b>Canned and bottled goods</b>			
9.2.3.1	Retorts	200-300-500	3	
9.2.3.2	Automatic processes	150-200-300	3	
9.2.3.3	Labeling and packaging	200-300-500	3	
<b>9.2.4</b>	<b>Frozen foods</b>			
9.2.4.1	Process area	200-300-500	3	
9.2.4.2	Packaging and storage	200-300-500	3	
<b>9.3</b>	<b>Bottling, Brewing &amp; Distilling</b>			
9.3.1	Keg washing and handling, bottle washing	150-200-300	3	
9.3.2	Keg inspection	200-300-500	3	
9.3.3	Bottle inspection		3	Special lighting will be required.
9.3.4	Process area	200-300-500	3	
9.3.5	Bottle filling	500-750-1000	3	
<b>9.4</b>	<b>Edible oils and Fats Processing</b>			
9.4.1	Refining and Blending	200-300-500	3	
9.4.2	Production	300-500-750	2	
9.5	Mills-milling, Filtering and Packing	200-300-500	3	
<b>9.6</b>	<b>Bakeries</b>			
9.6.1	General	200-300-500	2	
9.6.2	Hand decorating, icing	300-500-750	2	
<b>9.7</b>	<b>Chocolate and Confectionery Manufacturer</b>			
9.7.1	General	200-300-500	3	
9.7.2	Automatic processes	150-200-300	3	
9.7.3	Hand decoration, inspection, wrapping and packing	300-500-750	2	If accurate colour judgement is required, lamps of colour rendering group of 1A or 1B are used.
<b>9.8</b>	<b>Tobacco Processing</b>			
9.8.1	Material preparation, making	300-500-750	2	

	and packing			
<b>10</b>	<b>TEXTILES</b>			
<b>10.1</b>	Fiber preparation			
10.1.1	Bale breaking, washing	200-300-500	3	
10.1.2	Stock dyeing, tinting	200-300-500	3	
<b>10.2</b>	Yarn manufacturer			
10.2.1	Spinning, roving, winningest.	300-500-750	2	
10.2.2	Heading (drawing in)	750-1000-750	2	
<b>10.3</b>	Fabric Production			
10.3.1	Knitting	300-500-750	2	
<b>10.3.2</b>	Weaving			
10.3.2.1	Jute and hemp	200-300-500	2	
10.3.2.2	Heavy woolens	300-500-750	1	
10.3.2.3	Medium fine woolens, cottons	500-750-1000	1	
10.3.2.4	Fine worsteds, fine linens, synthetics	750-1000-1500	1	
10.3.2.5	Mending	1000-1500-2000	1	
10.3.2.6	Inspection	1000-1500-2000	1	
<b>10.4</b>	Fabric Finishing			
10.4.1	Dyeing	200-300-500	3	
10.4.2	Calendering, Chemical treatment, etc.	300-500-750	2	
<b>10.4.3</b>	Inspection			
10.4.3.1	Grey cloth	750-1000-1500	1	
10.4.3.2	Final	1000-1500-2000	1	
<b>10.5</b>	<b>Carpet Manufacturers</b>			
10.5.1	Winding, beaming	200-300-500	3	
10.5.2	Setting pattern, tufting cropping, Trimming, Fringing, latexing and latex drying	300-500-750	2	
10.5.3	Designing, weaving, mending	500-750-1000	2	
10.5.4	Inspection			
10.5.4.1	General	750-1000-1500	1	Local lighting may be appropriate
10.5.4.2	Piece dyeing	500-750-1000	1	Local lighting may be appropriate
<b>11</b>	<b>LEATHERINDUSTRY</b>			
<b>11.1</b>	<b>Leather Manufacturers</b>			
11.1.1	Cleaning, tanning and stretching, vats, cutting, fleshing, stuffing	200-300-500	3	
11.1.2	Finishing, scarfing	300-500-750	2	
<b>11.2</b>	<b>Leatherworking</b>			
11.2.1	General	200-300-500	3	
11.2.2	Pressing, glazing	300-500-750	2	
11.2.3	Cutting, splitting, scarfing, sewing	500-750-1000	2	Directional lighting may be useful

11.2.4	Grading, matching		2	Local lighting may be appropriate
<b>12</b>	<b>CLOTHING AND FOOTWEAR</b>			
<b>12.1</b>	<b>Clothing Manufacturers</b>			
12.1.1	Preparation of cloth	200-300-500	2	
12.1.2	Cutting	500-750-1000	1	
12.1.3	Matching	500-750-1000	1	
12.1.4	Sewing	750-1000-1500	1	
12.1.5	Pressing	300-500-750	2	
12.1.6	Inspection	1000-1500-2000	1	Local lighting may be appropriate
12.1.7	Hand tailoring	1000-1500-2000	1	Local lighting may be appropriate
<b>12.2</b>	<b>Hosiery and Knitwear Manufacturer</b>			
12.2.1	Flat bed knitting machines	300-500-750	2	
12.2.2	Circular knitting machines	500-750-1000	2	
12.2.3	Lock stitch and over locking machine	750-1000-1500	1	
12.2.4	Linking or running on	750-1000-1500	1	
12.2.5	Mending, hand finishing	1000-1500-3000	-	Local lighting may be appropriate
12.2.6	Inspection	1000-1500-2000	2	Local lighting may be appropriate
<b>12.3</b>	<b>Glove Manufacture</b>			
12.3.1	Sorting & grading	500-750-1000	1	
12.3.2	Pressing, knitting, cutting	300-500-750	2	
12.3.3	Sewing	500-750-1000	2	
12.3.4	Inspection	1000-1500-2000	-	Local lighting may be appropriate
<b>12.4</b>	<b>Hat Manufacturer</b>			
12.4.1	Stiffening, braiding, refining, forming, sizing, pounding, ironing	200-300-500	2	
12.4.2	Cleaning, flanging, finishing	300-500-750	2	
12.4.3	Sewing	500-750-1000	2	
12.4.4	Inspection	1000-1500-2000	-	Local lighting may be appropriate
<b>12.5</b>	<b>Boot and Shoe Manufacturer</b>			
12.5.1	Leather and Synthetics			
12.5.2	Sorting and Grading	750-1000-1500	1	
12.5.3	Clicking closing	750-1000-1500	2	Local or localized lighting may be appropriate
12.5.4	Preparatory Operations	750-1000-1500	2	Local or localized lighting may be appropriate
12.5.5	Cutting tables and pressure	1000-1500-2000	1	Local or localized lighting may

				be appropriate
12.5.6	Bottom stock preparation, lasting, Bottoming finishing, showrooms	750-1000-1500	1	Local or localized lighting may be appropriate
<b>12.5.7</b>	<b>Rubber</b>			
12.5.7.1	Washing, compounding, coating, drying, varnishing, vulcanizing	200-300-500	3	
12.5.7.2	Lining, making and finishing	300-500-750	2	
<b>13</b>	<b>TIMBER AND FURNITURE</b>			
<b>13.1</b>	<b>Sawmills</b>			
13.1.1	General	150-200-300	3	
13.1.2	Head saw	300-500-750	2	Localized lighting may be appropriate
13.1.3	Grading	500-750-1000	2	Directional lighting may be useful
<b>13.2</b>	<b>Wood Workshops</b>			
13.2.1	Rough sawing, benchwork	200-300-500	2	
13.2.2	Sizing, planning, sanding, medium machining and benchwork	300-500-750	2	
13.2.3	Fine bench & machine work, fine sanding, finishing	500-750-1000	2	Localized lighting may be appropriate
<b>13.3</b>	<b>Furniture manufacture</b>			
13.3.1	Raw material stores	50-100-150	3	
13.3.2	Finished goods stores	100-150-200	3	
13.3.3	Wood matching and assembly, rough sawing, cutting	200-300-500	2	
13.3.4	Machining, sanding and assembly, polishing	300-500-750	2	Localized lighting may be appropriate
13.3.5	Toolrooms	300-500-750	2	
<b>13.3.6</b>	<b>Spray booths</b>			
13.3.6.1	Colour finishing	300-500-750	2	
13.3.6.2	Clear finishing	200-300-500	2	
<b>13.3.7</b>	<b>Cabinetmaking</b>			
13.3.7.1	Vaneer sorting and grading	750-1000-1500	1	
13.3.7.2	Marquetry, pressing, patching and fitting	300-500-750	1	
13.3.7.3	Final inspection	500-750-1000	1	Special lighting will be required
<b>13.4</b>	<b>Upholstery Manufacturer</b>			
13.4.1	Cloth inspection	1000-1500-2000	1	Special lighting will be required
13.4.2	Filling, covering	300-500-750	2	
13.4.3	Slipping, cutting, sewing	500-750-1000	2	
13.4.4	Mattress making			
13.4.5	Assembly	300-500-750	2	

13.4.6	Tape edging	750-1000-1500	2	Local lighting may be appropriate
<b>14</b>	<b>PAPER AND PRINTING</b>			
<b>14.1</b>	<b>Paper Mills</b>			
14.1.1	Pulp mills, preparation plants	200-300-500	3	
<b>14.1.2</b>	<b>Paper and board making</b>			
14.1.2.1	General	200-300-500	3	
14.1.2.2	Automatic process	150-200-300	3	Supplementary lighting may be necessary for maintenance work
14.1.2.3	Inspection, sorting	300-500-750	1	
<b>14.1.3</b>	<b>Paper converting process</b>			
14.1.3.1	General	200-300-500	3	
14.1.3.2	Associated printed	300-500-750	2	
<b>14.2</b>	<b>Printed works</b>			
<b>14.2.1</b>	<b>Type foundries</b>			
14.2.1.1	Matrix making, dressing type, hand and machine coating	200-300-500	3	
14.2.1.2	Front assembly, sorting	500-750-1000	2	
<b>14.2.2</b>	<b>Composing room</b>			
14.2.2.1	Hand composing, imposition and distribution	500-750-1000	1	
14.2.2.2	Hot metal keyboard	500-750-1000	1	
14.2.2.3	Hot metal casting	200-300-500	2	
14.2.2.4	Photo composing keyboard or setters	300-500-750	1	
14.2.2.5	Pasteup	500-750-1000	1	
14.2.2.6	Illuminated tables-general lighting	200-300-500		Dimming may be required
14.2.2.7	Proof process	300-500-750	2	
14.2.2.8	Proof reading	500-750-1000	1	
<b>14.2.3</b>	<b>Graphic reproduction</b>			
14.2.3.1	General	300-500-750	2	
14.2.3.2	Precision proofing, retouching, etching	750-1000-1500	1	Local lighting may be appropriate
14.2.3.3	Colour	750-1000-1500	1	
<b>14.2.4</b>	<b>Printing Machine Room</b>			
14.2.4.1	Presses	300-500-750	2	
14.2.4.2	Pre-make ready	300-500-750	2	
14.2.4.3	Printed sheet inspection	750-1000-1500	1	
<b>14.2.5</b>	<b>Binding</b>			
14.2.5.1	Folding, pasting, punching and stitching	300-500-750	2	
14.2.5.2	Cutting, assembling, embossing	500-750-1000	2	

<b>15</b>	<b>PLASTIC AND RUBBER</b>			
<b>15.1</b>	<b>Plastic Product</b>			
<b>15.1.1</b>	<b>Automatic plant</b>			
15.1.1.1	Without manual control	30-50-100	3	
15.1.1.2	With occasional manual control	50-100-150	3	
15.1.1.3	With continuous manual control	200-300-500	3	
15.1.1.4	Control rooms	200-300-500	1	
15.1.1.5	Control platforms	200-300-500	2	Local lighting may be appropriate
<b>15.1.2</b>	<b>Non-automatic plant</b>			
15.1.2.1	Mixing, calendaring, extrusion, injection, compression and blow moulding, sheet fabrication	200-300-500	3	
15.1.2.2	Trimming, cutting, polishing	300-500-750	2	
15.1.2.3	Printing, inspection	750-1000-1500	1	
<b>15.2</b>	<b>Rubber products</b>			
15.2.1	Stock preparation - plastisizing, milling	150-200-300	3	
15.2.2	Calendaring, fabric preparation, stock- cutting	300-500-750	3	
15.2.3	Extruding, moulding	300-500-750	2	
15.2.4	Inspection	750-1000-1500	-	
<b>16</b>	<b>DISTRIBUTION AND STORAGE</b>			
<b>16.1</b>	<b>Work stores</b>	100-150-200	3	Avoid glare to drivers of vehicles approaching the loading bay
16.1.1	Unpacking, sorting	150-200-300	3	Avoid glare to drivers of vehicles approaching the loading bay
16.1.2	Large item storage	50-100-150	3	Avoid glare to drivers of vehicles approaching the loading bay
16.1.3	Small item rack storage	200-300-500	3	Avoid glare to drivers of vehicles approaching the loading bay
16.1.4	Issue counter, records, storminess	300-500-750	3	Avoid glare to drivers of vehicles approaching the loading bay
<b>16.2</b>	<b>Warehouses and bulk stores</b>			
16.2.1	Storage of goods where identification requires only limited preparation of details	50-100-150	3	
16.2.2	Storage of goods where	100-150-200	3	

	identification requires perception of detail			
<b>16.2.3</b>	<b>Automatic high bay rack stores</b>			
16.2.3.1	Gangway	20		
16.2.3.2	Control station	150-200-300	3	
16.2.3.3	Packing and dispatch	200-300-500	3	
16.2.3.4	Loading bays	100-150-200	3	Avoid glare to drivers of vehicles approaching the loading bay
<b>16.3</b>	<b>Cold stores</b>			
16.3.1	General	200-300-500	3	
16.3.2	Breakdown, make-up and dispatch	200-300-500	3	
16.3.3	Loading bays	100-150-200	3	Avoid glare to drivers of vehicles approaching the loading bay
<b>17</b>	<b>COMMERCE</b>			
<b>17.1</b>	<b>Offices</b>			
17.1.1	General offices	300-500-750	1	
17.1.2	Deep plan General offices	500-750-1000	1	
17.1.3	Computer workstation	300-500-750	1	
17.1.4	Conference Rooms, Executive offices	300-500-750	1	
17.1.5	Computer and data preparation Rooms	300-500-750	1	
17.1.6	Filing rooms	200-300-500	1	
<b>17.2</b>	<b>Drawing Office</b>			
17.2.1	General	300-500-750	1	
17.2.2	Drawing Board	500-750-1000	1	
17.2.3	Computer aided design and drafting			Special lighting is required
17.2.4	Print rooms	200-300-500	1	
<b>17.3</b>	<b>Banks and building societies</b>			
17.3.1	Counter, office area	300-500-750	1	
17.3.2	Public area	200-300-500	1	
<b>18</b>	<b>SERVICES</b>			
<b>18.1</b>	<b>Garages</b>			
18.1.1	Interior parking areas	20-30-50	3	
18.1.2	General repairs, servicing, washing, polishing	200-300-500	2	
18.1.3	Workbench	300-500-750	1	Local or localized lighting may be appropriate
18.1.4	Spray Booths	300-500-750	1	
<b>18.1.5</b>	<b>External apron</b>			
18.1.5.1	General	30-50-100		Care should be taken to avoid glare to drivers and

				neighbouring residents <i>see</i> 'Retailing'
18.1.5.2	Pump area (retail details)	200-300-500		
<b>18.2</b>	<b>Appliance servicing</b>			
<b>18.2.1</b>	<b>Workshop</b>			
18.2.1.1	General	200-300-500	2	
18.2.1.2	Workbench	300-500-750	2	Localized lighting may be appropriate
18.2.1.3	Counter	200-300-500	2	Localized lighting may be appropriate
18.2.1.4	Stores	200-300-500	3	
<b>18.3</b>	<b>Laundries</b>			
<b>18.3.1</b>	Commercial laundries			
18.3.2	Receiving, sorting, washing, drying, ironing, dispatch, dry-cleaning, bulk machine work	200-300-500	3	
18.3.3	Head ironing, pressing, mending, spotting, inspection	300-500-750	3	
18.3.4	Launderettes	200-300-500	3	
<b>18.4</b>	<b>Sewage Treatment Works</b>			
18.4.1	Walkways	30-50-100	3	
18.4.2	Process areas	50-100-150	3	
<b>19</b>	<b>RETAILING</b>			
19.1	Small Shops with Counters	300-500-750	1	
19.2	Small Self Service shops with island displays	300-500-750	1	
<b>19.3</b>	<b>Super Markets, Hyper-Markets</b>			
19.3.1	General	300-500-750	2	
19.3.2	Checkout	300-500-750	2	
19.3.2	Showroom for large objects, for e.g. cars, furniture	300-500-750	1	
19.3.4	Shopping precincts and arcades	100-150-200	2	
<b>20</b>	<b>PLACES OF PUBLICASSEMBLY</b>			
20.1	Public rooms, Village halls, Worship halls	200-300-500	1	
<b>20.2</b>	<b>Concert Halls, Cinemas and theaters</b>			
20.2.1	Foyer	150-200-300		
20.2.2	Booking Office	200-300-500		
20.2.3	Auditorium	50-100-150		
20.2.4	Dressing Room	200-300-500		
20.2.5	Projection Rooms	100-150-200		
<b>20.3</b>	<b>Churches</b>			
20.3.1	Body of church	100-150-200	2	
20.3.2	Pulpit, Lectern	200-300-500	2	

20.3.3	Choir Stalls	200-300-500	2	
20.3.4	Alter, communion table, cancel	100-150-200	2	
20.3.5	Vestries	100-150-200	2	
20.3.6	Organ	200-300-500		
<b>20.4</b>	<b>Hospitals</b>			
<b>20.4.1</b>	<b>aesthetic Rooms</b>			
20.4.1.1	General	200-300-500		
20.4.1.2	Local	750-1000-1500		
<b>20.4.2</b>	<b>Consulting Area</b>			
20.4.2.1	General	200-300-500		
20.4.2.2	Examination	750-1000-1500		
<b>20.4.3</b>	<b>Corridors</b>			
20.4.3.1	General	100-150-200		
<b>20.4.4</b>	<b>Ward corridors</b>			
20.4.4.1	Cubicles	100-150-300		
20.4.4.2	General	100-150-300 (total)		
20.4.4.3	Treatment	100-150-200		
20.4.4.4	Examination	5-10		
<b>20.4.5</b>	<b>General</b>			
20.4.5.1	Local inspection	200-300-500		
20.4.5.2	Intensive therapy	750-1000-1500		
<b>20.4.6</b>	<b>Bedhead</b>			
20.4.6.1	Circulation between bed ends	200-300-500		
20.4.6.2	Observation	750-1000-1500		
<b>20.4.7</b>	<b>Local observation</b>			
20.4.7.1	Staff base(day)	30-50		
20.4.7.2	Staff base(night)	50-100-150		
20.4.7.3	Cubicles	200-300-500		
20.4.7.4	General	750-1000-1500		
20.4.7.5	Treatment	200-300-500		
20.4.7.6	Examination	30		
<b>20.4.8</b>	<b>Laboratories</b>			
20.4.8.1	General	200-300-500		
20.4.8.2	Examination	300-500-750		
<b>20.4.9</b>	<b>Nurses station</b>			
20.4.9.1	Morning/day/evening	200-300-500		
20.4.9.2	Night desks	30		
20.4.9.3	Night, medical trolleys	50-100-150		
<b>20.4.10</b>	<b>Operating theatres</b>			
20.4.10.1	General	300-500-750		
20.4.10.2	Local	10000 to 50000		Special operating lights are used
<b>20.4.11</b>	<b>Pathology Department</b>			
20.4.11.1	General	200-300-500		
20.4.11.2	Examination	300-500-750		
20.4.11.3	Pharmacies	200-300-500		

20.4.11.4	Reception/inquiry	200-300-500		
20.4.11.5	Recovery rooms	200-300-500		
<b>20.4.12</b>	<b>Ward circulation</b>			
<b>20.4.12.1</b>	Day	50-100-150		
20.4.12.1	Morning/evening	50-100-150		
20.4.12.2	Night	3-5		
<b>20.4.13</b>	<b>Ward bedhead</b>			
20.4.13.1	Morning/Evening	30-50		
20.4.13.2	Reading Night	100-150-200		
<b>20.4.14</b>	<b>Night</b>			
20.4.14.1	Adult	0.1-1		
20.4.14.2	Pediatric	1		
20.4.14.3	Psychiatric	1-5		
20.4.14.4	Watch	5		
<b>20.4.15</b>	<b>X-ray Areas</b>			
20.4.15.1	General	150-200-300		
20.4.15.2	Diagnostic	150-200-300		
20.4.15.3	Operative	200-300-500		
20.4.15.4	Process dark	50		
<b>20.4.16</b>	<b>Surgeries</b>			
20.4.16.1	General	200-300-500		
20.4.16.2	Waiting rooms	100-150-200		
<b>20.4.17</b>	<b>Dental Surgeries</b>			
20.4.17.1	Chair	Special lighting		
20.4.17.2	Laboratories	300-500-750		
<b>20.4.18</b>	<b>Consulting rooms</b>			
20.4.18.1	General	200-300-500		
20.4.18.2	Desk	300-500-750		
20.4.18.3	Examination	300-500-750		
20.4.18.4	Ophthalmic wall & near-vision charts	300-500-750		
<b>20.5</b>	<b>Hotels</b>			
20.5.1	Entrance Halls	50-100-150		
20.5.2	Reception, cashiers and porters Desks	200-300-500		Localized lighting may be appropriate
20.5.3	Bars, coffee base, dinning rooms, grill, rooms, restaurants, lounges	50-200		The lighting should be designed to create an appropriate atmosphere
20.5.4	Cloak room, baggage rooms	50-100-150	3	
20.5.5	Bed rooms	30-50-100		Supplementary local lighting at the bed head, writing table should be provided
20.5.6	Bathroom	50-100-150		Supplementary local lighting near the mirror is desirable
20.5.7	Food preparation and stores, cellars, lifts and corridors			See 'General Building Areas'

<b>20.6</b>	<b>Libraries</b>			
<b>20.6.1</b>	<b>Lending libraries</b>			
20.6.1.1	General	200-300-500	1	
20.6.1.2	Counters	300-500-750	1	Localized lighting may be appropriate
20.6.1.3	Bookshelves	100-150-200	2	The service illuminance should be provided on the vertical surface at the bottom of the book shelves
20.6.1.4	Reading rooms	200-300-500	1	
20.6.1.5	Reading tables	200-300-500	1	Localized lighting may be appropriate
<b>20.6.2</b>	<b>Catalogues</b>			
20.6.2.1	Card	100-150-200	2	
20.6.2.2	Microfiche/visual display units	100-150-200	2	
<b>20.6.3</b>	<b>Reference libraries</b>			
20.6.3.1	General	200-300-500	1	
20.6.3.2	Counters	300-500-750	1	Localized lighting may be appropriate
20.6.3.3	Bookshelves	100-150-200	2	The service illuminance should be provided on the vertical surface at the bottom of the book shelves
20.6.3.4	Study tables, carrels	300-500-750	1	
20.6.3.5	Map room	200-300-500	1	
<b>20.6.4</b>	<b>Display and exhibition areas</b>			
20.6.4.1	Exhibits insensitive to light	200-300-500		
20.6.4.2	Exhibit sensitive to light, for example, pictures, prints, rare books in archives	50 to 150		
<b>20.6.5</b>	<b>Library workrooms</b>			
20.6.5.1	Book repair and binding	300-500-750		
20.6.5.2	Catalogue and sorting	300-500-750		
20.6.5.3	Remote book stores	100-150-200		
<b>20.7</b>	<b>Museums and art galleries</b>			
20.7.1	Exhibits insensitive to light	200-300-500		
20.7.2	Light sensitive exhibits, for example, oil and temper paints, undyed leather, bone, ivory, wood, etc	150		This is a maximum illuminance to be provided on the principal plane of the exhibit
20.7.3	Extremely light sensitive exhibits, for e.g. textiles, water colours, prints and drawing, skins, botanical specimens, etc.	50		This is a maximum illuminance to be provided on the principal plane of the object
20.7.4	Conservation studies and workshops	300-500-750		
20.8	Sports Facilities	300-750		This lighting system should be

	Multi-purpose sports hall			sufficiently flexible to provide lighting suitable for the variety of sports and activities that take place in sports halls. Higher illuminance of 1000-2000 lux would be required for television coverage.
<b>21</b>	<b>EDUCATION</b>			
<b>21.1</b>	<b>Assembly Halls</b>			
21.1.1	General	200-300-500	3	
<b>21.1.2</b>	Platform and stage			Special lighting to provide emphasis and to facilitate the use of the platform/stage is desirable
<b>21.2</b>	<b>Teaching Spaces</b>			
21.2.1	General	200-300-500	1	
<b>21.3</b>	<b>Lecture Theatres</b>			
21.3.1	General	200-300-500	1	
21.3.2	Demonstration benches	300-500-750	1	Localized lighting may be appropriate
21.4	Seminar Rooms	300-500-750	1	
21.5	Art Rooms	300-500-750	1	
21.6	Needlework Rooms	300-500-750	1	
21.7	Laboratories	300-500-750	1	
21.8	Libraries	200-300-500	1	
21.9	Music rooms	200-300-500	1	
21.10	Sport halls	200-300-500	1	
21.11	Workshops	200-300-500	1	
<b>22</b>	<b>TRANSPORT</b>			
<b>22.1</b>	<b>Airports</b>			
22.1.1	Ticket counters, checking, desks and information desks	300-500-750	2	Localized lighting may be appropriate
22.1.2	Departure lounges, other waiting areas	150-200-300	2	
22.1.3	Baggage reclaim	150-200-300	2	
22.1.4	Baggage handling	50-100-150	2	
22.1.5	Customers and immigration halls	300-500-750	2	
<b>22.1.6</b>	Concourse	150-200-300	2	
<b>22.2</b>	<b>Railway Stations</b>			
22.2.1	Ticket office	300-500-750	2	Localized lighting may be appropriate
22.2.2	Information Office	300-500-750	2	Localized lighting over the counter may be appropriate
22.2.3	Parcels office, left			
<b>22.2.4</b>	<b>Luggage Office</b>			
22.2.4.1	General	50-100-150	2	

22.2.4.2	Counter	150-200-300	2	
22.2.5	Waiting rooms	150-200-300	2	
22.2.6	Concourse	150-200-300	2	
22.2.7	Time table	150-200-300	2	Localized lighting may be appropriate
22.2.8	Ticket barriers	150-200-300	2	Localized lighting may be appropriate
22.2.9	Platforms (covered)	30-50-100	2	Care should be taken to light and mark the edge of the platform clearly
22.2.10	Platforms (open)	20		Care should be taken to light and mark the edge of the platform clearly
<b>22.3</b>	<b>Coach stations</b>			
22.3.1	Tickets offices	300-500-750	2	Localized lighting over the counter may be appropriate
22.3.2	Information offices	300-500-750	2	Localized lighting over the counter may be appropriate
<b>22.3.3</b>	<b>Left luggage office</b>			
22.3.3.1	General	50-100-150	3	
22.3.3.2	Counter	150-200-300	3	Localized lighting is appropriate
22.3.4	Waiting rooms	150-200-300	2	
22.3.5	Concourse	150-200-300	2	
22.3.6	Time Tables	150-200-300	2	Localized lighting is appropriate
22.3.7	Loading areas	100-150-200	3	
<b>23</b>	<b>General Building Areas</b>			
<b>23.1</b>	<b>Entrance</b>			
23.1.1	Entrance halls, lobbies, waiting rooms	150-200-300	2	
23.1.2	Enquiry desks	300-500-750	2	Localized lighting is appropriate
23.1.3	Gatehouses	150-200-300	2	
<b>23.2</b>	<b>Circulation areas</b>			
23.2.1	Lifts	50-100-150		
23.2.2	Corridors, passageways, stairs	50-100-150	2	
23.2.3	Escalators, revelators	100-150-200		
<b>23.3</b>	<b>Medical and first aid centres</b>			
23.3.1	Consulting rooms, treatment rooms	300-500-750	1	
23.3.2	Rest rooms	100-150-200	1	
23.3.3	Medical stores	100-150-200	2	
<b>23.4</b>	<b>Staff rooms</b>			
23.4.1	Changing, locker and cleaners rooms, cloakrooms, lavatories	50-100-150		

23.4.2	Restrooms	100-150-200	1	
<b>23.5</b>	<b>Staff restaurants</b>			
23.5.1	Canteens, cafeterias, dining rooms, mess rooms	150-200-300	2	
23.5.2	Survery, vegetable preparation, washing-up area	200-300-500	2	
23.5.3	Food preparation and cooking	300-500-750	2	
23.5.4	Food stores, cellars	100-150-200	2	
<b>23.6</b>	<b>Communications</b>			
23.6.1	Switchboard rooms	200-300-500	2	
23.6.2	Telephone apparatus rooms	100-150-200	2	
23.6.3	Telex room, post room	300-500-750	2	
23.6.4	Reprographic room	200-300-500	2	
<b>23.7</b>	<b>Building services</b>			
<b>23.7.1</b>	<b>Boiler houses</b>			
23.7.1.1	General	50-100-150	3	
23.7.1.2	Boiler front	100-150-200	3	
23.7.1.3	Boiler control room	200-300-500	2	Localized lighting of the control display and the control desk may be appropriate
23.7.1.4	Control rooms	200-300-500	2	Localized lighting of the control display and the control desk may be appropriate
23.7.1.5	Mechanical plant room	100-150-200	2	
23.7.1.6	Electrical power supply and distribution rooms	100-150-200	2	
23.7.1.7	Store rooms	50-100-150	3	
<b>23.8</b>	<b>Car parks</b>			
<b>23.8.1</b>	<b>Covered car parks</b>			
23.8.1.1	Floors	5-20		
23.8.1.2	Ramps and corners	30		
23.8.1.3	Entrances and exits	50-100-150		
23.8.1.4	Control booths	150-200-300		
23.8.1.5	Outdoor car parks	5-20		

**Note:** For details on use of the range of illumination given in three steps in this table, reference shall be made to 4.1.4.2, 4.1.4.2.1 and 4.1.4.2.2 for details on quality class of direct glare limitation, reference shall be made to 4.1.3.1.

**TABLE 9**  
**EXPECTED USEFUL LIFE OF VARIOUS ELECTRICAL EQUIPMENT/  
INSTALLATIONS ETC.**

Sl. No	Description of Equipment/ Installation	Life in Years
(1)	(2)	(3)
<b>A.</b>	<b>Wiring of Electrical Installations</b>	
1	Conduit wiring non-coastal area	20
2	Conduit wiring coastal area	15
3	Casing and capping wiring	Deleted
4	PVC wiring on batten	Deleted
5	L.S. wiring	Deleted
6	T.R.S. wiring	Deleted
7	Cleat Wiring	Deleted
8	MS Pole	20
9	GI Pole	25
<b>B.</b>	<b>Fans</b>	
1	Ceiling Fan AC	15
2	Ceiling Fan DC	Deleted
3	Exhaust Fan AC/DC DC	6 DC may be deleted
4	Table Fan AC/DC	Deleted
5	Pedestal/ Air circulated Fan	Deleted
<b>C.</b>	<b>External Electrical Lines</b>	
1	Temporary overhead lines on wooden poles	Deleted
2	Permanent overhead line on steel/ RCC poles	20
3	Underground Cable Lines	20
<b>D.</b>	<b>Sub-station Equipment</b>	
1	Switchgear LT/HT	20
2	Transformers	25
3	Servo voltage stabilizer	10
<b>E.</b>	<b>Lifts</b>	
1	Electric Lifts	15-20

2	Escalators	15-20
3	Hospital Lifts	10-15
	<b>Note:</b> “Now a days the technology up gradation of lifts including other E&M equipment is changing fast. So depending upon circumstances of technology up gradation resulting in substantial saving in electricity cost, life of the lift including other E&M equipment can be reduced with prior approval of the Chief Engineer.” <b>[No. DG/Amendment(E&amp;M)/2016/01, Part-1 Internal-Amendment no. 1/2016 dated 02-08-2016]</b>	
<b>F.</b>	<b>Electric Motors and Pumps</b>	
1	Electric Motors single phase	Deleted
2	Electric Motors three phase	15
3	Electric pumps small (3000 RPM) AC/ DC	Deleted
4	Electric pumps medium (11500 RPM) AC/ DC	Deleted
5	(Diesel) Engine pump upto 10 H.P.	10
6	Storm water pump	7
7	Water supply Pump (Centrifugal)	10
8	Sewage Pump	5
9	(Diesel) Engine pump above 10 H.P.	12
10	Diesel Generator upto 50 KW	12
11	Diesel Generator above 50 KW	15 Above 15 KW may be deleted
<b>G.</b>	<b>Refrigerators, Coolers &amp; Air Conditioners</b>	
1	Refrigerators	6
2	Cold storage plant with air-cooled condensing unit	8
3	Cold storage plant with water cooled condensing unit	Deleted
4	Desert Coolers [1500-2000 cfm (Evaporative type)]	4
5	Water Coolers	5
6	Room coolers cheap type about 1000 cfm	Deleted
7	Window type/ Split type/ Air-conditioning/ units with air cooled condensers	7
8	Packaged type Air-conditioning units with water cooled condensers	10
9	Packaged type Air-conditioning units with air cooled condensers	8
10	DX type central air-conditioned plant with water cooled condensers	Deleted
11	Central chilled water system of air-conditioning plant with water cooled condensers	20
12	Evaporative type air-cooling plant (upto 25,000 cfm.)	10
13	Evaporative type air-cooling plant above 25,000 cfm.	Deleted

<b>H.</b>	<b>Mechanical Machinery</b>	
<b>(a)</b>	<b><i>Asphalt Plant</i></b>	
1	Hotmix Asphalt Plant (upto 10 TPH)	Deleted
2	Hotmix Asphalt Plant (10 to 30 TPH)	Deleted
3	Hotmix Asphalt Plant (30/45 TPH)	Deleted
4	Tar/Bitumen heater 1000 - 1500 litres capacity	Deleted
5	Cold Asphalt mixer 30 cft.	Deleted
6	Asphalt power finishers	Deleted
<b>(b)</b>	<b><i>Compaction Equipment</i></b>	
1	Hand Roller 1/2 tonne	Deleted
2	Diesel Steel Wheel roller 8/10 tonne capacity	Deleted
3	Vibratory tandem roller 4 tonne	Deleted
4	Sheep's foot roller single/ double drum.	Deleted
<b>(c)</b>	<b><i>Concrete Plants</i></b>	
1	Concrete Mixer 3/5 cft. Capacity	Deleted
2	Concrete Mixer 0.28/0.20 and 0.39/0.28 cu.m. capacity	Deleted
3	Electric vibrator capacity 5 HP	Deleted
4	Vibrator Engine Driver , Immersion/ Screed board type above 2 HP - 5 HP	Deleted
<b>(d)</b>	<b><i>Earth Moving Machinery</i></b>	
1	Dozer	Deleted
2	Earth Rammer	Deleted
3	Front and Boarder 75 B.H.P.	Deleted
4	Front end loader 45 B.H.P.	Deleted
5	Motor Grader 60-80 BHP	Deleted
6	Electric driven portable Swivel Loader	Deleted
<b>(e)</b>	<b><i>Miscellaneous</i></b>	
1	Air-compressors 108-210 cf m	Deleted
2	Mobile Crane 4 tonne capacity	Deleted
3	Grass Cutter 1.52-1.8 3 m (5'-6'') cut mid/rear mounted	Deleted
4	Centrifugal pump upto 10 HP	Deleted

5	Trailer mounted Centrifugal Pump, Engine driven about 10 HP-50 HP	Deleted
6	Spray painting equipment complete	Deleted
7	Welding Transformers	Deleted
8	Pneumatic Rock Drill	Deleted
9	Pneumatic Pavement Breakers	Deleted
10	Generating set upto 50 KW with trolley	Deleted
11	Insulating Oil Dehydration plant upto 500 lit.	Deleted
12	Core Cutting machine	Deleted
13	Water Tank 910 lit. capacity trolley mounted	Deleted
14	Boilers	15
15	Incinerator	15
<b>(f)</b>	<b><i>Transport</i></b>	
1	Tipper/Truck	Deleted
2	Tractor 25-40 HP	Deleted
3	Tractor above 60-80 BHP	Deleted
4	Motor Car	5
5	Four wheeled trailer	Deleted
<b>(g)</b>	<b><i>Fire Fighting Equipment</i></b>	
1	Fire Alarm System	15
2	Water based wet riser/ sprinkler system	20

**Note :** These are general guidelines. Proposal for replacement will be based on actual hours of operation / conditions of use and inspection by the concerned authority. Based on adverse working condition, it may be necessary to replace installations earlier. Similarly replacement can be postponed if the existing condition is found to be satisfactory based on detailed inspection done. But it is necessary to keep close watch, when useful life is going to be over.

**TABLE 10****LIST OF T&P TO BE HELD BY EACH JUNIOR ENGINEER AS A MAINTENANCE UNIT**

1.	Earth Tester
2.	Insulation Tester LT/HT
3.	Tong Tester
4.	Multi meter
5.	Lux Meter
6.	Vernier Caliper
7.	Wire Gauge
8.	Hand Blower / Vacuum Cleaner
9.	Drill Machine
10.	Chase Cutting Machine
11.	Crimping toolkit
12.	Self-supporting ladder - 4 ft. 3Nos.
13.	Ladder - 20 ft. 1No.
14.	Electrical wiring drawing machine
15.	Cable fault locator machine
16.	One set of hydraulic crimping toolkit
17.	Earth Fault Loop impedance tester / Multi Tester
18.	Installation Tester (Voltage, current, loop impedance, RCD Tripping, insulation etc.)
<b>Note:</b> Item No. 15 & 16 will be procured based on the requirement.	

**TABLE 11-A**  
**Values of Performance Characteristics of 2 Pole Line Operated a.c. Motors**

*(Clauses 1.2, 1.3, 1.6, 10.1, 10.2, 11, 14.1, 14.4, 15.4.1, 17.3.5)*

S.No.	Rated Frame size Output		Full Load Speed	Full Load Current	Locked Torque in Terms of Full Load Torque	Locked Rotor Current in Terms of Full Load Current			Nominal Efficiency		
						IE2	IE3	IE4	IE2	IE3	IE4
	kW		Max Rev/min	A	Percent	Percent	Percent	Percent	Percent	Percent	
(1)	(2)	(3)	(4)	(5)	(6)	(7)	(8)	(9)	(10)	(11)	(12)
(i)	0.12	56	2 750	0.65	170	600	650	730	53.6	60.8	66.5
(ii)	0.18	63	2 750	0.84	170	600	650	730	60.4	65.9	70.8
(iii)	0.25	63	2 750	1.0	170	600	650	730	64.8	69.7	74.3
(iv)	0.37	71	2 750	1.2	170	650	700	780	69.5	73.8	78.1
(v)	0.55	71	2 760	1.6	170	650	700	780	74.1	77.8	81.5
(vi)	0.75	80	2 780	2.0	170	650	700	780	77.4	80.7	83.5
(vii)	1.1	80	2 790	2.8	170	650	700	780	79.6	82.7	85.2
(viii)	1.5	90S	2 800	3.7	170	650	700	780	81.3	84.2	86.5
(ix)	2.2	90L	2 810	5.0	170	700	770	890	83.2	85.9	88.0
(x)	3.7	100L	2 820	8.0	160	700	770	890	85.5	87.8	89.7
(xi)	5.5	132S	2 830	11.0	160	700	770	890	87.0	89.2	90.9
(xii)	7.5	132S	2 840	15.0	160	700	770	890	88.1	90.1	91.7
(xiii)	11.0	160M	2 860	21.5	160	700	770	890	89.4	91.2	92.6
(xiv)	15.0	160M	2 870	29.0	160	700	770	890	90.3	91.9	93.3
(xv)	18.5	160L	2 880	35.0	160	700	770	890	90.9	92.4	93.7
(xvi)	22.0	180M	2 890	41.5	160	700	770	890	91.3	92.7	94.0
(xvii)	30.0	200L	2 900	55.0	160	700	770	890	92.0	93.3	94.5
(xviii)	37.0	200L	2 900	67.0	160	700	770	890	92.5	93.7	94.8
(xix)	45.0	225M	2 955	80.0	160	700	770	890	92.9	94.0	95.0
(xx)	55.0	250M	2 960	95.0	160	700	770	890	93.2	94.3	95.3
(xxi)	75.0	280S	2 970	130.0	160	700	770	890	93.8	94.7	95.6
(xxii)	90.0	280M	2 970	150.0	160	700	770	890	94.1	95.0	95.8
(xxiii)	110.0	315S	2 980	185.0	160	700	770	890	94.3	95.2	96.0
(xxiv)	132.0	315M <sup>1)</sup>	2 980	220.0	160	700	770	890	94.6	95.4	96.2
(xxv)	160.0	315L <sup>1)</sup>	2 980	265.0	160	700	770	890	94.8	95.6	96.3
(xxvi)	200.0	As per	2 980	340.0	160	700	770	890	95.0	95.8	96.5

(xxvii)	250.0	manufac turer catalogu e	2 980	425.0	160	700	770	890	95.0	95.8	96.5
(xxviii)	315.0		2 980	536.0	160	700	770	890	95.0	95.8	96.5
(xxix)	355.0		2 980	604.0	160	700	770	890	95.0	95.8	96.5
(xxx)	375.0		2980	640	160	700	770	890	95.0	95.8	96.5
(xxxii)	450.0	As per manuf acture r catalo gue.	2980	As per manufactu rer catalogue.		700	770	890	95.0	95.8	96.5
(xxxiii)	500.0		2980			700	770	890	95.0	95.8	96.5
(xxxiv)	560.0		2980			700	770	890	95.0	95.8	96.5
(xxxv)	630.0		2980			700	770	890	95.0	95.8	96.5
(xxxvi)	710.0		2980			700	770	890	95.0	95.8	96.5
(xxxvii)	800.0		2980			700	770	890	95.0	95.8	96.5
(xxxviii)	900.0		2980			700	770	890	95.0	95.8	96.5
(xxxix)	1000.0		2980			700	770	890	95.0	95.8	96.5

## NOTES

1. Output to frame size relation is maintained in accordance with IS 1231 for all motors except those marked as<sup>1)</sup>, wherein the frame size indicated is 'preferred size'.
2. If the pull-up torque occurs at 0 speed, then minimum value of the starting torque permitted (subject to no tolerance) shall be 0.5 times the rated torque.
3. Sometimes motors are required to be offered in frame sizes higher than as stipulated in Table 3 of IS 1231. Such cases are covered for IE classification and marking. The motor shall meet the performance parameters of the rated power (Table 1 to Table 4).
4. Speeds declared above are indicative and actual values may be obtained from manufacturers' catalogue.
5. For intermediate power ratings, the performance characteristics (excluding efficiency) shall be as per the nearest standard rating. The maximum rated current will be declared by the manufacturer.

**TABLE 11-B**

**Values of Performance Characteristics of 4 Pole Line Operated a.c. Motors**

(Clauses 1.2, 1.3, 1.6, 10.1, 10.2, 11, 14.1, 14.4, 15.4.1, 17.3.5)

S.No.	Rated Frame size Output		Full Load Speed	Full Load Current	Locked Torque in Terms of Full Load Torque	Locked Rotor Current in Terms of Full Load Current			Nominal Efficiency		
						IE2	IE3	IE4	IE2	IE3	IE4
	kW	Rev/min	A	Percent	Percent	Percent	Percent	Percent	Percent		
(1)	(2)	(3)	(4)	(5)	(6)	(7)	(8)	(9)	(10)	(11)	(12)
(i)	0.12	63	1 320	0.62	170	550	600	650	59.1	64.8	69.8
(ii)	0.18	63	1 320	0.82	170	550	600	650	64.7	69.9	74.7
(iii)	0.25	71	1 330	1.05	170	550	600	650	68.5	73.5	77.9
(iv)	0.37	71	1 330	1.4	170	600	650	700	72.7	77.3	81.1
(v)	0.55	80	1 340	1.7	170	600	650	700	77.1	80.8	83.9
(vi)	0.75	80	1 360	2.2	170	600	650	700	79.6	82.5	85.7
(vii)	1.1	90S	1 370	2.9	170	600	650	700	81.4	84.1	87.2
(viii)	1.5	90L	1 380	3.8	170	600	650	700	82.8	85.3	88.2
(ix)	2.2	100L	1 390	5.1	170	700	750	830	84.3	86.7	89.5
(x)	3.7	112M	1 410	8.1	160	700	750	830	86.3	88.4	90.9
(xi)	5.5	132S	1 420	12.0	160	700	750	830	87.7	89.6	91.9
(xii)	7.5	132M	1 430	15.4	160	700	750	830	88.7	90.4	92.6
(xiii)	11.0	160M	1 440	22.0	160	700	750	830	89.8	91.4	93.3
(xiv)	15.0	160L	1 440	30.0	160	700	750	830	90.6	92.1	93.9
(xv)	18.5	180M	1 440	36.0	160	700	750	830	91.2	92.6	94.2
(xvi)	22.0	180L	1 440	43.0	160	700	750	830	91.6	93.0	94.5
(xvii)	30.0	200L	1 450	57.0	160	700	750	830	92.3	93.6	94.9
(xviii)	37.0	225S	1 450	69.0	160	700	750	830	92.7	93.9	95.2
(xix)	45.0	225M	1 460	84.0	160	700	750	830	93.1	94.2	95.4
(xx)	55.0	250M	1 460	101.0	160	700	750	830	93.5	94.6	95.7
(xxi)	75.0	280S	1 470	134.0	160	700	770	890	94.0	95.0	96.0
(xxii)	90.0	280M	1 470	164.0	160	700	770	890	94.2	95.2	96.1
(xxiii)	110.0	315S	1 480	204.0	160	700	770	890	94.5	95.4	96.3
(xxiv)	132.0	315M1)	1 480	247.0	160	700	770	890	94.7	95.6	96.4
(xxv)	160.0	315L1)	1 480	288.0	160	700	770	890	94.9	95.8	96.6
(xxvi)	200.0	As per	1 480	348.0	160	700	770	890	95.1	96.0	96.7
(xxvii)	250.0		1 480	435.0	160	700	770	890	95.1	96.0	96.7

(xxviii)	315.0	manufac turer catalogu e	1 480	548.0	160	700	770	890	95.1	96.0	96.7
(xxix)	355.0		1 480	618.0	160	700	770	890	95.1	96.0	96.7
(xxx)	375.0		1 480	653.0	160	700	770	890	95.1	96	96.7
(xxxii)	400.0	manufac turer catalogu e	1480	As per manufa cturer catalog ue	As per manufactu rer catalogue	700	770	890	95.1	96	96.7
(xxxii)	450.0		1480			700	770	890	95.1	96	96.7
(xxxiii)	500.0		1480			700	770	890	95.1	96	96.7
(xxxiv)	560.0		1480			700	770	890	95.1	96	96.7
(xxxv)	630.0		1480			700	770	890	95.1	96	96.7
									95.1	96	96.7
(xxxvi)	710.0		1480			700	770	890	95.1	96	96.7
(xxxvii)	800.0		1480			700	770	890	95.1	96	96.7
(xxxviii)	900.0		1480			700	770	890	95.1	96	96.7
(xxxix)	1000.0		1480			700	770	890	95.1	96	96.7

## NOTES

- Output to frame size relation is maintained in accordance with IS 1231 for all motors except those marked as<sup>1)</sup>, wherein the frame size indicated is 'preferred size'.
- If the pull-up torque occurs at 0 speed, then minimum value of the starting torque permitted (subject to no tolerance) shall be 0.5 times the rated torque of IS 1231. Such cases are covered for IE classification and marking. The motor shall meet the performance parameters of the rated power (Table 1 to Table 4).
- Speeds declared above are indicative and actual values may be obtained from manufacturers' catalogue.
- For intermediate power ratings, the performance characteristics (excluding efficiency) shall be as per the nearest standard rating. The maximum rated current will be declared by the manufacturer.

**TABLE 11-C**  
**Values of Performance Characteristics of 6 Pole line operated a.c. motors**  
*(Clauses 1.2, 1.3, 1.6, 10.1, 10.2, 11, 14.1, 14.4, 15.4.1, 17.3.5)*

S.No.	Rated Frame size Output		Full Load Speed	Full Load Current	Locked Torque in Terms of Full Load Torque	Locked Rotar Current in Terms of Full Load Current			Nominal Efficiency		
						IE2	IE3	IE4	IE2	IE3	IE4
	kW		Max Rev/min	A	Percent	Percent	Percent	Percent	Percent	Percent	
(1)	(2)	(3)	(4)	(5)	(6)	(7)	(8)	(9)	(10)	(11)	(12)
(i)	0.12	63	860	0.73	160	600	650	700	50.6	57.7	64.9
(ii)	0.18	71	860	0.92	160	600	650	700	56.6	63.9	70.1
(iii)	0.25	71	860	1.1	160	600	650	700	61.6	68.6	74.1
(iv)	0.37	80	870	1.4	160	600	650	730	67.6	73.5	78.0
(v)	0.55	80	870	1.9	160	600	650	730	73.1	77.2	80.9
(vi)	0.75	90S	890	2.3	160	600	650	730	75.9	78.9	82.7
(vii)	1.1	90L	900	3.4	160	600	650	730	78.1	81.0	84.5
(viii)	1.5	100L	900	4.0	160	600	650	730	79.8	82.5	85.9
(ix)	2.2	112M	910	5.7	150	700	750	830	81.8	84.3	87.4
(x)	3.7	132S	920	8.8	150	700	750	830	84.3	86.5	89.3
(xi)	5.5	132M	920	12.9	150	700	750	830	86.0	88.0	90.5
(xii)	7.5	160 M	930	16.7	150	700	750	830	87.2	89.1	91.3
(xiii)	11.0	160L	935	23.3	140	700	750	830	88.7	90.3	92.3
(xiv)	15.0	180L	940	32.0	140	700	750	830	89.7	91.2	92.9
(xv)	18.5	200L	940	37.5	140	700	750	830	90.4	91.7	93.4
(xvi)	22.0	200L	945	44.0	140	700	750	830	90.9	92.2	93.7
(xvii)	30.0	225 M	945	59.5	140	700	750	830	91.7	92.9	94.2
(xviii)	37.0	250 M	950	72.0	140	700	750	830	92.2	93.3	94.5
(xix)	45.0	280S	960	87.0	140	700	750	830	92.7	93.7	94.8
(xx)	55.0	280 M	960	107.0	140	700	750	830	93.1	94.1	95.1
(xxi)	75.0	315S	970	145.0	140	700	770	890	93.7	94.6	95.4
(xxii)	90.0	315	970	175.0	140	700	770	890	94.0	94.9	95.6

		M									
(xxiii)	110.0	315 M1)	970	214.0	140	700	770	890	94.3	95.1	95.8
(xxiv)	132.0	315L1)	980	257.0	140	700	770	890	94.6	95.4	96.0
(xxv)	160.0	As per manufa cturer catalog ue									
(xxvi)	200.0		1 480	348.0	160	700	770	890	95.1	96.0	96.7
(xxvii)	250.0		1 480	435.0	160	700	770	890	95.1	96.0	96.7
(xxviii)	315.0		1 480	548.0	160	700	770	890	95.1	96.0	96.7
(xxix)	355.0		1 480	618.0	160	700	770	890	95.1	96.0	96.7
(xxx)	375.0		1 480	653.0	160	700	770	890	95.1	96	96.7
(xxxi)	400.0	As per manufa cturer catalog ue.	980	As per manufac turer catalo gue.	As per manufa cturer catalo gue.	700	770	890	95.0	95.8	96.6
(xxxii)	450.0		980			700	770	890	95.0	95.8	96.6
(xxxiii)	500.0		980			700	770	890	95.0	95.8	96.6
(xxxiv)	560.0		980			700	770	890	95.0	95.8	96.6
(xxxv)	630.0		980			700	770	890	95.0	95.8	96.6
(xxxvi)	710.0		980			700	770	890	95.0	95.8	96.6
(xxxvii)	800.0		980			700	770	890	95.0	95.8	96.6
(xxxviii)	900.0		980			700	770	890	95.0	95.8	96.6
(xxxix)	1000.0		980			700	770	890	95.0	95.8	96.6

#### NOTES

1. Output to frame size relation is maintained in accordance with IS 1231 for all motors except those marked as<sup>1)</sup>, wherein the frame size indicated is 'preferred size'.
2. If the pull-up torque occurs at 0 speed, then minimum value of the starting torque permitted (subject to no tolerance) shall be 0.5 times the rated torque
3. Sometimes motors are required to be offered in frame sizes higher than as stipulated in table 3 of IS 1231. Such cases are covered for IE classification and marking. The motor shall meet the performance parameters of the rated power (Table 1 to Table 4).
4. Speeds declared above are indicative and actual values may be obtained from manufacturers' catalogue.
5. For intermediate power ratings, the performance characteristics (excluding efficiency) shall be as per the nearest standard rating. The maximum rated current will be declared by the manufacturer.

**TABLE 11-D**  
**Values of Performance Characteristics of 8 Pole Line Operated a.c. Motors**

S.No.	Rated Frame size Output		Full Load Speed	Full Load Current	Locked Torque in Terms of Full Load Torque	Locked Rotar Current in Terms of Full Load Current			Nominal Efficiency		
						IE2	IE3	IE4	IE2	IE3	IE4
	kW	Rev/min	A	Percent	Percent	Percent	Percent	Percent	Percent		
(1)	(2)	(3)	(4)	(5)	(6)	(7)	(8)	(9)	(10)	(11)	(12)
(i)	0.12	71	620	0.8	150	500	550	600	39.8	50.7	62.3
(ii)	0.18	80	630	1.0	150	520	550	600	45.9	58.7	67.2
(iii)	0.25	80	630	1.2	150	520	550	600	50.6	64.1	70.8
(iv)	0.37	90S	640	1.5	150	550	600	650	56.1	69.3	74.3
(v)	0.55	90L	640	2.1	150	550	650	650	61.7	73.0	77.0
(vi)	0.75	100L	650	2.7	150	550	650	650	66.2	75.0	78.4
(vii)	1.1	100L	660	3.5	150	550	650	650	70.8	77.7	80.8
(viii)	1.5	112M	670	4.5	150	550	650	650	74.1	79.7	82.6
(ix)	2.2	132S	680	6.1	140	600	700	780	77.6	81.9	84.5
(x)	3.7	160M	690	9.8	140	600	700	780	81.4	84.5	86.8
(xi)	5.5	160M	690	14.2	140	600	700	780	83.8	86.2	88.3
(xii)	7.5	160L	695	19.0	140	600	700	780	85.3	87.3	89.3
(xiii)	11.0	180L	700	26.0	140	600	700	780	86.9	88.6	90.4
(xiv)	15.0	200L	705	35.0	130	600	700	780	88.0	89.6	91.2
(xv)	18.5	225S	705	45.0	130	600	700	780	88.6	90.1	91.7
(xvi)	22.0	225M	710	52.0	130	600	700	780	89.1	90.6	92.1
(xvii)	30.0	250M	710	70.0	130	600	700	780	89.8	91.3	92.7
(xviii)	37.0	280S	710	86.0	130	600	700	780	90.3	91.8	93.1
(xix)	45.0	280M	720	99.0	130	600	700	780	90.7	92.2	93.4
(xx)	55.0	315S	720	118.0	130	600	700	780	91.0	92.5	93.7
(xxi)	75.0	315M	730	153.0	130	600	700	780	91.6	93.1	94.2
(xxii)	90.0	315L <sup>1)</sup>	730	182.0	130	600	700	780	91.9	93.4	94.4
(xxiii)	110.0	315L <sup>1)</sup>	730	218.0	130	600	700	780	92.3	93.7	94.7
(xxiv)	132.0	315L <sup>1)</sup>	730	260.0	130	600	700	780	92.6	94.0	94.9
(xxv)	0.12	As per	730			600	700	780	93.0	94.3	95.1

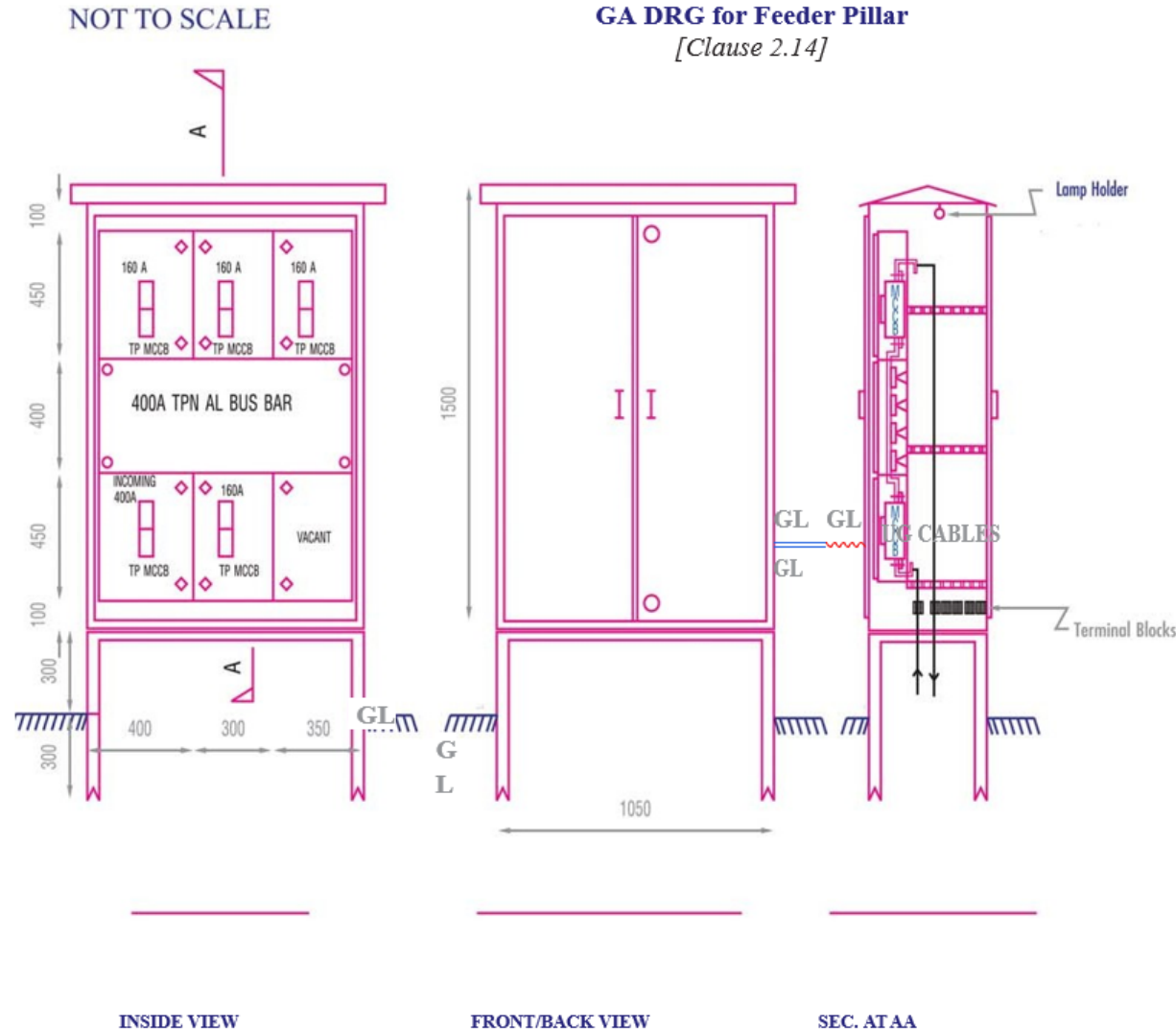
(xxvi)	0.18	manuf turer catalogu e.	730	As per manuf acturer catalo gue.	As per manufa cturer catalog ue.	600	700	780	93.5	94.6	95.4
(xxvii)	0.25		730			600	700	780	93.5	94.6	95.4
(xxviii)	0.37		730			600	700	780	93.5	94.6	95.4
(xxix)	0.55		730			600	700	780	93.5	94.6	95.4
(xxx)	0.75		730			600	700	780	93.5	94.6	95.4
(xxxi)	1.1		730			600	700	780	93.5	94.6	95.4
(xxxii)	1.5		730			600	700	780	93.5	94.6	95.4
(xxxiii)	2.2		730			600	700	780	93.5	94.6	95.4
(xxxiv)	3.7		730			600	700	780	93.5	94.6	95.4
(xxxv)	5.5		730			600	700	780	93.5	94.6	95.4
(xxxvi)	7.5		730			600	700	780	93.5	94.6	95.4
(xxxvii)	11.0		730			600	700	780	93.5	94.6	95.4
(xxxviii)	15.0		730			600	700	780	93.5	94.6	95.4
(xxxix)	18.5		730			600	700	780	93.5	94.6	95.4

## NOTES

1. Output to frame size relation is maintained in accordance with IS 1231 for all motors except those marked as<sup>1)</sup>, wherein the frame size indicated is 'preferred size'.
2. If the pull-up torque occurs at 0 speed, then minimum value of the starting torque permitted (subject to no tolerance) shall be 0.5 times the rated torque.
3. Sometimes motors are required to be offered in frame sizes higher than as stipulated in table 3 of IS 1231. Such cases are covered for IE classification and marking. The motor shall meet the performance parameters of the rated power (Table 1 to Table 4).
4. Speeds declared above are indicative and actual values may be obtained from manufacturers catalogue.
5. For intermediate power ratings, the performance characteristics (excluding efficiency) shall be as per the nearest standard rating. The maximum rated current will be declared by the manufacturer.

**Chapter 19**  
**LIST OF FIGURES**  
**FIGURE 1**

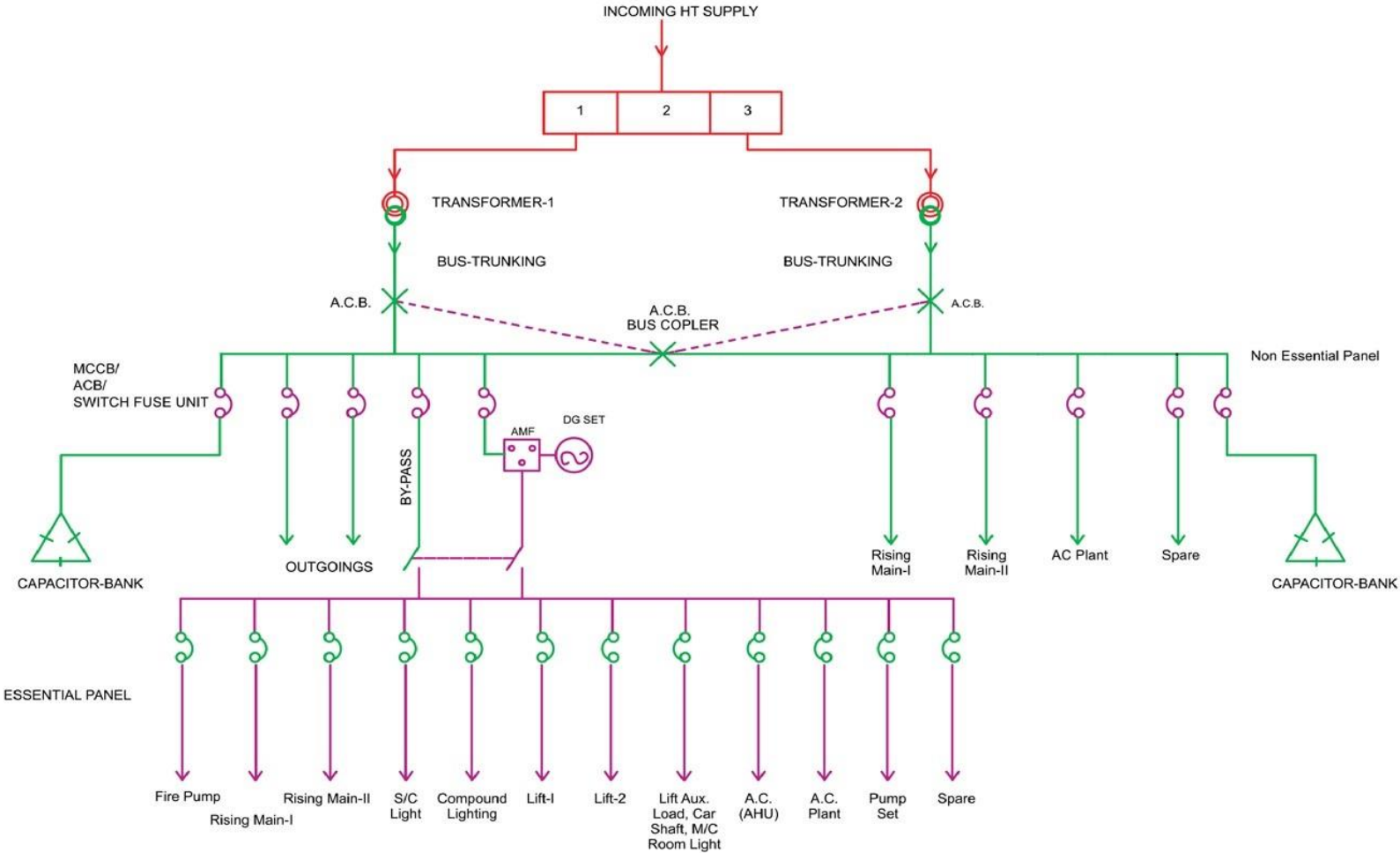
**GA DRG for Feeder Pillar**  
[Clause 2.14]



**Note :**

- (a) The fabrication will be done out of 2 mm thick CRCA sheet with double door and inbuilt locking arrangement.
- (b) All connections (incoming and outgoing) will be taken out in cable alley with suitable rated solid copper conductor.
- (c) The feeder pillar will have to be supplied with suitable pedestal (MS angle iron frame of MS channel base for grouting in the RCC and proper gland at the bottom).
- (d) The feeder pillar will be having one 10 Amp 3 pin socket outlet with 10-amp switch and one brass batten holder fitted in Metering Panel compartment and directly fed from incoming.
- (e) The depth of the feeder pillar has been considered as 400 mm
- (f) The Bus Bars made of hard drawn Tinned copper are fitted on insulated DMC supports.
- (g) Sizes and arrangement are suggestive. Exact size and arrangement will be decided by NIT approving authority.
- (h) The feeder pillar should be provided with terminal blocks for incoming & outgoing cables. From MCCB to terminal block wiring will be done with copper conductor/ suitable cable. Incoming / outgoing U.G. cable will be terminated in terminal block. This will very much reduce congestion of cables.
- (i) All dimensions in mm.

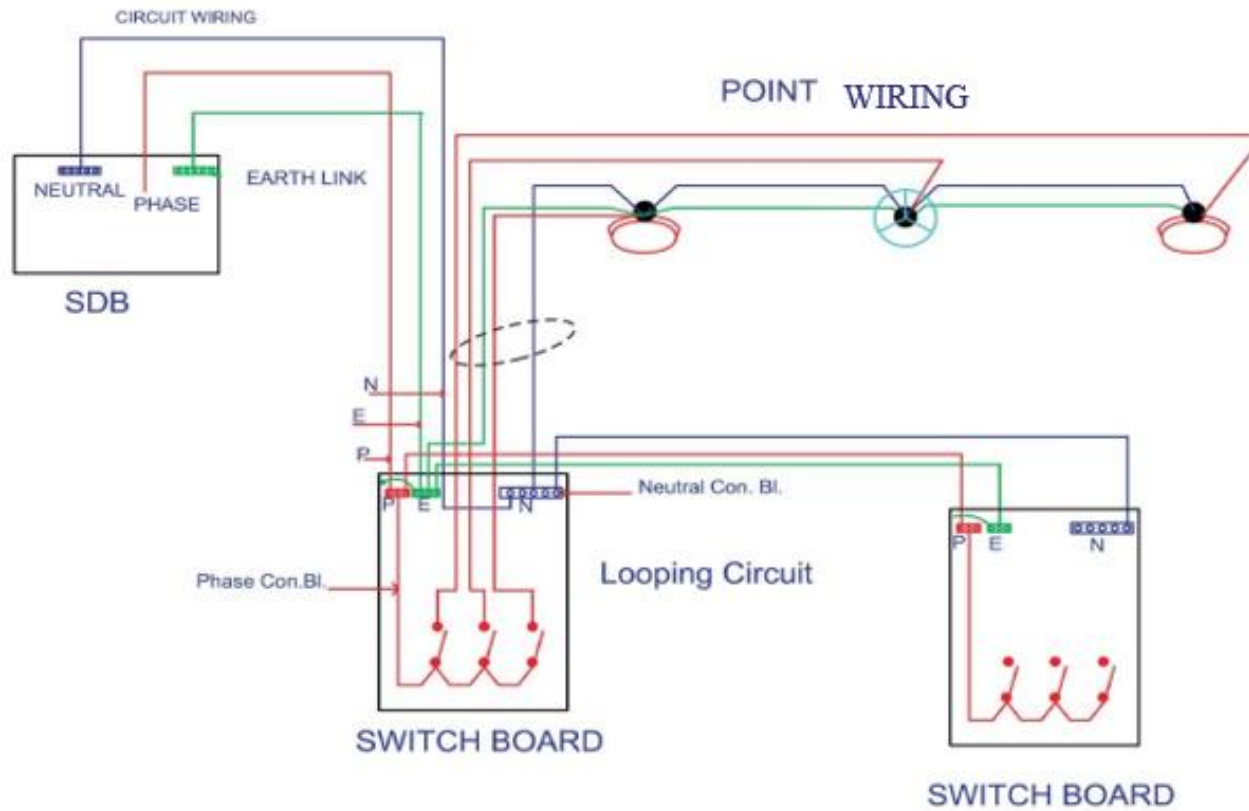
**Fig. 2**  
**Typical Schematic Diagram for Power Distribution from Sub-Station**  
*[Clause 3.1(vi)]*



**Fig. 3**

**Typical Connection Diagram from SDB to Room Switch Board**

*[Clause 3.5 (v)]*

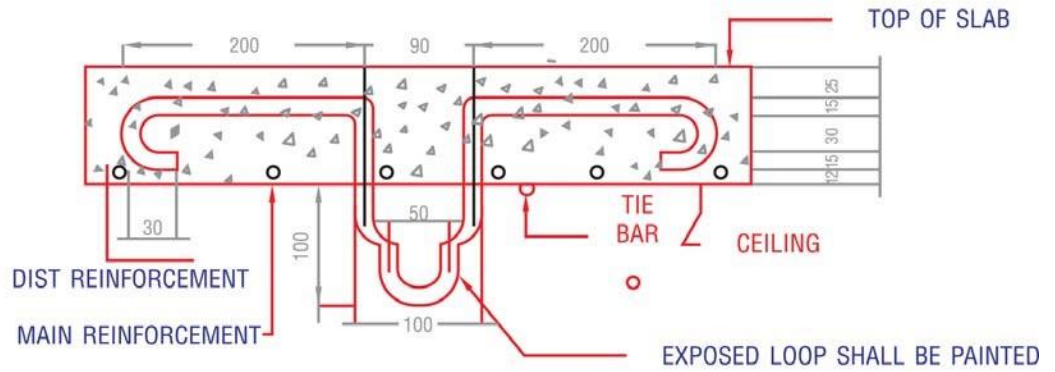


**Fig. 4**

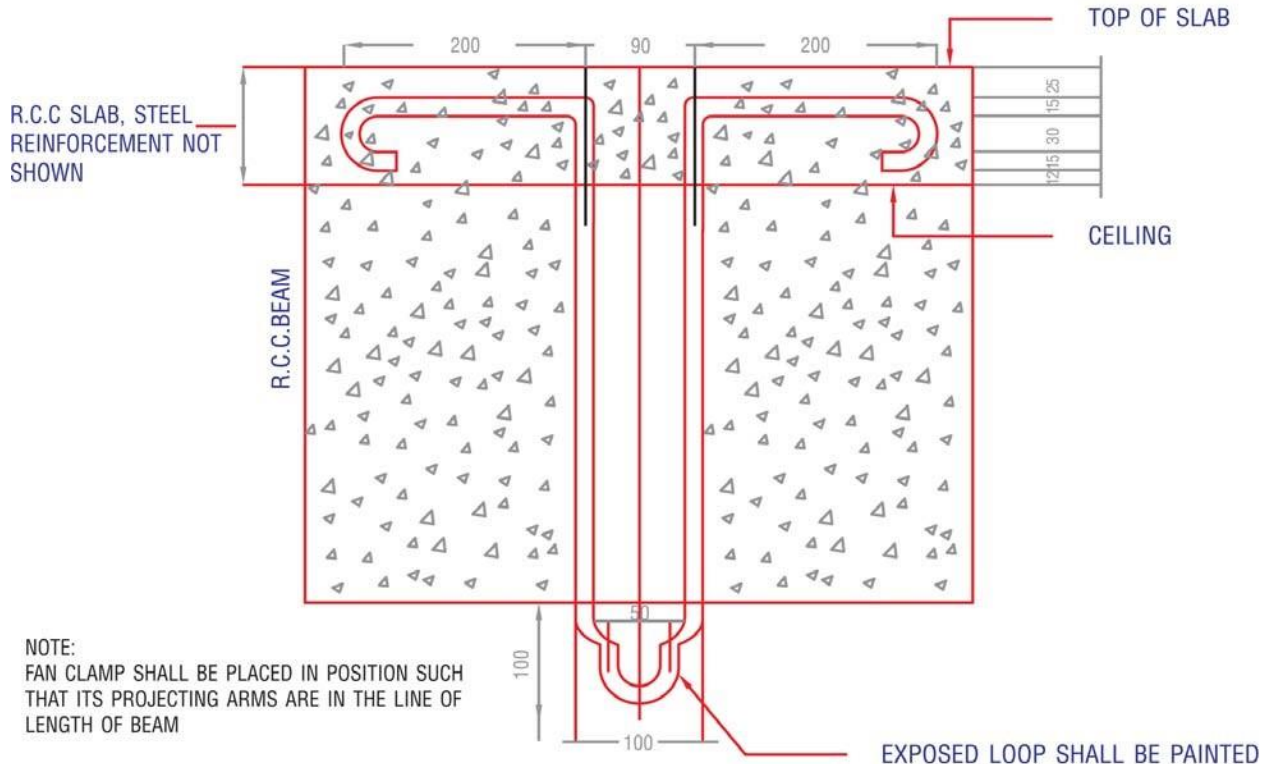
**Typical Design of M.S. Fan Clamps**

[Clause 3.16 (v)]

NOT TO SCALE



**TYPE 1 WHERE FAN CLAMP IS TO BE FIXED DURING LAYING OF R.C.C. SLAB**

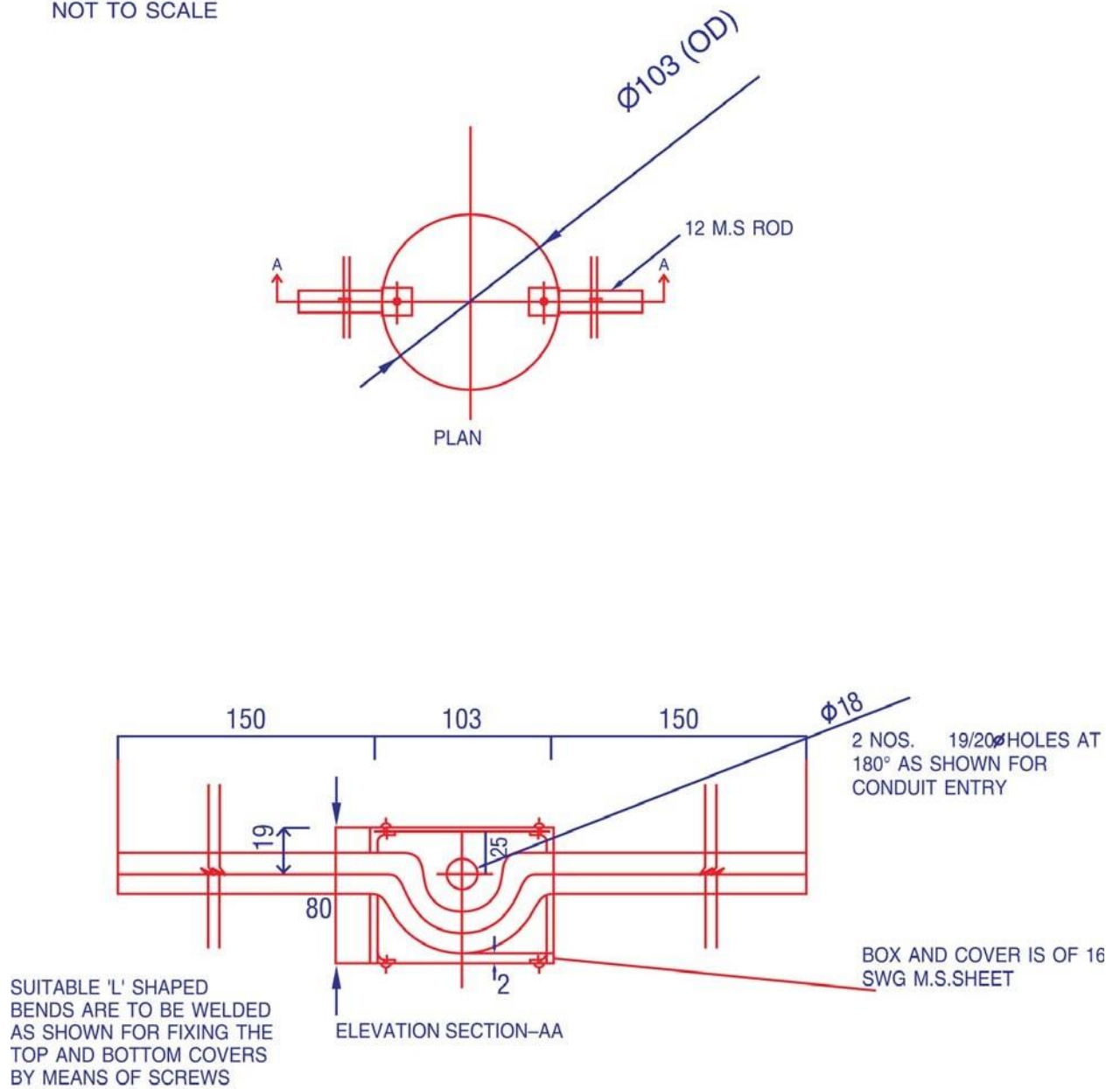


**TYPE - 2 WHERE FAN CLAMP IS TO BE FIXED DURING LAYING OF R.C.C. BEAM**

**Fig. 5**  
**Circular Box Type Fan Clamp**

[Clause 3.16 (vi)]

NOT TO SCALE

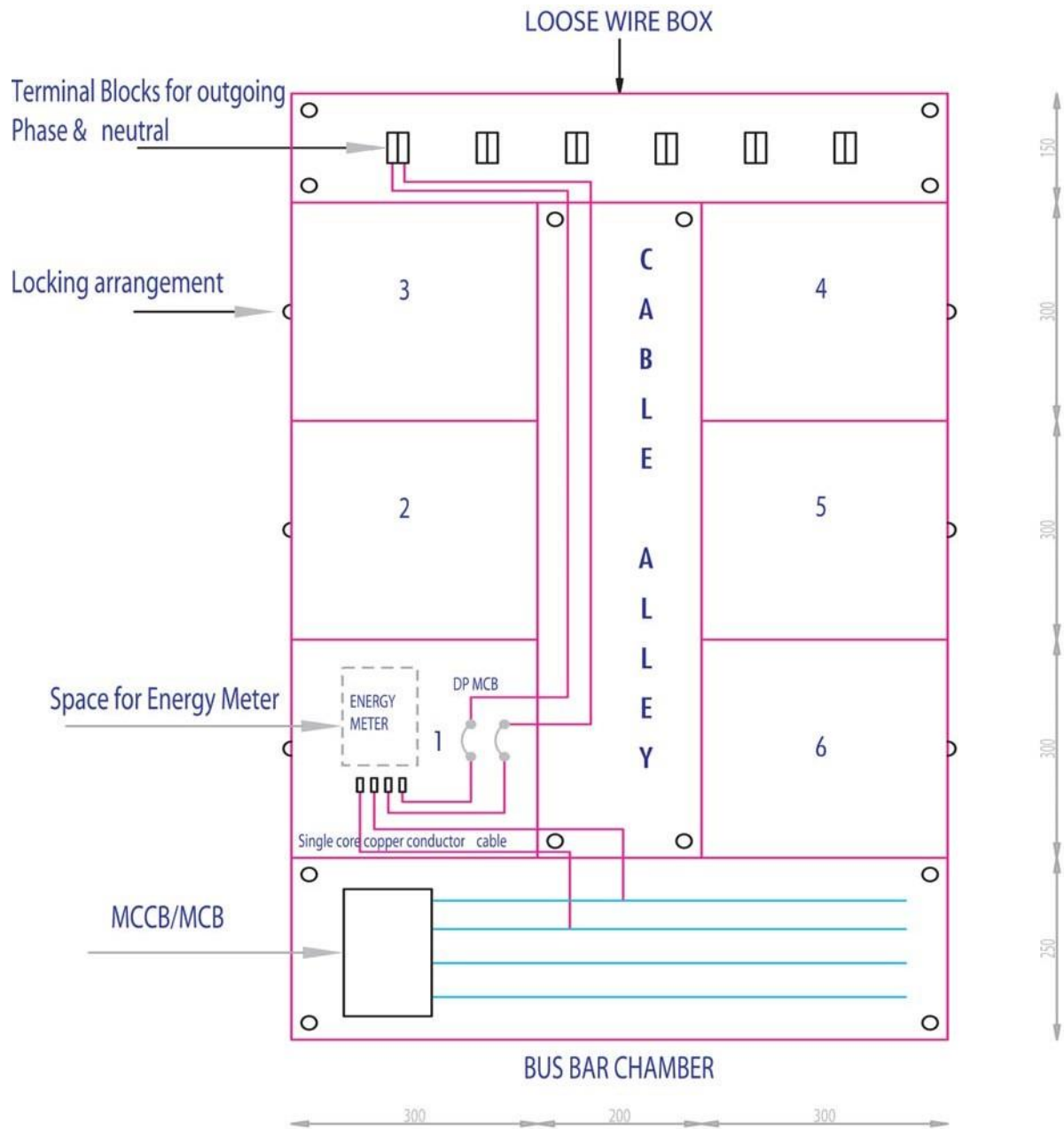


All dimensions are in mm.

**Fig. 6**

**Typical Cubical Panel for Meter Board**

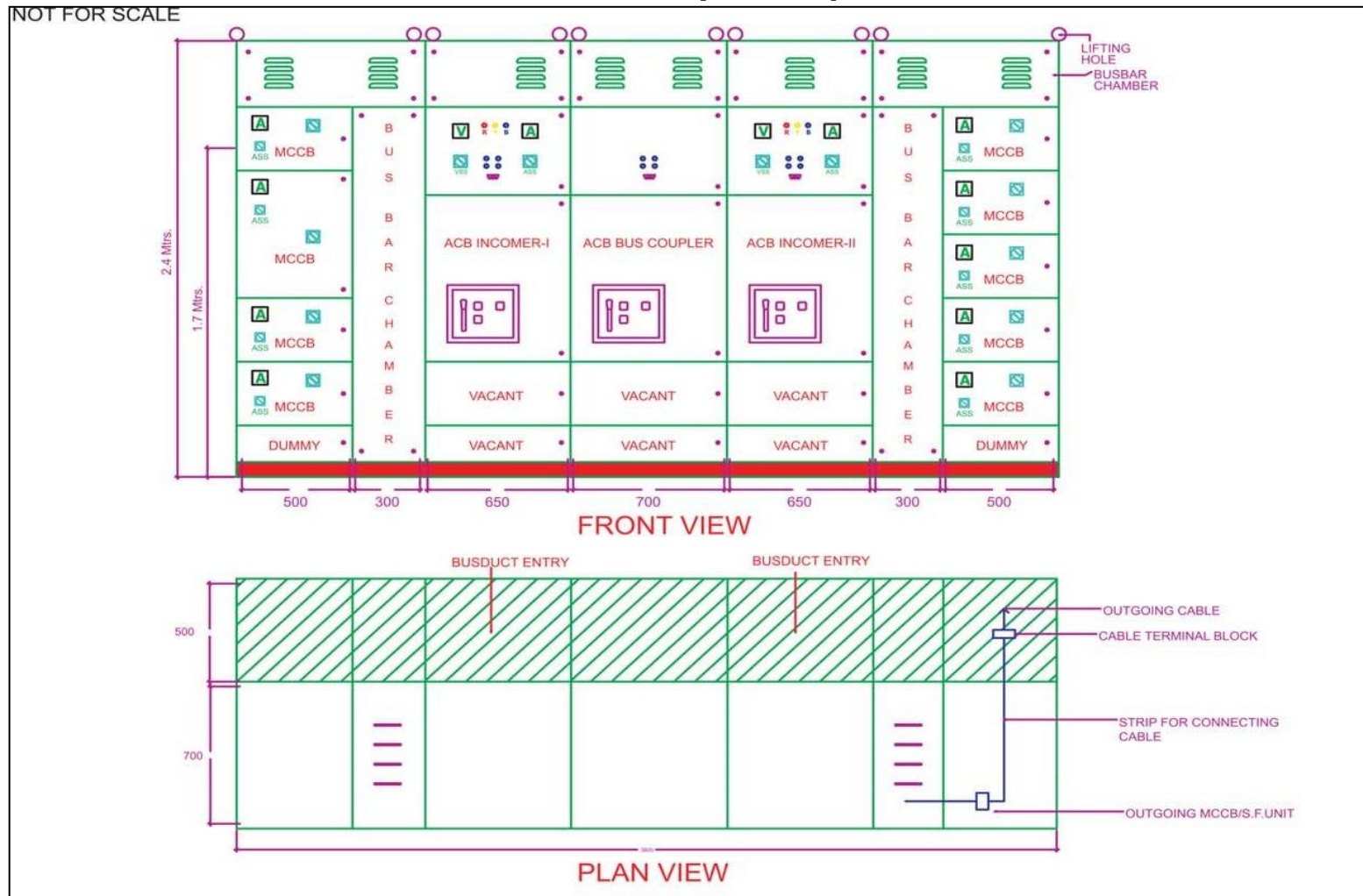
[Clause 3.20 (v)]



- All dimensions in mm.
- Individual Meter box will have locking arrangement
- Loose wire box, Cable Alley and bus bar chamber will have arrangement for sealing.
- Sizes and arrangement are suggestive. Exact size and arrangement will be decided by NIT approving authority.

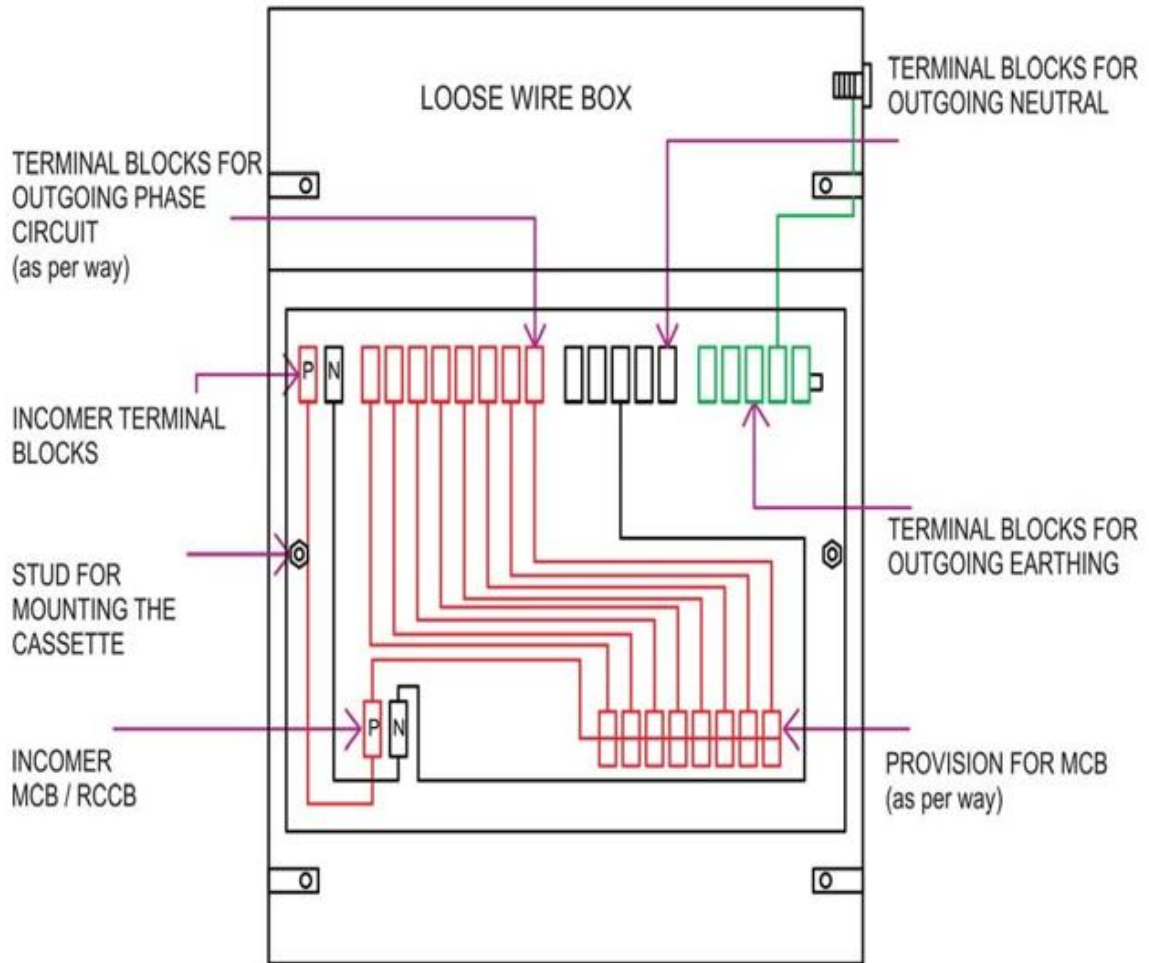
**Fig. 7**  
**Layout of Electrical Panel**

[Clause 7.1]



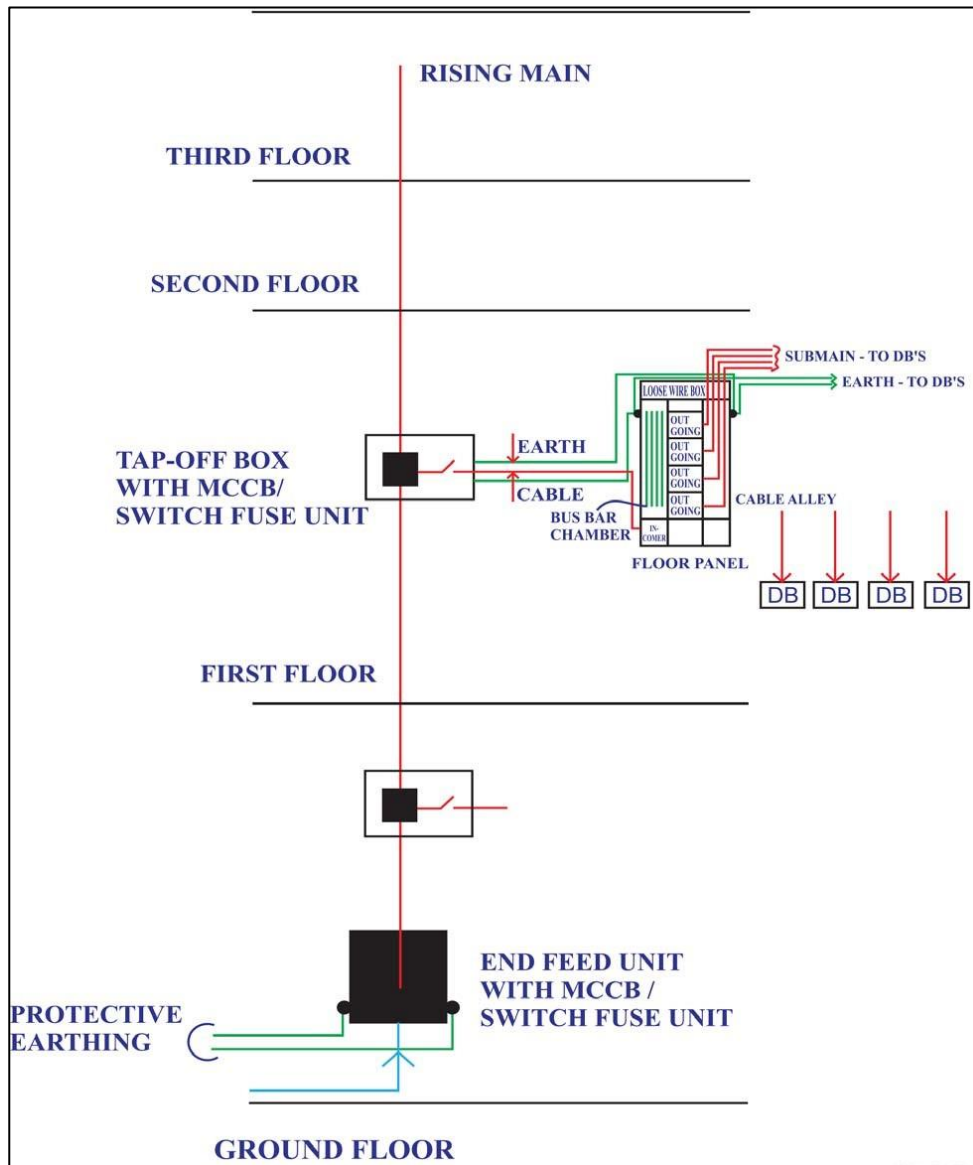
**Fig. 8**

**Pre-wired MCB Distribution Board (Single Phase)**

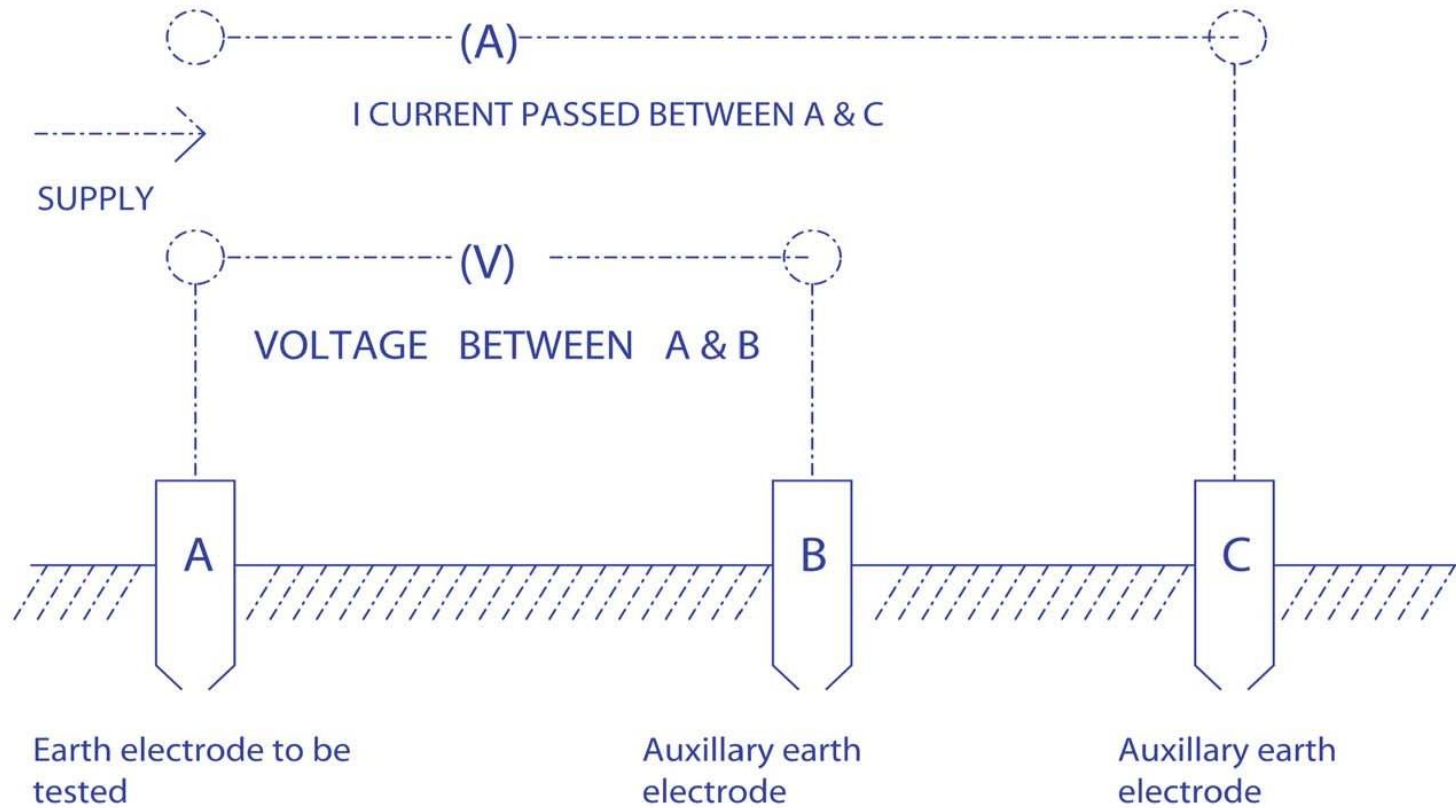


**Schematic Line Diagram**

**Fig. 9**  
**Schematic Diagram For Power Distribution System**  
*[Clause 7.2]*



**Fig. 10**  
**Earth Testing**  
*[Clause 16.5.1]*



**CHAPTER 20**  
**SPACE FOR ELECTRICAL AND MECHANICAL SERVICES IN BUILDINGS**

**COMPANION VOLUME OF GENERAL SPECIFICATIONS FOR  
ELECTRICAL WORKS**

**FOREWORD**

1. It is important to provide proper space for various E&M services at preliminary stage itself in coordination with the architect. However, it is seen in many cases, space provided for various E&M services are inadequate and in few cases they are in excess. Sometimes, some services have been left out. Based on feed back received from a number of projects, a uniform standard has been prepared.
2. The enclosed norms are intended only to serve as guidelines, and should not come in the way of modifications / improvements or different approach as required for specific applications as per the judgement of planning engineers.
3. Suggestions / comments will be gratefully received.
4. This has been approved by 38th Specification Committee held on 9th/10th October,2002 vide agenda Item 30.0.5.

## SPACE FOR ELECTRICAL AND MECHANICAL SERVICES IN BUILDINGS

### 1. INTRODUCTION

E&M services generally provided in a building:

- (a) Electric sub-station, power distribution system.
- (b) Generating sets.
- (c) Lifts.
- (d) AC plant including central plant, package plant, split /window AC units.
- (e) Ventilation system.
- (f) U.P.S. / Voltage stabilizer.
- (g) Water supply pumps.
- (h) Wet riser system for fire protection.
- (i) Fire detection, alarm, PA system for fire protection.
- (j) Communication system.
- (k) Computer cabling and allied works.
- (l) Building security system including CCTV, access control, burglar alarm system.
- (m) Building automation system.
- (n) External lighting, road lighting, compound lighting, garden lighting, area lighting, high mast lighting and other specialized lighting.
- (o) Auditorium lighting, acoustics, stage lighting and sound system.
- (p) Swimming pool equipments etc.

All these services require close coordination between civil, architectural and electrical wings right from conceptual stage. Unless proper space is provided for these services, they can't be provided at construction stage without adversely affecting the aesthetics of the building and functional efficiency of the services. Many services can't be provided at all in absence of proper planning of space for various E&M services.

### 2. ELECTRICAL SUB-STATION

#### (a) Space for:

- HT panel (both supply and CPWD).
- Transformers.
- L.T. panel.
- Essential L.T. panel.
- Power factor correction panel.
- Generating sets.
- P.O.L. Store / other store.
- Supervisor room, toilet, workers rest room.
- HT voltage correctors.
- Voltage stabilizers.
- UPS system including battery room. Other equipments as required.

- (b) Ventilation.
- (c) Approach road around Sub-station.
- (d) Extract of Table A & B of Appendix IV of CPWD Electrical Specification Part IV (Sub-station) 2013

*Area for Sub-Station*

The minimum sub-station and transformer room area required for different capacities are tabulated for general guidance. Actual area will however depend upon the particular layout and site constraints.

The clear height required for Sub-station equipments shall be a minimum of 3.6 m.

**TABLE 1**

<i>Sub-Station with transformer capacity of</i>	<i>Total transformer room area required</i>	<i>Total sub-station area required i/c HVMV panel transformers but without generators</i>	<i>Suggested minimum face width</i>
2*500 kVA	36.00 sqm	130.00 sqm	14.5 m
3*500 kVA	54.00 sqm	172.00 sqm	19.0 m
2*800 kVA	39.00 sqm	135.00 sqm	14.5 m
3*800 kVA	58.00 sqm	181.00 sqm	19.0 m
2*1000 kVA	39.00 sqm	149.00 sqm	14.5 m
3*1000 kVA	58.00 sqm	197.00 sqm	19.0 m

*Area for Generating Sets*

Additional area that is required for one generator is given below:

**TABLE 2**

<i>Capacity</i>	<i>Area</i>
25kW	56.00 sqm
48kW	56.00 sqm
100 kW	65.00 sqm
150 kW	72.00 sqm
248 kW	100.00 sqm

The clear height required for the generating set room shall be a minimum of 3.6 m upto 100 kW capacity and 4.57 m for higher capacities.

- (e) Location of Sub-station:
  - (i) Avoid basement due to likely flooding during rains (there is hardly any basement sub-station/AC plant, which is not affected by substantial damaged ueto flooding).
  - (ii) No parking in front of transformer and other equipments.
  - (iii) Easy approach to equipments.
  - (iv) Closer to the electrical load center and preferably in the ground floor.

(f) Future Expansion:

The sub-station design should take into account reasonable augmentation of equipments in future.

(g) Security Precaution:

Sub-station is the heart of electrical system. Wherever required, security measures like boundary wall and lockable gate may be provided so that unauthorized entry to sub-station can be prohibited.

*Annexure I, II & III for Sub-Station may be seen.*

### 3. WET RISER & WATER SUPPLY PUMPHOUSE

Preferable to have under ground pump house by the side of U.G. water reservoir to ensure flooded suction. Water supply pump sets to be combined. Provide suitable ramp approach 1.5 m wide with suitable slope for easy access of heavy equipments and inspection personnel.

Roof slab may be 500 mm above ground level with ventilators. Provide suitable water proofing to prevent seepage of water into pump house.

Preventive measures to be taken so that during heavy rains, rainwater does not get into pump house.

Extract of Para 1.3.3 of CPWD Specifications Part V: Wet Riser System for Fire Fighting:

*Location and Requirements*

(a) *Under Ground Static Storage Tank and Pump House:*

Following aspects shall be considered in deciding the location of the underground static water storage tank and the wet riser pump house :

- (i) Easy accessibility for fire fighting operations.
- (ii) Proximity of fire pump house to the static tank.
- (iii) Ease in bringing and removing equipment.
- (iv) Pump house not being prone to flooding by rainwater, subsoil water.
- (v) Protection of the pump house from any falling masonry and the like occasioned by fire.
- (vi) Adequate ventilation for engine aspiration and to limit the temperature rise in pump house on continuous operation.
- (vii) Aesthetics.

To protect the pump house, it should preferably be located atleast 6 m away from the building. Where this is not possible, this shall be enclosed with suitable masonry structure as a part of the building to prevent spread of fire into the pump room and provide safe operation.

The fire pump house should be located such that the suction for the pump is flooded. Where this is not practical, the pump house may be constructed with negative suction for pump, with suitable automatic priming arrangement. The size of the fire pump house should be 5.5 m x 8 m x 3.5 m, where engine driven fire pump, electric motor driven fire pump and pressurization pump are installed.

The capacity and design of the static tank shall be in accordance with the provisions of National Building Code Part IV - Fire Protection and the local Bylaws as applicable. (See Appendix -II of CPWD Specification Part-V).

*Annexure IV, V & VI for Pump House & Tank may be seen.*

*(b) External Piping and Hydrants:*

External hydrants shall be located within 2 m to 15 m from the building to be protected such that they are accessible and may not be damaged by vehicles. A spacing of about 45 m between hydrants is generally adopted.

*(c) Internal Riser and Hydrants:*

Normally one wet riser is required for every 1000 sqm of covered area. However, the maximum distance that can be served shall be 30 m from the riser.

#### **4. LIFTS**

Check Sizes As Per B.I.S.

*(a) Capacity & number of lifts.*

(A minimum capacity of 13 passenger lift for office bldg. and 8 passenger lift for residential building). Ensure provision of goods lift.

*(b) Lift well size.*

*(c) Pit depth.*

*(d) Machine room size.*

*(e) Over head.*

*(f) The floor of lift machine room shall be designed for a uniform load of 1000kg/sqm.*

*(g) Lift pit to be waterproofed.*

*(h) No structural member intrusions into lift well, like column, beam projections which compromise lift well dimensions.*

#### **5. FIRE CONTROL ROOM / TELEPHONE ROOM**

*(a) Telephone room: 4 m x 3m.*

*(b) Fire control room: 4 m x 3 m preferable location near entrance lobby.*

**Note:** Fire control room is a statutory requirement as per national building code.

Annexure VIII may be seen.

## 6. AIR CONDITIONING

- (a) Air-conditioning is maintenance of specified inside conditions: temperature, relative humidity, air changes and air quality.

Air-conditioning also includes winter heating and clean air system.

- (b) Depending upon specific requirements, following systems of air-conditioning are followed:

(i) Window type AC Units.

(ii) Split type AC Units.

(iii) Package type AC Units.

(iv) Central AC System.

- (c) Their brief applications are as below:

(i) *Window type Units*: Suitable for individual isolated rooms. Consumes very high amount of power. No relative humidity control. Very little control over air quality. Suitable for area upto 100Sqm.

(ii) *Split Units*: They are same as window type units, except that the compressor units are located away from evaporator (fan) units. The noise of compressor is kept away. Energy wasteful.

(iii) *Package type*: They are mini and compact central plants available up to 10-Ton capacity. This system is suitable for areas between 100 to 1000sqm.

(iv) *Central AC Plants*: They are suitable for large areas. Excellent control over temperature, humidity, clean air, air changes, noise control, uniform distribution and have energy efficiency. A properly designed central AC system will be reliable, effective and efficient. Hence for air-conditioning areas in excess of 1000 sqm, central AC plant is preferred.

- (d) Comparison of Systems

**TABLE 3**

	<b>Normal Life</b>	<b>Energy Consumption Index</b>	<b>Humidity Control</b>	<b>Air Changes</b>
Central AC Plant	20 Yrs	100	Yes	Yes
Package Plant	10 Yrs	130	Yes	Yes
Split/ Window AC Unit	7 Yrs	150	No	No

The central plants are designed with suitable standby systems to give reliable service. Properly designed buildings also will reduce ingress of heat, hence the heat load also is reduced by as much as 25%, in case of central plant.

For example, a properly designed building with 200 ton AC load, working 8hr/day,250 days/ year will consume approximately 4 Lac units of electricity per year which comes to Rs.16 Lac/year. If the same building is air-conditioned with window type AC units/ split type units, without proper insulation of the building, the energy cost is likely to be 60% more.

- (e) The space & structural requirements for air-conditioning works vary considerably with the systems adopted. It is therefore advisable to study individual cases and decide accordingly in consultation with the manufacturers, if necessary. However, a general guideline is given in Annexure XIII for the purpose of preliminary design/drawing.
- (i) Space for:  
A/C plant room, cooling tower, make up water tank, air handling units, shaft for chilled water lines.
- (ii) Shaft, space, false ceiling for ducts, air tightness of doors & windows in air- conditioned areas & AHU rooms.
- (iii) Clear height of 3.4 m in corridor/ air-conditioned space, as the case may be to accommodate supply air duct and return airpath.
- (iv) Thermal insulation of ceiling and walls of air-conditioned area/ AHU rooms wherever necessary.
- (v) Acoustic insulation for AHU rooms.
- (vi) Co-ordination of false ceiling work.
- (vii) Availability of water supply for cooling towers.
- (viii) Ventilation of AC plant room.
- (ix) Approach road around plant room.
- (x) Drainage of AHU room, fresh air opening in AHU room.
- (xi) Opening for WT AC units. (Annexure XII).
- (xii) Space for split AC condensing units and route and entry for inter-connection of indoor & outdoor units.

## 7. SHAFTS

### (a) Shaft Details:

- (i) **Electrical rising main shaft:** 2.2x0.8m for accommodating normal & essential supply rising mains.
- (ii) **Wet riser shaft:** 1.2 m \* 0.8m.
- (iii) **Telephone shaft:** 0.6 m \* 0.3m
- (iv) **Fire alarm shaft:** 0.6 m \* 0.3m.
- (v) **Computer cabling shaft:** 0.6 m \* 0.3m.

*Please see Annexure VII & VIII.*

### (b) Door for Shafts:

Door for Wet riser shaft may be provided as per Annexure XI. Provide steel door frame & steel doors with locking arrangement for other shafts. Doors to open towards corridor.

*Please see Annexure X & Annexure XI.*

**Note:** No wooden doors shall be used since they pose fire risk.

### (c) Location of Shafts:

- (i) **Fire Alarm Shaft:** It shall be located in the lift lobby/common area and preferably can start from fire control room.

- (ii) **Telephone Shaft:** Preferable to start from telephoneroom.
- (iii) Shaft shall be in common area and not inside any room, so that they are accessible to service personnel even after office hours.
- (iv) Away from water/ drainage shafts. Not to be exposed to rains etc.

## **8. CABLE ENTRY PIPES**

Provide For:

- (a) Cable entry into sub-station.
- (b) Sub-station to rising main shafts.
- (c) Cable entry into telephone room.
- (d) Wet riser pump to wet riser shafts.

## **9. S.D.Bs**

Shall be recessed in walls nearest to load and niches for the same are not required.

## **10. FALSE CEILING IN CORRIDOR**

When services like telephone/ computer/ electrical cables have to be taken in the corridor, it is better to provide false ceiling, so that the service cables are properly covered and don't present a shabby look. Also it helps in laying additional cables in later years.

## **11. FALSE CEILING IN ROOMS**

Light fittings, AC diffusers, fire detectors, P.A. speakers will be fixed on false ceiling. Therefore it is necessary to locate all these fixtures to give a symmetrical and aesthetic look. False ceiling materials should be of fire resistance type.

## **12. CHECKLIST**

- (a) Electrical sub-station.
- (b) Wet riser pump house. Water supply pumphouse.
- (c) Lift:
  - (i) Number.
  - (ii) Capacity.
  - (iii) Shaft dimensions.
  - (iv) M/c. Room dimensions.
  - (v) Pit depth.
  - (vi) Overhead.
  - (vii) No intrusion of structural members into lift shaft /pitch etc.
  - (viii) Water proofing of lift pit.
- (d) Fire control room and telephone room.
- (e) Shafts:

- (i) Electrical rising main shaft.
- (ii) Wet riser shaft.
- (iii) Telephone shaft.
- (iv) Fire alarm shaft.
- (v) Computer cabling.
- (f) Doors for shafts.
- (g) Location of shafts.
- (h) Service-entry pipes.
  - (i) Central air-conditioning:
    - (i) AC plant room.
    - (ii) Cooling tower location.
    - (iii) AHU room.
    - (iv) AHU room drainage, fresh air opening.
    - (v) Chiller pipes shaft, chiller pipe entry into building.
    - (vi) False ceiling co-ordination.
    - (vii) Ceiling height to accommodate ducting.
    - (viii) Water requirement.
    - (ix) Routes of piping/cable.
    - (x) Thermal/acoustic insulation.
    - (xi) Airtightness of windows/ doors. It is proper to provide double glazed window panes for insulation.
  - (j) Split AC Units:
    - (i) Location of condensing units.
    - (ii) Interconnection of condensing and indoor units finalization of route.
  - (k) Window Type AC Units: Window frames compatible with opening for window type AC units.
  - (l) Corridor false ceiling to cover service cables.
  - (m) False ceiling to symmetrically provide for AC diffuser, fire detectors, light fittings and P.A. speakers. False ceiling material should be fire resistant.
  - (n) Water supply co-ordination: Drinking water, toilet water, horticulture, firefighting, air-conditioning, assessment of water requirements, location of tanks, O.H. tanks and pumping arrangements.
  - (o) Co-ordination of various service pipe/ cable routes: Coordination of water supply, storm water, drain water, sewerage, electricity, telephone, computer, wet riser pipes, air-conditioning cables/ pipes fixing their routes, so that the service/ cable pipes are coordinated and various executing agencies don't clash over routes.



# **EDITORIAL TEAM**



**SH. VIKAS RANA**  
**CE, CSQ (E)**



**SH. VIMAL KUMAR**  
**CE, (E)**



**SH. RAMAYAN PRASAD GUPTA**  
**SE (E) TAS, CSQ**



**SH. ASHOK KUMAR MEENA**  
**EE(E) TAS, CSQ**



**SH. SANDEEP KUMAR DAS**  
**AE(E)TAS, CSQ**