



# **SAFETY, HEALTH AND ENVIRONMENT HANDBOOK 2019**



Director General, CPWD, New Delhi





**SAFETY, HEALTH AND ENVIRONMENT  
HANDBOOK  
2019**

Published under the Authority of  
Director General  
Central Public Works Department  
Ministry of Housing and Urban Affairs



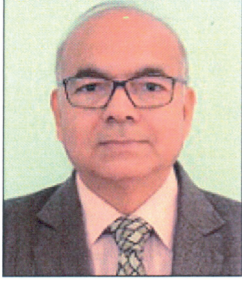

**PRABHAKAR SINGH**  
Director General



भारत सरकार  
Government of India



केन्द्रीय लोक निर्माण विभाग  
निर्माण भवन, नई दिल्ली-110011  
Central Public Works Department  
Nirman Bhawan, New Delhi-110011  
Tel : 23062556/1317, Fax : 23061884  
E-mail : cpwd\_dgw@nic.in

## FOREWORD

It gives me immense pleasure to note that a handbook on "Safety, Health & Environment" is being brought out by the CPWD to facilitate Field Engineers and Contractors to address safety and health issues of workers at Construction sites.

Over the years, CPWD has brought out many publications such as Delhi Schedule of Rates, CPWD Works Manual and CPWD Specification etc. but till now there is no book brought out by CPWD on safety and Health issues of workers at work places, though CPWD Safety code was available in General Conditions of Contract.

Safety, Health & Environment handbook provides detailed procedure required to be followed by Engineers and Supervisors at work site.

This hand book is made basically for use in CPWD, though it may be beneficial to other Government Department and Public Sector Undertaking, who have adopted similar system of working. I am sure this will be well received by all concerned.

I would like to express my thanks to Dr. K. M. Soni, ADG(Tech.), CPWD and his entire dedicated team. Due to their team efforts this publication could become possible in a short time.

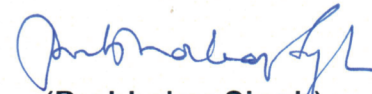
  
(Prabhakar Singh)

Place: New Delhi  
Dated: July 2019



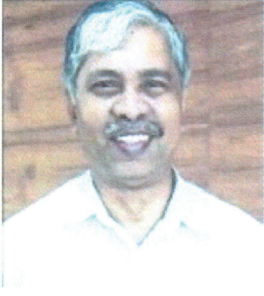

**Dr. K.M. Soni**  
Additional Director General (Tech)



भारत सरकार  
Government of India



Central Public Works Department  
Nirman Bhawan, New Delhi

## Preface

Safety in construction is required at planning, execution and Maintenance stages. It has to be planned and implemented in the works for the safety of personnel, assets and environment. Simultaneously, health of the personnel and workers during construction and occupants after the construction of building has to be considered. Thus, concept of **Safety, Health and Environment (SHE)** has to be kept in consideration by architects and Engineers from conceptual to completion stage and during maintenance period.

To help the planners, architects and engineers in implementing SHE provisions, this hand book has been prepared. We would be obliged if the comments for its improvements are sent to us so that the same can be incorporated in next version.

I am thankful to Shri Prabhakar Singh, DG, CPWD for guidance and co-operation and my entire team who worked very hard to bring out this useful document.

(Dr. K.M. Soni)  
Addl. DG (Tech)

Place: New Delhi

Date: July, 2019







## Table of Content

1	INTRODUCTION DOCUMENT CONTROL AND PURPOSE OF HAND BOOK	1
2	REFERENCES AND DISTRIBUTION OF THIS HANDBOOK	3
3.	DEFINITION OF TERMS	6
4	GENERAL	8
5	GENERAL DUTIES OF CONTRACTOR'S AND OTHERS	9
6	SAFETY TRAINING	18
7	SAFETY PROMOTION AND PENALTY	22
8	INDUCTION TO THE EMPLOYEES AND VISITORS	36
9	EMERGENCY PREPAREDNESS AND RESPONSE	36
10	HAZARDS AND RISK MANAGEMENT	38
11	SAFETY INSPECTIONS AND FOLLOW UP ACTION	43
12	CONTACTOR'S SITE SAFETY COMMITTEES	46
13	REPORTING OF ACCIDENTS AND DANGEROUS OCCURRENCES	48
14	ACCIDENT INVESTIGATION	50
15	ACCIDENT STATISTICS	51
16	RISK ASSESSMENT	52
17	WORKING HOURS	56
18	SMOKING	57
19	FIRST AID AND TRAINING	57
20	EMERGENCY PREPAREDNESS PLANS	57
21	SAFETY SIGNAGE	58
22	INDUSTRIAL HEALTH AND WELFARE	60
23	CONSENT TO WORK	82
24	NON CONFORMANCE REPORT	84

25	WASTE MANAGEMENT	84
26	PROTECTION OF WATER COURSES	85
27	EMMISSION REDUCTION	87
28	PAPER SAVING	88
29	ENERGY CONSERVATION	88
30	WATER CONSERVATION	89
31	CONTRACTOR ASSESSMENT	89
32	WORKING AT HEIGHT	89
33	EXCAVATIONS	95
34	LIFTING OPERATIONS	100
35	VEHICLE TRAFFIC MANAGEMENT	102
36	PEDESTRIAN SEGREGATION	103
37	WORK IN CONFINED SPACES	104
38	SITE ELECTRICITY	106
39	WELDING AND CUTTING	109
40	MACHINERY	111
41	HEAVY PLANT OPERATIONS	112
42	TUNNELLING OPERATIONS	113
43	DEMOLITION	115
44	FALSEWORK / FORMWORK	115
45	WORK ADJACENT TO LIVE ROADWAYS	116
46	PERSONAL PROTECTIVE EQUIPMENT	117
47	FIRE PRECAUTIONS	120
48	SITE PERIMETER HOARDING	122
49	TRAFFIC MANAGEMENT	122

50	VISITORS TO SITE	123
51	SAFETY MEETING AND SELF INSPECTION	123
52	LADDER SAFETY	124
53	HOUSEKEEPING	126
54	ERECTION	128
55	PNEUMATIC COMPRESSOR	130
56	CONCRETE BATCHING AND MIXING PLANT	131
57	TRANSIT MIXER	132
58	MIXER	133
59	CONCRETE PUMP	133
60	CONCRETE VIBRATOR	134
61	CRANE	135
62	MOBILE CRANE	136
63	BENDING AND CUTTING MACHINE	137
64	D.G SETS	137
65	USE OF COMPRESSES GAS CYLINDER	138
66	MONITORING AND AUDIT	139
67	SECURITY PLAN	140
68	CHILD LABOR (BELOW 18 YEARS OF AGE AND PHYSICALLY CHALLENGED	144
69	PERSONS UNDER THE INFLUENCE OF ALCOHOL OR DRUGS	145
70	PERSON WITHOUT PHOTO IDENTITY	145
71	ENVIRONMENT MANAGEMENT PLAN	145

## **INTRODUCTION**

This Handbook in conjunction of emergency action plan intend to define minimum requirement of safety, health and environmental management system to be implemented on in CPWD works to maintain high standards of SHE at construction sites. . It is intended to be used by engineers, architects and contractors during planning and execution stages.

It is imperative, that the engineers and Contractor carefully study this document and makes all provisions implemented in the for conformance to the working in all clauses within this document, . The Contractor shall deemed to have allowed for the cost of adopting these Minimum Construction Site Safety provisions throughout the course of the works, and get them strictly followed by all site personnel for whom the Contractor is responsible, including suppliers who visit site, visitors of the Contractor and Associated Contractors/Agencies s and their personnel.

The Contractor is to comply with the requirements of this document in addition to other documents forming the Contract, including the General Conditions of Contract, and any further such safety precautions required by Statutory Authorities. These precautions are additional those necessary for the safety of occupiers of buildings and compliance with these rules shall not relieve the Contractor of any responsibility for taking all precautions as per the contract and Rules/Acts.

This Handbook has system wide application, and therefore not all of these actions will apply to all Contractors. Each Contractor shall develop his own contract specific Site SHE Plan, which will represent his approach to the management of Safety, Health and Environment (SHE) on his work, sites under the Contract with CPWD.

This Handbook has been produced in order to outline the minimum health and safety, standards that shall be required by CPWD management to be followed. Furthermore the Handbook has been developed to give guidance and assistance to the Contractors working in CPWD Works in the development and production of their Site SHE Plans, to satisfy the required Safety, Health and Environment standards established by the Contract Conditions and the Contractual Requirements. This Handbook represents the minimum standards required and each Contractor is encouraged to expand and improve upon it.

The Contractor shall provide all necessary fencing, or barricading and lights to protect the public against accident or injury, and shall be bound to bear the expenses of every legal suit, action or other proceeding at law that may be brought by any person for injury sustained owing to neglect of the above precautions, and to pay any damages and cost which may be awarded in any such suit, action or proceedings to any such person or which may with the consent of the Contractor be paid to compromise any claim by any such person. The Contractor shall never in the performance of the Contract, in any

manner endanger the safety or unlawfully interfere with the convenience of the public.

This Handbook is not intended to replace existing standards that are currently in force in India. However, it is intended to support the standards and to highlight to Contractors the areas of concern and importance of SHE that shall be addressed in their respective Site Safety Plans in order to establish good health and safety practices.

## **DOCUMENT CONTROL**

This SHE Plan is a controlled document. It presents an outline of the health and safety management system to be used at CPWD, projects covering the requirements of Local and International SHE management system.

The plan is subject to amendment during the execution of the Works as a result of periodic review and whenever circumstances require. Revisions will be issued in accordance with the system procedure Document Control whenever the main text changes or when an appendix is added or removed. Revised appendices for substitution will be issued separately.

## **Purpose of Handbook**

- 1 CPWD intends to raise the standards of health and safety on construction sites to a level that will be recognised as the best in India and comparable to the highest standards achieved in country.
- 2 This can only be achieved if there is a commitment from all parties involved in the construction and management of the Project, from the most senior level of managers within the CPWD and the Contractors, to the workers on the sites.
- 3 This document will be abided by all the full support of all of the CPWD Project Team failing to give support to it shall be subject to internal discipline.
- 4 The CPWD shall actively support the efforts and initiatives that are instigated by the Contractors and Associated Contractors/Agencies in their efforts for achieving high standards of health safety and environment on the Project.
- 5 The provisions that are needed to make and achieve a high standard of health and safety, are well known to most of CPWD engineers and architects , it is however the level of commitment that is demonstrated that shall determine whether or not we succeed.
- 6 This Handbook represents the minimum standards that CPWD intend to accept on matters of Safety and Health. The Department will use its best endeavours to ensure that all of the Contractors engaged employed on the Project achieve these Standards

- 7 This Handbook has been produced in order to outline the minimum health and safety, standards that shall be required by CPWD during the construction of the project. Furthermore the Handbook has been developed to give guidance and assistance to the architect, engineers and respective Contractors in the development and production of their Site Health and Safety Plans, to satisfy the required health and safety standards established by the Contract Conditions and the Department's Requirements. This Handbook represents the minimum standards required and each Contractor is encouraged to expand and improve up on it.
- 8 This Handbook is not intended to replace existing standards that are currently in force in India. However, it is intended to support the standards and to highlight to Contractors the areas of concern that shall be addressed in their respective Site Health and Safety Plans in order to establish good health and safety practices.
- 9 This document is intended to supplement the Section on Safety Measures as is contained in the Departments Requirements.
- 10 The obligations and requirements for Health and Safety set out within this document are entirely without prejudice and do not derogate from the Contractor's obligations with respect to the Contract and his statutory obligations with respect to Health and Safety.
- 11 The Contractor is fully responsible for the Health and safety of the Works, his personnel, Associated Contractors/Agencies personnel, the public and all persons directly or indirectly associated with the Works or on or in the vicinity of the Site.
- 12 This Handbook provides relevant information and procedures to assist the Contractor to ensure that his employees and Associated Contractors/Agencies s work within a safety-conscious and safety-regulated environment. Compliance with the procedures set out in this Handbook shall not relieve t he Contractor of any of his Statutory Duties or his responsibilities under the Contract.

## **2 REFERENCES AND DISTRIBUTION OF THIS HANDBOOK**

### ***References***

#### **2.1 The procedures in this Handbook should be read in conjunction with:**

- 1 The Building and Other Construction Workers (Regulation of Employment and Conditions of Service) Act 1996.
- 2 The Factories Act, 1948
- 3 Other Laws of India, Regulations, Rules and Codes of Practice on Safety Health and the Environment that may be applicable.

- 4 The Conditions of Contract in respect of Health and Safety, those apply to the specific Contract under which the Contract is awarded.
- 5 The important Indian Standards and British Standards as applicable to the work of this contract.
- 6 ISO 14001, ISO 45000: and local legislation
- 7 Other Laws of India, Regulations, Rules and Codes of Practice related to Health and Safety that may be applicable.
- 8 Others Government Guidelines for Health and Safety of Construction site

## **2.2 COMPLIANCE**

The construction works should be undertaken in accordance with CPWD SHE Handbook and Management Systems as amended from time to time. All applicable Indian statutory requirements and local regulations should be followed. Given below list is only for reference and contractor is not restricted by the following list in ensuring 100% legal compliance:-

### **2.2.1 Primary statutory regulations**

Contractor should develop thorough understanding about Building and Other Construction Workers (Regulation of Employment and Conditions of Service) Act 1996, Central Rules 1998, the building & other construction workers welfare cess act 1996 and central welfare rules 1998, Building and Other Construction Workers [RE&C] State / Regional latest Rules, Building and Other Construction Workers Welfare Cess latest act and Central Latest Rules, Notification [Central & State] – Collection of Cess, not only to satisfy the Inspectors' perspective but the use of legislation as the strong tool for effective SHE management at construction worksites.

In addition, the construction works should be undertaken in accordance with all applicable legislation and Indian statutory requirements listed below but not limiting to:

- a. Indian Electricity Act 2003 and Rules 1956
- b. National Building Code, 2016
- c. Motor Vehicles Act as amended in 1994 and The Central Motor Vehicles Rules, 1989.
- d. Indian Road Congress Code IRC: SP: 55-2001 'Guidelines on Safety In Road Construction Zones
- e. The Petroleum Act, 1934 and Rules 1976
- f. Gas Cylinder Rules, 2003

- g. Indian Explosives Act. 1884, along with the Explosives substance Act 1908 and the Explosives Rules 1983
- h. The Public Liability Insurance Act 1991 and Rules 1991
- i. Minimum Wages Act, 1948 and Rules 1950
- j. Contract Labour Act, 1970 and Rules 1971
- k. Child Labour (Prohibitions & Regulations) Act, 1986 and Rules 1950
- l. Environment Protection Act, 1986 and Rules 1986
- m. Batteries (Management and handling) Rules # (4. compliance)
- n. Air (Prevention and control of Pollution) Act, 1981
- o. Water (Prevention and Control of Pollution) Act, 1974
- p. The Noise Pollution (Regulation & Control) Rules, 2000
- q. Notification on Control of Noise from Diesel Generator (DG) sets, 2002
- r. Recycled Plastic Usage Rules, 1998
- s. Notification, Central Ground Water Board, Act January 1997
- t. Manufacture, Storage & Import of Hazardous Chemicals Rules, 1989
- u. Solid Waste Management Rules, 2016
- v. Construction and Demolition Waste Management Rules, 2016
- w. The Hazardous Waste (Management & Handling) Rules, 2016
- x. Hazardous Waste Management Rules 1989 (as amended in 1999 and 2016)
- y. Fly ash utilization notification, Sept 1999 as amended in August 2003

### **Workman Compensation Act, 1923 along with allied Rules**

The contractor shall ensure that all his employees / workmen are covered under 'Workmen Compensation Act' and shall pay compensation to his workmen as and when the eventuality for the same arises.

## **2.2.2 International Standards, guidelines and ISO Certification(For big project only)**

The works should be undertaken in accordance with the applicable international guidelines, standards and specifications on SHE and every contractor shall aim to achieve ISO certifications listed below during the currency of the contract

ISO 45000: Occupational Health and Safety Management System. ISO 14001: Environmental Management Systems.

### **Indian Standards;**

IS 3696 (Part 1): 1987 Safety Code for Scaffolds and Ladders, Part 1, Scaffolds

IS 3696 (Part 2): 1991 Safety Code for Scaffolds and Ladders, Part 2, Ladders

IS 13416 (Part 1): 1992 Recommendations for preventive measures against hazards in the workplace, Part 1, falling material hazards protection

IS 13416 (Part 2):1992 Recommendations for preventive measures against hazards in the workplace, Part 2, fall protection

- a. The process of certification shall start immediately after the award of the work and complete within reasonable minimum time. Towards this, the contractor shall undertake the required steps including appointment of ISO consultant from the General Instruction for obtaining the certification on Occupational Health and Safety Management System and Environment Management System.
- b. The contractor is free to choose any ISO consultant of his choice other than the listed one(s), however he shall demonstrate the competency of the consultant and obtain the Department's approval.

## **3. DEFINITION OF TERMS**

The following terms used in this Handbook are defined as follows and shall be construed accordingly.

- a. Safety means the freedom from unacceptable risks of personal harm, i.e. the avoidance of accidents and incidents.
- b. Health means the physical well being of a person and the freedom from any illness caused working conditions.
- c. Hazard means a situation with the potential to cause harm including human injury, damage to

property, plant or equipment, damage to the environment, or economic loss.

- d. Risk means the chance of something adverse happening and its severity. It is a combination of the probability, or frequency, of the occurrence of a defined hazard and the magnitude of the consequences of the occurrence.
- e. Foreseeable means that which is likely or possible.
- f. Site Safety Plan means the contract specific safety plan that the Contractor has produced from his Outline Safety Plan..
- g. Reportable Accident / Incident means an Accident or Incident that is reportable to the Department's Representative. It shall include all fatalities, major injury accidents, dangerous occurrences and all accidents, which result in incapacity for more than Forty Eight hours or more immediately following the accident.
- h. Minor Injury Accident is defined as requiring Medical First Aid.
- i. Major Injury Accident is defined as:
  - Any fracture, other than to the fingers or toes;
  - Any loss of a limb or part of a limb;
  - Dislocation of the shoulder, hip, knee or spine;
  - Loss of sight (whether temporary or permanent); penetrating injury to the eye; or
  - any other injury that: leads to unconsciousness requires resuscitation; requires admittance to hospital for more than 24 hours; or which causes more than 10 days absence from work.

(a) Dangerous Occurrence is defined as:

- Collapse or failure of lifting appliances or hoist or conveyors or other similar;
- Collapse or failure of a crane, derrick, winch, hoist or other appliance used in raising or lowering persons or goods or any part thereof (except the breakage of chain or rope slings), or the overturning of a crane;
- explosion or fire causing damage to the structure of any room or place in which persons are employed, or to any machine or plant, resulting in the complete suspension of ordinary work;
- Electrical short circuit or failure of electrical machinery, plant or apparatus, attended by explosion or fire, causing structural damage involving its stoppage or disuse;

- explosion of a receiver or container used for the storage at a pressure greater than atmospheric pressure of any gas or gases (including air) or any liquid or solid resulting from the compression of gas;
- collapse in whole or part from any cause whatsoever of any roof, wall, floor, structure or foundation forming part of the construction site in which persons are employed;
- Total or partial collapse of any overburden, face, tip or embankment on the construction site;
- The overturning of, or collision with any object by any bulldozer, dumper, excavator, grader, lorry or shovel loader, or any mobile machine used for the handling of any substance on the construction site.

## **4 GENERAL**

### **4.1 Introduction**

- It is the objective of the CPWD to ensure that the Contract is completed on time with quality, within budget, and high standards of safety conforming to Local regulation, Indian and Internal Standards of Health and Safety (i.e. BOCW Act 1996 and amendment 2007, The Air (Prevention and Control of Pollution) Act, 1981/82/83, Environment (Protection) Act, 1986, Rules, 1986, 2016 The Hazardous Waste Management & Handling Rules, 1989; The Petroleum Act, 1934. Labor Act and other related acts.
- This Handbook has system wide application, and therefore not all of the sections will apply to all Contractors. Each Contractor shall develop his own contract specific Site Health and Safety Plan, which will represent his approach to the management of Health and safety on his work, sites under the Contract with CPWD.

CPWD May levy fines against contractors who do not comply with the requirements of this Handbook as per conditions of contract.

### **4.2 Objectives**

- Every Contract should aim at ZAZF (Zero accident & Zero fatality).
- Every contract should aim at 100% legal and other requirement compliance.

### **4.3 Implementation of Policy Objectives**

The following general approach has been adopted by CPWD with a view to achieving the objectives set out above.

- Secure a commitment to safe and healthy working practices by all parties involved in the construction process, including consultants, Contractors, Associated Contractors/Agencies s, workers' unions, and utility providers.
- Develop contract provisions that require Contractors to prepare, implement and monitor safety plans, and ensure that Associated Contractors/Agencies s are also obliged to comply with the same.
- Arrange accident prevention, safety management training for all site staff supervising Contracts.
- Establish Site Safety Management Committees to monitor the implementation of safety plans and keep a record of the Meetings of the Committees.
- Build up a database of accidents and dangerous occurrences, for the purpose of monitoring trends, analysing data, and formulating measures for accident prevention.
- Oversee the safety performance of the Contractors and Associated Contractors/Agencies s to ensure that their duties and responsibilities on health and safety under the Contract, this Handbook, and other relevant Department and Government requirements are fully discharged.

#### **4.4 Responsibility for the Implementations**

The CPMs, PMs and Engineer-in-Charge of the Projects and Contractors Site Management team are responsible for ensuring that the contents of this Handbook continue to meet the requirements and that they are implemented rigorously.

### **5. GENERAL DUTIES OF CONTRACTOR'S AND OTHERS**

#### **5.1 Contractor's Project Manager- SHE responsibilities**

The Project-in-Charge is responsible for the establishment of the Project SHE implementation Plan. This plan shall be according to Engineering Services policies and Client SHE procedures with the assistance of other Manager sand the SHE Manager .Accident prevention procedures will be included in all activities by the application of sound SHE planning. The Project -in-Charge shall set the pace for the project SHE program with the site SHE Manager.

- Approves the project documents related to SHE
- Assume full responsibility for SHE activities on the Project. Ensures project is executed in accordance with SHE management system, contract.
- SHE plan, applicable occupational Safety, Health and Environment regulatory/statutory requirements.

- Shall set SHE objectives and targets, and monitor their implementation.
- Shall ensure that all accidents, occupational illness and environmental incidents are promptly investigated and effective measures are taken to prevent recurrence.
- Shall ensure SHE Committee meetings are organized regularly and chair the SHE committee meeting.
- Shall initiate and take action against the personnel whom are regularly violating SHE norms and creating negative motivation for SHE
- Shall review all Risk Assessment and Emergency Plan for the project activities.
- Shall play a vital role as key person in the event of emergency.
- Ensures compliance to local legislation & company's SHE requirements

## **5.2 Contractor's Planning Manager- SHE responsibilities**

- Shall report to CPM/ Project Manager/Engineer-in-Charge.
- Shall ensure that construction personnel have the relevant competency and experience to execute the work safety.
- Shall ensure that rules and regulation are compiled by all stake holders
- and terms and conditions related to SHE are incorporated in work .
- Shall ensure work procedures contain SHE requirements and hazards are identified, assessed, properly managed and are understood by supervisors /workers.
- Shall visit the work site on routine basis to ensure a high level SHE awareness among the workers is maintained.
- Shall attend weekly SHE meeting and ensures SHE concerns are addressed.
- Shall encourage and support his supervisors to execute safe working practices.
- Shall manage all associated s to ensure that over all SHE compliance is achieved.
- Shall work in close cooperation with the SHE professionals to eliminate and correct all practices and conditions that are deemed to be un safe.
- Shall ensure compliance with all statutory requirements applicable for the project.

### **5.3 Contractor's SHE Manager Responsibilities**

- The Contractor's project SHE manager would be responsible for coordinating and managing all the SHE activities during the project.
- Implement the SHE Plan, Construction Method Statements and other specialist procedures.
- Identify SHE competence requirements for all staff working on the project and ensure delivery of SHE training to personnel within the project team.
- Review and improve method statements for SHE aspects prior to the starting of work.
- Monitor construction activities performance to ensure that identified and appropriate control measures are effective and ensure compliance with the SHE Plan.
- Act as main point of contact between the regulatory authorities and the project on SHE issues.
- In conjunction with the site SHE representatives, overall monitoring of the programme for the SHE works, and provision of status reports as necessary.
- Provision of advice and liaison with the construction teams to ensure that SHE risks are identified and appropriate controls are developed and included within method statements.
- Assistance in the development and delivery of SHE training for site personnel and Associated Contractors/Agencies.
- Liaison with the Department's authorized representatives SHE manager.
- Liaison with the project's public liaison officer.
- Management of the SHE monitoring program, including noise, vibration and dust and review of the routine reports.
- SHE audit of Associated Contractors/Agencies and suppliers.
- Shall act as secretary in SHE committee meeting.

### **5.4 Contractor's SHE Officer / Engineer responsibilities**

- Shall report to SHE Manager.
- Shall inspect emergency service and give report to concerned department / Project manager for compliance of deficiency and for provision of trained and qualified personnel to maintain the emergency services.

- Shall co-ordinate CPWD SHE inspection / walkabout Sessions.
- Shall co-ordinate with all departments, on SHE matters.
- Shall participate in Associated Contractors/Agencies SHE committee meeting.
- Shall conduct initial SHE induction for all workers and visitors.
- Shall carry out daily tour of construction sites with supervisors to coordinate and maintain a good housekeeping and safe practices.
- Shall train and assist supervisors to conduct toolbox meetings.
- Shall ensure that the specified precaution in work permits is complied with.
- Shall conduct SHE meeting on site with attendance by relevant supervisors and work leaders.
- Shall conduct and carry out incident / accident investigation with work supervisors and submit the relevant reports.
- Shall prepare the monthly SHE statistics and submit it to the Management & Client.
- Shall investigate all accidents and recommend the appropriate corrective measure.
- Shall inform all construction Associated Contractors/Agencies about the project SHE requirements and ascertain that Associated Contractors/Agencies complies with the SHE requirement.
- Shall review risk assessment and emergency plan made by the execution team

#### **5.5 Contractor's Construction Supervisor SHE responsibilities**

- Construction Supervisors are directly responsible for the control and activities of craft employees on construction projects. They play key role in the execution and maintenance of an effective jobsite SHE program. The Site Manager and Planning Manager shall establish the standard for a good SHE program. The actual performance of the SHE program is the prime responsibility of Construction Supervisor who has direct contact with the execution team. Construction Supervisors are responsible for wide range of activities. They must plan their SHE activities with the same care and effort as they do other portions of their work program.
- Shall report to the Section In-charge.
- Shall conduct his daily work supervision immediately.

- Shall carry out toolbox meeting to ensure that work crews are made aware of hazards that are to be encountered on the job and adhere to hazard management controls.
- Shall ensure that all work crews are issued with the required safety protective gears and has attended the initial SHE induction.
- Shall monitors and observes that work crews are practicing the recommended safe work and raises standards and SHE awareness.
- Shall carry out daily checks to ensure that hand tools and equipment are in good working condition.
- Shall ensure that each employee under his supervision has received Initial SHE induction training.
- Shall explain all applicable safe practice rules and regulation to all employees under his direct supervision.
- Shall be responsible for housekeeping in his work area and for the use and maintenance of all personal protective devices.
- Shall report immediately all accidents and near miss incidents with or without injury or damage.
- Shall assist the SHE officer in investigation of accidents.
- Shall ensure that all rules and regulation incorporated in SHE Handbook is implemented in his area work.
- Shall report all hazards to SHE department after taking corrective action and compel workers to do so.
- Shall keep risk assessment and job safety analysis at work site and give feedback to work crew working under his control.
- Perform daily observations and report to SHE Manager

#### **5.6 Associated Contractors/Agencies responsibilities**

- Shall attend both client and company SHE induction briefings.
- Shall be fully equipped with required Personal Protective Equipment (PPE), while executing work at site.
- Shall ensure that workers must be supervised and attended by a full time competent supervisor

approved by the construction manager.

- Shall obtain an approval for permit to work before carrying out work in the client's premises.
- Shall take all necessary precautions to ensure that their activities would not affect other fellow worker or, any third party at the work Site.
- Shall take full responsibility for Safety, Health and Environment of his employee during all site operations.
- Shall at his own expense arrange for accident prevention tools & assurances.
- For activities i.e. heavy earth moving equipment operations, LMV & HVM driving, electrical work on high and low tension lines Associated Contractors/Agencies shall employ skilled and competent persons.
- Shall arrange for medical check-up of his entire employee before employment and maintain record.
- Shall inform his employee about the hidden & visible hazards associated with their jobs.
- Shall nominate SHE coordinator out of the working staff & also nominate members for SHE committees.
- Shall ensure that PPE are available all time and shall be used by his employee with no exception.
- Shall arrange for necessary first aid equipment at site.
- Shall ensure that lifting machine, tool and tackle wire ropes, slings, chains, shackles, cranes, pulley blocks shall be of good condition and tested by competent person.
- Shall be responsible to ensure implementation of all legal requirements for workmen under the Local Laws and relevant International Standards

### **5.7 Contractor Employee's SHE responsibilities**

- A team / committee shall be set up by the contractor to execute the SHE requirements and its duties shall include (but not limited to):
- Shall report to Line Supervisor.
- Shall carry out their duties in a safe manner and take care for his Safety and that of other fellow workers who may be affected by his acts.

- Shall work according to the instructions of his supervisors and always comply with the rules and regulation of health, safety and environmental handbook.
- Shall maintain tools and equipment issued to him in a safe operating condition and report defect to his immediate supervisor without delay.
- Shall obtain necessary work permits from his supervisors and abide by his instruction.
- Anticipating SHE issues before they arise and plan for their appropriate mitigation.
- Monitoring the various SHE parameters.
- Inspecting, investigating and auditing the work methodology with respect to SHE mitigation and control.
- Auditing and preparing audit reports, weekly/monthly reports on site SHE conditions

### **5.8 Contractor SHE Policy and plan**

- The Contractor shall formulate a SHE policy and display it at conspicuous places at work sites in Hindi and a local language understood by the majority of construction workers.
- Within 4 weeks of the notification of acceptance of the tender, the Contractor shall submit a detailed and comprehensive Contract specific SHE Plan. The SHE Plan shall include detailed policies, procedures and regulations which, when implemented, will ensure compliance of the contract provisions. The SHE Plan shall include the following but not be restricted to:
  1. A statement of the Contractor's policy, organisation and arrangements for SHE.
  1. The name(s) and experience of person(s) within the Contractor's proposed management who shall be responsible for co-ordinating and monitoring the Contractor's SHE performance;
  2. The number of SHE staff who shall be employed on the Works, their responsibilities, authority and line of communication with the proposed Contractor's agent;
  3. A statement of the Contractor's policy and procedures for identifying and estimating hazards, and the measures for addressing the same;
  4. A list of SHE hazards anticipated for this Contract and sufficient information to demonstrate the Contractor's proposals for achieving effective and efficient health and safety procedures;
  5. A description of the SHE training courses and emergency drills which shall be provided by the Contractor, with an outline of the syllabus to be followed;

6. Details of the safety equipment which shall be provided by the Contractor, including personal protective equipment;
7. A statement of the Contractor's policy and procedures for ensuring that Contractor's Equipment used on the Project Site are maintained in a safe condition and are operated in a safe manner;
8. A statement of the Contractor's policy and procedures for ensuring that Associated Contractors/Agencies s comply with the Contractor's safety plan;
9. A statement of the Contractor's disciplinary procedures with respect to SHE related matters,
10. A statement of the Contractor's procedure for reporting and investigating accidents, dangerous occurrences or occupational illnesses
11. The contractor shall appoint the required SHE personnel as prescribed in BOCWA 1996.
12. And established the safety organization based upon the project value.

### **5.9 SHE Resources**

- Contractor shall describe the SHE resources to be committed to the Project.
- Contractor Management shall support and provide resources to ensure adequate and effective training is provided and documented. Supervisors shall allow adequate time for such training.
- Contractor personnel must be qualified (trained, certified, and experienced) for each project activity involving, but not limited to: demolition, excavations, temporary electrical use, high voltage electrical use, welding, scaffolds, respiratory protection, first aid, fall protection, aerial lifts, forklifts, rigging, and cranes. Contractor must identify all such personnel and provide copies of appropriate documents.
- General Contractor's safety department should have adequate human resources to manage project health and safety. This includes, but is not limited as below:
  1. Office and conference room;
  2. Stationery (computer, projector, material for making signage, digital camera, printer, cabinet etc.,)
  3. Safety training materials (electronic version & hard copy);
  4. National and Local SHE regulations
  5. Inspection tools for safety work (multi meter, noise meter, illuminometer, wind speed meter,

speaker, flash light, tape measure, walky talkie etc.);

6. Medical service resources
7. Personal Protective Equipment (PPE).

Contractor's safety department should have adequate budget to manage project health and safety.

### **5.9.1 Education and experience**

The contractor shall appoint the required SHE personnel as prescribed in BOCWA 1996 & Rules 1998 and establish the safety organisation based upon the project value.

### **5.9.2 Conduct and competency**

The conduct and functioning of the contractor's SHE personnel shall be monitored by CPWD. Any default or deficiency shall attract penalty and or replacement of SHE personnel on immediate basis.

The Contractor shall ensure that all personnel are competent to perform the job assigned to them. In the event that the Contractor is unable to demonstrate the competency of any person whose activities can directly impact on the Works' SHE performance, CPWD shall remove that person from the site without any procedural formalities.

### **5.9.3 Approval from Department**

The name, address, educational qualification, work experience and health condition of each personnel deployed for SHE jobs shall be submitted to CPWD in the format prescribed for the purpose for comments and approval well before the start of the work. Only on approval by CPWD these personnel are authorized to work. In case any of the SHE personnel leaves the contractor the same shall be intimated to CPWD. The contractor shall recruit new personnel and fill up the vacancy.

### **5.9.4 Employment status for the SHE personal**

For all works carried out by the contractor and his Associated Contractors/Agencies s, the responsibility of ensuring the required SHE manpower lies with the main contractor only. The minimum required manpower indicated by the Department includes the Associated Contractors/Agencies s' work also. It shall be the responsibility of the main contractor to provide required SHE manpower for all the works executed by all contractors. Necessary conditions shall be included in all sub-contract documents executed by the main contractor.

### **5.9.5 Reporting of SHE personnel**

All SHE personnel are to report to the Chief SHE Manager who shall report directly to the Chief

Project Manager. CPWD shall monitor adherence to this procedure at all times. In case of non-adherence penalty shall be levied as indicated in the penalty clause.

#### **5.9.6 Inadequate SHE personnel**

In case if the Contractor fail to provide the minimum required manpower as illustrated in General Instruct or fail to fill up vacancies created within 14 days, the same shall be provided by the CPWD at Contractor's cost. Any administrative expenses involved providing the same like paper advertisement or manpower consultant charges, etc. shall also be at the cost of contractor.

#### **5.9.7 Prohibition of performance of the duties**

No SHE personnel shall be required or permitted to do any work which is unconnected to, inconsistent with or detrimental to the performance of the SHE duties for respective category mentioned in General Information

#### **5.9.8 Facility to be provided to SHE Personnel**

The Contractor shall provide all SHE personnel with such facilities, equipment and information that are necessary to enable him to dispatch his duties effectively.

### **6. SAFETY TRAINING**

#### **6.1 Purpose**

It is the learning process that involves the acquisition of knowledge of skills concepts, rules, or changing of attitudes and behaviors to enhance the performance of employees.

SHE training is an important factor in managing SHE on project sites. Contractor, Sub - Contractor and Nominated Sub- Contractor should provide as a minimum the following types of training, but not limited to the following:

1. Induction training
2. Refresher training
3. Tool Box Talk (TBT)
4. Specific Job training
5. First Aid Training
6. Emergency Response Training

## **6.2 Experts / Agencies for SHE services**

Contractors may utilize the services of experts/agencies for the purpose of training, internal audit and any other SHE services with prior approval of the Department.

## **6.3 Induction training**

Contractor shall ensure that Half day SHE induction training should be given to all personnel prior to permitting them to go to the worksite. All personnel shall be issued photo identity cards of size 85mmX55mm duly signed by the authorized representative of the contractor before they are engaged for any activity on the site.

Contractor shall also issue personnel hand SHE hand book in a language known to the worker, which provides information on SHE and emergency procedures that all personnel working on the contract are required to know and the need to follow. Contractor shall ensure that this is distribute and its content introduced to all personnel working at the site.

### **The Induction training should cover at least the following topics -**

- General site SHE rules
- Personal Protective equipment (PPE's)
- Fire fighting
- Emergency procedures
- First Aid
- Specific site hazard and control measures
- MSDS etc.

## **6.4 Refresher training**

Refresher training should be conducted at least every alternate month to ensure that all workers on site are kept up to date with safety requirements on site. It will cover the topics mentioned in safety induction training and as per the requirement of the site.

## **6.5 Tool Box Talk (TBT)**

Each work supervisor shall conduct daily toolbox meetings to discuss health and safety issues before commencement of any activity. Work Supervisors shall lead these meetings. This meeting shall be no longer than 5-15 minutes of duration and items covered at these meetings shall include:

- Hazards and its control applicable to the particular activity
- Safety measures / controls to be adopted during executing the job
- Any important information / happening related to particular activity.
- Safety Oath shall be taken in the end.

All types of training and TBT that is carried out should be properly recorded with their copies being kept on the sites for inspection by the Department's authorized representative. The training record format minimum contains the following things –

- Duration of the training
- Type of training provided
- Training provider
- Topics covered during the training
- Name and signature of the person who attend the training etc.

## **6.6 Specific job training**

Specific training should be provided to persons where risk related to the tasks is high, such as welders, electrician etc. Separate training efforts shall be held throughout the construction period. This training shall be based on the result of SHE inspections, audits, hazardous working conditions, daily SHE observations, etc.

The site SHE Manager and HR Manager shall be responsible for organizing these training sessions. Specific training shall also be conducted for specific activities such as:

- Fall Protection
- Hazardous Materials Communication
- Electrical Safety
- Power Actuated Tools
- Fire Prevention & Protection/ Fire Fighting Equipment's.
- Confined Space Entry
- Work Permit Procedure
- Excavation Work

- Lifting Operations
- Material handling
- Working with chemicals.
- Blasting if any.

Such training shall be conducted by the site SHE Manager and shall be carried out prior to the use or implementation of an activity which requires same.

## **6.7 First Aid Training**

Training on first aid shall be organized for all site staffs and workers by qualified doctor / competent authority. The names of the trained first aiders shall be displayed at all prominent work locations.

## **6.8 Emergency Response Training**

### **6.8.1 Drills and exercises**

Emergency drill shall be conducted periodically once in every month. Emergency drills and exercises shall be carried out to test preparedness of emergency arrangements. Emergency evacuation drill shall be organized on likely incidental scenario. Emergency evacuation drill register shall be maintained containing information for type of drill, location of drill, participants and observations.

- Shifting of injured personnel from work location to First Aid Centre / hospital.
- Fire drills
- Traffic Jam
- Other emergency situations i.e. Road Accident etc.

## **6.9 SHE Meetings**

- The Monthly SHE Committee Meeting shall be chaired by the Project Manager. Associated Contractors/Agencies SHE Representatives and Construction supervisor shall be scheduled to attend the meetings. Invitations to sit on the committee shall be extended to Client representatives.
  - The responsibilities of this Committee shall include the following:
  - Overall objective analysis of the site SHE activities.

- Good Safety practices being adopted/ to be adopted.
- Deficiencies found during safety inspection / audits and measures to be taken to improve the same.
- Incidents/accidents or near misses that have occurred and review of Investigation and recommendation.
- Hazard observed and corrective action.
- Identification of Unsafe act.

The SHE meeting shall be recorded and copy of minutes of meeting shall be forwarded to all concerned for action and implementation. In this meeting the suggestions of the attending members shall be reviewed on their past experience and shall be recorded for action and implementation.

### **6.10 Supervisory Staff Meeting**

Supervisory staff meeting shall be held on a MONTHLY basis. This meeting shall be conducted by the site SHE Manager and chaired by Project Manager. The purpose of this meeting is to discuss the past month activities and next month's activities related to SHE.

**Note: - Training registers will be maintained for all training courses delivered.**

## **7. SAFETY PROMOTION & PENALTY**

Safety Promotion each sites in the interests of promoting safety awareness amongst the workforce shall devise and implement practical Safety Promotion schemes. The objective of these schemes should be to recognize and reward individuals who continually Endeavour to work in a safe manner.

Suggestions for such promotions may include such items as the issue of the following as rewards to individuals for good safety performance.

The Following categories should be consider for the awards as per the scheme

- For every safe million man hour working without any reportable incidents
- Zero fatality contract
- 100% adherence to voluntary reporting of all accident throughout the currency of contract
- Safest project team of the year
- Best SHE team of the year

- Safest contractor of the year.

The Department aims to build an image of one of the best safety conscious organizations in their project and operation. In case of any accident, it not only results in illness, injury, loss of life and/or property damage but also damages the reputation of the organization. Most of the accidents are avoidable and caused preliminary due to contractors' negligence. Hence the Department shall recover the cost of damages from the contractors for every reportable incident (fatality / injury).

In many cases the voluntary compliance to the condition of contract on SHE and project SHE Handbook is not observed. Hence the Department has been forced to establish safety-enforcing activities. The cost of establishing such activities is to be recovered from contractors for all observed safety violations at sites. The following table indicates the Safety, Health and Environment violation (unsafe act / unsafe condition) and charges to be recovered from contractors.

Note: The money deducted/recovered is to be used for enhancing the SHE management and betterment of working conditions for the workforce at site/worker accommodations only. This should not be seen/treated as a means for earning money.

Tentative Charges to be recovered from contractor for unsafe act or condition

Schedule of Penalty to be included in schedule F as decided by Project incharge.

SL. NO.	TOPIC	UNSAFE ACT/UNSAFE CONDITION	DEDUCTIBLE AMOUNT
1.	SHE Policy & plan	a) If fails to formulate the SHE policy and fails to display the same at the work place in local language and in English/Hindi which is understood by the majority of construction worker. b) Inadequate coverage, not signed c) Not displayed at prominent locations	Rs.1,000 per single violation, compounded to a maximum of Rs.5,000 at any single Instance.
		ii) SHE plan: a) Not as per Departments' content and coverage b) Delay in submission c) if SHE plan is Not updated as per Department's Instruction (if insufficient) within seven days. d) Copies not provided to all required supervisors / engineers	Rs.1,00,0 per single violation, compounded to a maximum of Rs.2,00,0 at any single instance.

2.	SHE Organisation	<p>i) Not complying to the minimum manpower requirements as mentioned in General Instruction</p> <p>ii) Not filling up the vacancies created due to SHE personnel leaving the contractor within 14 days.</p> <p>iii) SHE organisation not provided with required audio-visual and other equipment as per general instruction</p> <p>iv) Employing through outsourcing agencies and SHE personal are not in the payroll of the main contractor</p> <p>v) disobedience/ improper conduct of any SHE personnel</p> <p>vi) chief SHE manager not reporting directly to CPM of contractor</p>	<p>i) Rs.1,000 per month for first month and Rs.2,00,0 for subsequent months</p> <p>ii) Rs.50,00 per month for first month and Rs.1,00,00 for iii) subsequent months For items iii), iv), v) and vi)</p> <p>Rs.50,00 for first violation and Rs.1,00,00 for subsequent violations</p>
3.	SHE Committee	<p>Failed to formulate or conduct SHE Committee meeting for any month Contractor and Associated Contractors/Agencies representatives not attending SHE Committee meetings</p> <p>Failed to conduct Site inspection before conducting SHE Committee meeting</p> <p>Failed to send SHE Committee Meeting minutes or Agenda to Department in time</p> <p>If minimum 21 days not maintained between two SHE committee meeting.</p> <p>Minutes of meeting shall be prepared as per the format provided and sent to all members (Format)</p>	<p>i) Rs.1,00,0 for the first violation and Rs.5,00,0 for the subsequent violations</p> <p>ii) Rs.5,00 to the contractor of the member who had not attended the meeting for first violation and Rs.25,00 for Subsequent violations.</p> <p>For item iii), iv), v) and vi)</p> <p>Rs.25,00 for first violation and Rs.50,00 for subsequent violations</p>
4.	ID Cards	<p>If Contractor fails to ensure that all personnel working at site receives the induction training on the first day.</p> <p>If all personnel not received the photo ID card of size 85mm X 55mm duly signed by the authorize representative of contractor before engaging them into work.</p>	<p>Rs.1,00,0 for first violation and Rs.2,00,0 for subsequent violations</p>

5.	SHE Training	<p>Not complying to the requirements as mentioned in conditions of contract on SHE and project SHE Handbook with regard to:</p> <p>a) Induction training not given</p> <p>b) Supervisor/engineer/manager training not conducted</p> <p>c) Refresher training for workers not conducted at the interval of six months.</p> <p>d) Tool-box talk not conducted.</p> <p>e) Skill development training not conducted such as – Height work safety, scaffolding safety, crane safety, welding safety, electrical safety, traffic safety.</p> <p>f) Daily Safety Oath not conducted as per clause 9.10(required).</p> <p>f) Top management behaviour based SHE training conducted</p>	<p>For item 1 a) to g) Rs.500 for first violation on and Rs.1,000 for subsequent violations</p>
6.	SHE Inspection	<p>i) If the contractor not involved and administer a system of not conducting SHE inspections and other risk management analysis on a periodical basis.</p> <p>ii) If all inspection record and reports are not maintained for the purpose of audit.</p>	<p>Rs.50,00 for first violation and Rs.1,00,00 for subsequent violation</p>
7.	SHE audit	<p>Internal Audit: MARS and Electrical Safety not conducted as per SHE Plan. Report not sent to Department action not taken for any month</p>	<p>Rs.50,00for first violation and Rs.1,00,00 for Subsequent violations.</p>
8.	SHE Communication	<p>Important days to be observed for SHE awareness as furnished by Department not observed</p> <p>Posters as furnished by Department not printed and displayed</p>	<p>Rs.10,00 for first violation and Rs.50,00 for subsequent violations</p> <p>2,00,00 per contract</p>

9.	SHE Submittals	<p>Contractor SHE management should send the following reports.</p> <p>SHE inspection report SHE audit report Monthly audit rating score report External SHE audit ( Once in six month) Noise monitoring report.</p> <p>If not reported to Department about manpower employed by contractor or Associated Contractors/Agencies within two hours of starting shift.</p> <p>Contractor shall submit the monthly SHE report including:- Monthly man hour detail Monthly accident incident detail SHE committee details Monthly SHE training details SHE inspection details. SHE internal inspection details Air quality /noise monitoring details Toolbox talk details PPE details for stock available/issued to workmen Electrical inspection details Monthly LUX meter study details Housekeeping Barricade and maintenance details No of critical excavations Health and welfare activities Safety walk conducted by contractor project manager in the month SHE activity planned for next month.</p>	<p>For item i) Rs.50,00 for first violation and Rs.1,00,00 for subsequent violations</p> <p>For item ii) and iii) Rs.1,00,0 for first violation and Rs.2,00,00 for subsequent violations</p>
10.	Injury and incidence reporting	<p>(i) Fatal accidents (ii) Injury accident (iii) Abnormal delay in reporting accidents or willful suppression of information about any accidents / dangerous occurrence.</p> <p>(iv) Delay in informing about any Accidents / dangerous incidents.</p> <p>(v) Departments independent incident investigation take place if any fatal/dangerous occurrence and contractor shall ensure to extend his staff to necessary co-operation and testify about the accident. Contractor shall take every effort to preserve the scene of accident till the process.</p>	<p>Rs.5,00,000 for first fatality and Rs.10,00,000 for every subsequent fatality.</p> <p>Rs.1,00,000 for first grievously injured person and Rs.2,00,000 for every subsequent grievously injured person (Grievous Injury as defined by Workmen Compensation Act)</p> <p>Rs.1,00,000 for first violation and Rs.2,00,000 for subsequent violations</p> <p>For items iv) and v) Rs.50,000 for first violation and Rs.1,00,000 for subsequent violations</p>

11.	Emergency preparedness Plan	<p>Non compliance to prepare ERP where it applicable, injury, sickness, evacuation, fire, chemical spillage, severe weather and rescue for all work sites as a part of contract</p> <p>Contractor shall ensure that an ERP is prepared to deal with emergencies arising out of.</p> <p>Fire and explosion Collapse of building, shed or structure etc.</p> <p>Collapse of lifting appliances and structure etc.</p> <p>Gas leakage or spillage of dangerous goods or chemicals</p> <p>Bomb threatening , criminal or terrorist attack</p> <p>Drowning of workers</p> <p>Landslides getting workers buried floods, earthquake, storms and other natural calamities</p> <p>Arrangement shall be made for emergency medical treatment and evacuation of victim</p> <p>Contractor shall require tying up with the hospital and fire stations located in the neighbourhood.</p> <p>Emergency vehicle kept on standby duty during the working hours for the purpose</p> <p>Contractor to keep the Local Law and order , authorize informed and seek urgent help, prompt communication to IKEA.</p> <p>Telephonically and followed by a written report shall be made by the contractor.</p>	Rs.1,00,00 for non-compliance of any of the clauses
-----	-----------------------------	--	---

12.	Housekeeping	<p>Housekeeping maintenance register not properly maintained up to date</p> <p>Surrounding areas of drinking water tanks / taps not hygienically cleaned / maintained</p> <p>Office, stores, toilet / urinals not properly cleaned and maintained.</p> <p>Required dustbins at appropriate places not provided / not cleaned.</p> <p>Stairways, gangways, passageways blocked.</p> <p>Lumber with protruding nails left. Openings unprotected Excavated earth not removed within a reasonable time.</p> <p>Truck carrying excavated earth not covered / tyres not cleaned.</p> <p>Vehicles / equipment's parked / placed on roads obstructing free flow of traffic</p> <p>Unused surplus cables / steel scraps lying scattered</p> <p>Wooden scraps, empty wooden cable drums lying scattered</p> <p>Water stagnation leading to mosquito breeding</p>	<p>Rs.10,00 per single violation Compounded to a maximum of Rs.1,00,00 at any single instance</p>
13.	Working at Height/Ladders and Scaffolds	<p>Not using or anchoring Safety Belt Not using Safety Net Absence of life line or anchorage point to anchor safety belt</p> <p>If fails to provide Requirements for all working platform s</p> <p>Using Bamboo ladders Painting of ladders Improper usage (less than 1m extension above landing point, not maintaining 1:4 ratio) Aluminium ladders without base rubber bush</p>	<p>Rs.10,00 per single violation Compounded to a maximum of Rs.1,00,00 at any single instance</p>

		<p>Usage of broken / weak ladders  Usage of re-bar welded ladders  Improper guardrail, toe board, barriers and other means of collective protection  Improper working platform  Working at unprotected fragile surface  Working at unprotected edges</p>	
14.	<p>Lifting  Appliances and gears.</p>	<p>Non availability of fitness certificate.</p> <p>Documents not displayed on the machine or not available with the operator. fitness certificate issued by competent person The Department approval letter, the operator photo, manufacturer's load chart, and competency certificate</p> <p>Maximum Safe Working Load not written on the machine</p> <p>If not maintained the register of record for identification of all tools and tackles, its date of purchase, safe work load, competent person date of examination etc.</p> <p>Test and periodical examination of lifting appliances and gears</p> <p>Automatic safe load indicator not provided or not in working.</p> <p>Age of the operator less than 21 years or without any license and non-compliance of qualification of operators of lifting appliances and of signaler etc.</p> <p>Non-compliance to general requirements of appliances</p> <p>Non-compliance of any of the items mentioned regarding rigging requirements, no close working near any live overhead power line is permitted without the operation of strict permit to work.</p>	<p>Rs.50,00 per single violation  Compounded to a  maximum of Rs.5,00,00 at any single instance</p>

		<p>Failure to submit method statement in case of all critical lifting  Person riding on crane.  Creating more noise and smoke  Absence of portable fire extinguisher in driver cabin</p> <p>Fail to guard hoist platform</p> <p>No fencing of hoist rope movement area</p> <p>Hoist platform not in the horizontal position</p> <p>Non-compliance to employ qualified and competent electrical personnel.</p> <p>As the small capacity generators creates more noise and safety hazard, No small capacity diesel generators shall be allowed for whatsoever the type of job to be executed under this contract.</p>	
15.	Site Electrical safety	<p>Non-compliance to submit the electrical single line diagram, schematic diagram and the details of the equipment for all temporary electrical installation and these diagram together with the temporary electrical equipment shall be submitted to the Department's for necessary approval.</p> <p>Non-compliance to provide the Electrical protecting circuits, cables in good condition and as per BS-6346,7375,6708, and the contractor shall insure plugs, sockets-outlets, couplers available in the construction site as " splash proof" type. Should of IP 44 an accordance with BS EN60529</p> <p>If connections found in unsafe manner  Work on or near live conductors  Exposed electric lines (fermentative damage) and circuits in the workplace.</p>	<p>Rs.10,00 per single violation  Compounded to a maximum of Rs.1,00,00 at any single instance</p>

		<p>Inserting of bare wires into the socket Improper grounding for the electrical appliances</p> <p>Electrical cables running on the ground</p>	
16.	Hand tools and Power tools	Non-compliance of maintaining and inspection of Hand tools and power tools	Rs.10,00 per single violation Compounded to a maximum of Rs.1,00,00 at any single instance
17.	Gas Cutting	<p>Wrong colour coding of cylinder. Cylinders not stored in upright position. Flash back arrester, non-return valve and regulator not present or not in working condition.</p> <p>Fail to put cylinders in a cylinder trolley.</p> <p>Damaged hose.</p> <p>Using domestic LPG cylinders</p> <p>Fail to store cylinder 6.6m away from fire prone materials</p> <p>Fail to use hose clamps</p> <p>Fire extinguisher not placed in the vicinity during operation</p>	Rs.10,00 per single violation Compounded to a maximum of Rs.50,00 at any single instance
18.	Welding	<p>Voltmeter and Ammeter not working Improper grounding and return path. Damaged welding cable Bare openings in the cable.</p> <p>Non-availability of separate switch in the transformer</p> <p>Non-availability of main switch control to switch off power to the welding unit.</p> <p>Usage of reinforcement rod as return conductor</p> <p>Damaged holder</p> <p>Fire extinguisher not placed in the vicinity during operation</p>	Rs.10,00 per single violation Compounded to a maximum of Rs.50,00 at any single instance

19.	Fire precaution	<p>Smoking and open flames in fire prone area</p> <p>Using more than 24V portable electrical appliances in the fire prone area</p> <p>Not proper ventilation in cylinder storage area.</p> <p>Absence of fire extinguishers</p> <p>Fire extinguishers not refilled once in a year.</p> <p>Fire extinguisher placed in a not easily accessible location</p>	<p>Rs.5,000 per single violation Compounded to a maximum of Rs.25,000 at any single Instance.</p>
20.	Work permit system	<p>Non-compliance to take permits for the following</p> <p>Confined space entry</p> <p>Work in close proximity to overhead power lines and telecommunication cables</p> <p>Hot work Excavation Heavy moving machinery Working on electrical equipment Work with radioactive isotopes Heavy lifting operations and lifting operations closer to live power lines</p> <p>Non-compliance of no close working to any live overhead power line is permitted without the operation of a strict permit to work.</p>	<p>For item I) and ii) Rs.50,00 per first violation and Rs.1,00,00 for subsequent violations</p>

21.	Traffic management	<p>Non-compliance to take proper precautions, wherever operations undertaken are likely to interfere with public traffic, specific traffic management plans shall be drawn up and implemented by the contractor in consultation with the approval of local police authorize and /or the concerned metropolitan/civil authority as the case may be.</p> <p>Non-compliance to put warning signs</p> <p>Non-compliance to put cones and cylinders where necessary (500,750,amd 1000mm high and 300,500 diameter)</p> <p>Non-compliance to Drums for channelizing or warning devise due to high visibility and appearance of being formidable object(800 to 1000 mm high and 500 mm in diameter) and therefor command the respect of drivers</p> <p>Non-compliance to provision of tow away vehicle</p> <p>Non-compliance to cleaning the rods Barricades</p> <p>Not Cleaned Not in alignment Not numbered Not painted Red lights / reflectors not working Damages not repaired Not secured properly</p> <p>Barricade inspector not employed Protruding parts / portions repaired Barricades maintaining register not properly maintained up to date</p> <p>Contractor vehicles over loading of vehicles unfit driver or operator Unlicensed vehicle Absence of traffic marshal Absence of reversing alarm Absence of fog light (at winter). Power/ Hand breaks not in working condition</p>	<p>Rs.1,00,00 per first violation and Rs.2,00,00 for subsequent violations</p> <p>Rs.25,00 per single violation Compounded to a maximum of Rs.1,00,00 at any single instance</p> <p>Rs.25,00 per single violation Compounded to a maximum of Rs.1,00,00 at any single instance</p>
-----	--------------------	--	--

22.	Personal protective equipment's	<p>Not having</p> <p>Not wearing (or) using and kept it elsewhere</p> <p>Using damaged one Using wrong type Using wrong colour helmet or helmet without logo as decided by Engineer in Charge</p> <p>Using for other operation (e.g. Using safety helmet for storing materials or carrying water from one place to other)</p> <p>Not conforming to BIS standard</p> <p>Contractor shall not pay any cash amount lieu of PPE to the worker/sub- contractor and expect them to buy and use during work. Contractor shall maintain minimum of 10% spare PPE's and safety appliances and properly record and shoe to the Department during the inspection</p>	<p>From item i) to vi).</p> <p>Rs.200 per single violation</p> <p>For item vii)</p> <p>Rs.10,00 for first violation and Rs.50,00 for subsequent violations</p> <p>For item viii)</p> <p>Rs.50,00 for first violation and Rs.1,00,00 for subsequent violations</p>
23.	Occupational health	<p>Fail to conduct medical examination to worker</p> <p>Absence of ambulance van and room</p> <p>Worker not having ID cards</p> <p>Inadequate number of toilets</p> <p>Toilet not cleaned properly</p> <p>Absence of water facility for toilet and washing place</p> <p>Toilet placed more than 500 m from the work place</p> <p>Absence of drinking water</p> <p>Absence of first aid person in work site</p> <p>Absence of inadequacy of first aid box.</p> <p>Misuse of first-aid box</p> <p>First aid box not satisfy the minimum Indian standard</p> <p>Smoking inside the construction site</p> <p>Drink and drive or work</p> <p>Excessive noise and vibration</p> <p>Canteen not provided</p>	<p>Rs.10,00 per single violation Compounded to a maximum of Rs.1,00,00 at any single instance</p>

		<p>Food stuff not served on no loss no profit basis</p> <p>Creech not provided</p> <p>Accommodation not provided as per BOCW Act.</p> <p>Fumigation/insecticides not sprayed to prevent mosquito breeding</p> <p>Non-compliance of providing proper ventilation and illumination.</p>	
24.	Labour Welfare measures	<p>Non adherence of Labour welfare provisions of BOCW Act</p> <p>Fail to register establishment and display the registration certificate at workplace</p> <p>Absence of workers register and records</p> <p>Absence of muster roll and wages register</p> <p>Fail to display an abstract of BOCW Act.</p>	<p>Rs.10,00 per single violation</p> <p>Compounded to a maximum of Rs.50,00 at any single instance</p>
25.	Environmental management	<p>Tire wash facility not provided.</p> <p>Spillage from vehicles not arrest</p> <p>Air monitoring not practiced</p> <p>Noise monitoring not practiced</p> <p>The value of air monitoring and noise monitoring not within acceptable limits</p> <p>Dust control measures at sites not practiced</p> <p>Improper disposal of debris/residues</p>	<p>Rs. 10,00 per single violation</p> <p>compounded to a maximum of Rs.50,00 at any single instance.</p>

Without limiting to the unsafe acts and or conditions mentioned above in CPWD shall have the right to deduct charges for any other unsafe act and or condition depending upon the gravity of the situation on a case-to-case basis.

### 7.1 Stoppage of work

CPWD shall have the right to stop the work at his sole discretion, if in his opinion the work is being carried out in such a way that it may cause accidents and endanger the safety of the persons and / or property, and / or equipment. In such cases, the contractor shall be informed in writing about the nature of hazards and possible injury / accident.

The Contractor shall not proceed with the work until he has complied with each direction to the satisfaction of CPWD.

The Contractor shall not be entitled for any damages / compensation for stoppage of work, due to safety reasons and the period of such stoppage of work shall not be taken as an extension of

time for Completion of the Facilities and will not be the ground for waiver of levy of liquidated damages.

## **8. INDUCTION TO THE EMPLOYEES AND VISITORS**

### **8.1 Purpose**

The purpose of the SHE Induction procedure is to ensure all CPWD staff and visitors are aware of Management's commitment towards health and safety and compliance. The SHE induction will alert all persons of the potential hazards on site and in the office.

## **9. EMERGENCY PREPAREDNESS AND RESPONSE**

Emergency Planning is required to ensure a structured response to any emergency on the site. Site Emergency Plan includes identification of emergencies, description of the responsibilities and functions of the key members of the Site emergency response team, with and without support from local authorities, local fire brigade and hospitals.

The purpose is to establish systems and procedures for dealing with emergency situations including contingency arrangements for business recovery.

Contractors shall require to tie-up with the hospitals and fire stations located in the neighbourhood for attending to the casualties promptly and emergency vehicle kept on standby duty during the working hours for the purpose.

Contractor shall conduct an onsite emergency mock drill once in every month for all his workers and his Associated Contractors/Agencies workers.

It shall be the responsibility of the contractor to keep the Local Law & Order Authorities informed and seek urgent help, as the case may be, so as to mitigate the consequences of an emergency. Prompt communication to IKEA, telephonically initially and followed by a written report, shall be made by the Contractor.

### **9.1 Emergency Conditions**

Every Contractor should prepare an Emergency Preparedness Plan for each of his project sites. These plans identify the foreseeable emergencies that may arise during the project activities. Examples of activities that will be considered as an emergency situation on project site includes but not necessarily be limited to –

- Accident
- Fire

- Electrical Cable rupture
- Structure collapse/soil collapse during excavation
- Natural calamities
- Security alerts
- Vehicle topple
- Leakage of dangerous materials and chemicals
- Major Injury / Fatality at the site etc.

#### **9.1.1 The Emergency response plan at least contains the following information:**

- The name, location and phone number of the Emergency Co-coordinator
- Designated Personnel with locations and phone numbers
- Details of the Emergency Response Team with locations and phone numbers
- Functions of the individual member in the Emergency response Team
- The location of the emergency exits and the means of Escape
- Communication flow with the Emergency Services like Police, Fire Services, Ambulance etc.
- First-Aid Facilities
- Evacuation routes
- Location of Assembly points etc.

#### **9.1.2 Emergency Response Leadership Structure**

Please refer to the Emergency action plan and disaster management plan.

### **9.2 FIRST AID**

Qualified First aiders and First aid facilities shall be at each workplace. Every injury shall be reported and treated. First aiders shall be in possession of a valid first aid certificate issued by a competent authority. The first aid facility shall be in accordance with applicable Laws. Alternatively the agreements shall be made with nearby hospital for treatment of injured or persons suffering from sickness. A first aid log will be maintained for injuries and sickness. Agreement should have provision to provide ambulance service on call basis or for deputing at site in case of critical activity on standby during work hours.

### **9.3 MEDICAL CARE**

A Clinic shall be set up & a Qualified Doctor should be appointed wherein 500 or more construction workers are employed at site along with the arrangement suggested in BOCW Act and related schedules.

A Male Nurse shall be responsible for upkeep and maintenance of the Site Clinic and he shall always be available in case of any emergency.

### **9.4 AMBULANCE VAN (Only for remote sites ) or for Big projects**

The Contractor shall ensure at construction site that an ambulance van for transportation of serious cases of accident or sickness of building workers to the hospital promptly and such ambulance van is maintained in good condition and is equipped with standard facilities specified in schedule V, BOCWA.

### **9.5 TIE UP WITH NEARBY HOSPITAL**

During construction, the Contractor shall Tie-Up with nearby hospital to arrange medical treatment in serious cases of accident or sickness of the building worker promptly.

## **10. HAZARDS AND RISK MANAGEMENT**

### **Purpose**

The purpose of a risk assessment is to allow a safe method of work to be developed which will avoid or minimise the risk to the health ensure, safety and welfare of employees and others affected by the work activities, as well as considering potential impacts to the environment. Those staff members assessing these

risks should be competent, as determined by experience and relevant qualifications, to be able to identify hazards and aspects and make a judgement of severity and likelihood of SHE risks and I mpacts, as well as determining the most suitable method of risk management, based on legislative guidelines and best practice.

### **Scope**

This procedure applies to project site. Aspect identification & Risk assessments shall be limited at site to the hazards relating to any employee working inside the project site.

### **Responsibilities**

Project Manager/Construction Manager/Site In-charge or his nominated representative or any employee who is competent to undertake risk assessments (e.g. SHE Manager) on behalf of Project

Manager/Construction Manager/Site In-charge.

## 10.1 Procedure

### 10.1.1 Health & Safety Risk Assessment

The Risk Assessment and Environmental Impact Assessment shall at a minimum:

- i. Ensure risk assessment for all activities that could cause a major hazards to safety of human being, or adverse impact to the environment .
- ii. be based on consultation with all related employees;
- iii. address routine and non-routine activities of all persons having access to the workplace;
- iv. address supply chain and contractor undertakings;
- v. address human behaviour;
- vi. identify hazards at joining outside the workplace capable of adversely affecting the environment and / or health and safety of employees;
- vii. Address potential risk to persons working inside and outside of premises.
- viii. address plant, machinery, equipment, substances and materials at the workplace;
- ix. address the design of work areas, processes, work organisation and operating procedures;
- x. ensure documentation, recording and communication of the results of the risk management procedure; and
- xi. Incorporate recognised steps of risk management.

Step 1 – You need to identify hazards (something with the potential to cause harm to someone, or cause damage to property).

Step 2 – Decide who is going to be harmed and how

Step 3 – Evaluate the risk (using Likelihood & Severity/Consequence scale 1-5 for each multiply together to obtain risk rating).

Step 4 – Introduce control measures to prevent harm occurring, record your findings and communicate to all employees.

Step 5 – Review your risk assessment as needed i.e. work method changes.

(A) Note: Risk assessments shall be prepared within 3 months of mobilisation at site and at every six months thereafter or as decided by the Engineer-in-Charge Persons at Risk (Affected Groups)

<b>A:</b> Employees involved with task / activity	<b>B:</b> Employees not involved in task / activity	<b>C:</b> Contractors / Associated Contractors/Agencies s
<b>D:</b> Office / Project Visitors	<b>E:</b> Members of the Public	<b>F:</b> Young Persons/Pregnant Woman

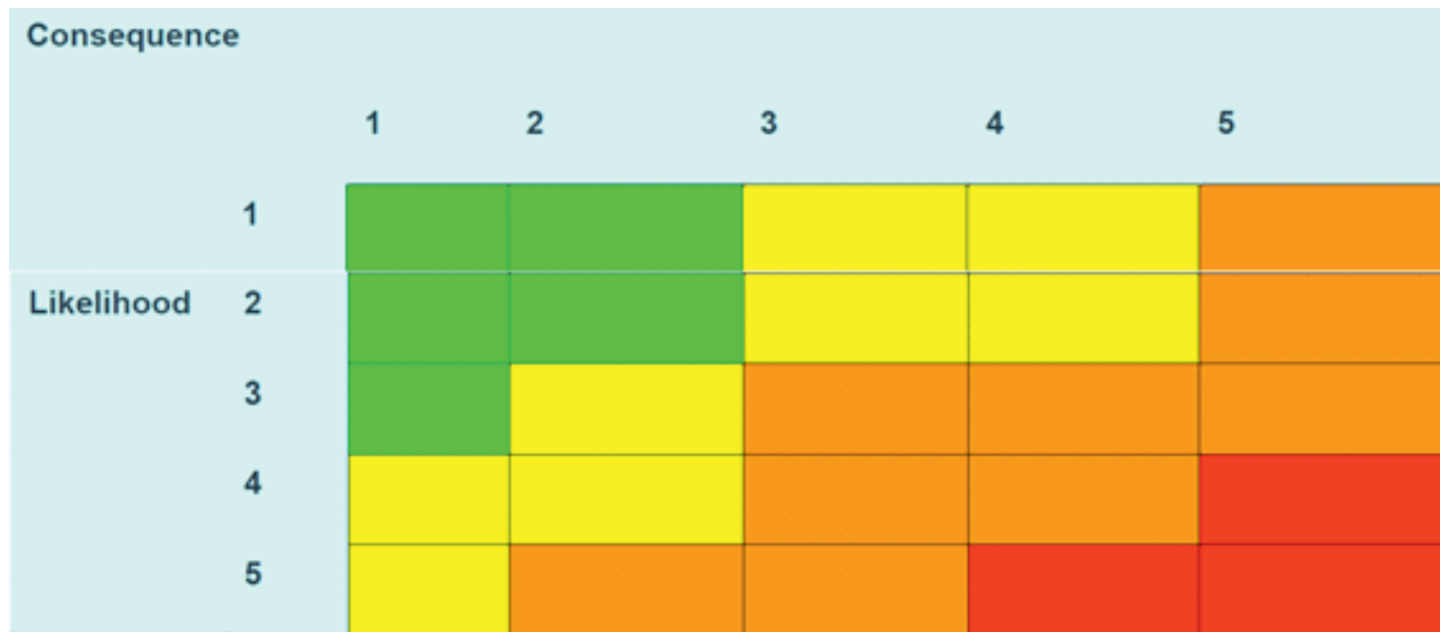

	<b>Extreme risk</b>	<b>Activity should not proceed in current form.</b>  Try to eliminate the hazard or decrease the risk by providing less risky hazard.
	<b>High Risk</b>	<b>Activity should be modified to include remedial planning and action including improvement programs.</b>
	<b>Moderate risk</b>	<b>Activity can operate subject to management and/or modification. Operational control procedures may be developed to control the hazard/Aspect.</b>
	<b>Low Risk</b>	<b>No action required, unless escalation of risk is possible.</b>

When determining control measures, or changes to existing control measures, consideration shall be given to reducing the risks according to the following hierarchy.

<b>Elimination</b>	Eliminate the risk by removing the hazard.
<b>Substitution</b>	Substitute less hazardous material, equipment, processes or substances.
<b>Engineering controls / isolation –for plant and equipment</b>	Make structural changes to the work environment, work systems, tools or equipment. Use mechanical aids or Handbook handling devices. Enclose or isolate the hazard through the use of guards or remote handling techniques. Provide local or general exhaust ventilation <b>or any other appropriate measure.</b>
<b>Administrative Controls</b>	Appropriate administrative procedures such as policies, guidelines, standard operating procedures (SOPs), registers, work permits, safety signage, job rotation, job timing, routine maintenance and housekeeping, Provide training on Hazards and correct.
<b>Personal protective equipment (PPE) –</b>	This is the last resort if the above measures are not practicable. Provide correctly fitted and properly maintained personal protective equipment (PPE), and /or protective clothing and training in its use.

### 10.3 Five steps to identify aspects & evaluate impacts:

Step 1 - Look for the environmental aspects in your work / site environment that are related to the activities, products & services delivered by the contractor at site.

Step 2 - Identify those aspects which can be classified as 'Direct' (which can be controlled by CPWD or "indirect' (where CPWD can only influence the control). Establish whether the occurrence of the activity, product or service, exists in Normal, Abnormal or emergency conditions.

Step 3 - Evaluate impacts arising and decide whether the existing assumptions and requirements are satisfactory, or whether more efforts should be made to eliminate or reduce the impact. Suggest changes if required.

Step 4 - Record the findings.

Step 5 - Review your assessment and revise if necessary.

Note: Risk assessments shall be prepared within 3 months of mobilisation at site and at every six months thereafter or as decided by the Engineer-in-Charge .

Environmental Likelihood	Environmental Consequence	Rating
Continuous or will happen frequently	<ul style="list-style-type: none"> <li>• Long-term and significant change in population (eg. Eradication of endangered species) or habitat with negative impact on ecosystem function.</li> <li>• Widespread destruction to a significant area of land, rare flora and fauna and/or ground water resource.</li> <li>• Catastrophic environmental impact due to uncontained release, fire or explosion with detrimental effects.</li> <li>• Outside assistance required.</li> <li>• Extensive chronic discharge of persistent hazardous pollutant.</li> <li>• Results in the generation of significant quantities of intractable wastes.</li> </ul>	5
12-20 times a year; happens more than twice in a month	<ul style="list-style-type: none"> <li>• Continuous and serious damage by erosion or to flora or fauna.</li> <li>• Major disruption to, or frequent death of, rare flora and fauna.</li> <li>• Major destruction of significant habitat.</li> <li>• Major environmental impact due to uncontained release, fire or explosion with detrimental effects.</li> <li>• Outside assistance required.</li> </ul>	4
5-12 times a year, happens monthly or more	<ul style="list-style-type: none"> <li>• Significant changes in flora/fauna populations and habitats</li> <li>• Disruption to, or some death of, rare flora/fauna, but not resulting in eradication of endangered species.</li> <li>• Non persistent but possibly widespread damage to land that can be remediated without long term loss.</li> <li>• Creation of noise, odour, dust, other controlled/uncontrolled air emissions, greenhouse gases, vibration, and visual impact at significant nuisance levels.</li> <li>• Results in generation of significant quantities of hazardous wastes.</li> </ul>	3
1-2 times a year	<ul style="list-style-type: none"> <li>• Minor impacts on flora/fauna and habitats, but no negative impact to eco system functions.</li> <li>• Limited damage to land area of no significant value.</li> <li>• Temporary damage or disruption (less than 1 month) to flora/fauna and land use.</li> <li>• No significant impact on water resources.</li> <li>• Minor environmental impact due to contained release of pollutant (including odour, dust and noise), fire or explosion with no detrimental effects.</li> <li>• Significant use of water, fuels and energy and other natural resources.</li> </ul>	2
More than once a year	<ul style="list-style-type: none"> <li>• Insignificant environmental impact. Occasional damage by erosion, or of flora and fauna. some disruption to flora and fauna</li> <li>• Temporary nuisance from noise, dust, other air emissions, greenhouse gases, vibration, visual impact.</li> <li>• Minor use of water fuels and energy and other natural resources.</li> <li>• Results in the generation of significant non -hazardous wastes.</li> </ul>	1

Significance Criteria: 1. All aspect rated as High Rate of (5) & Medium Rate of (3 & 4) shall be considered significant aspect. Irrespective of overall rating, consumption of water, electricity and paper are considered as significant aspects. Whilst considering significance of existing controls, and their effectiveness shall be considered. All significant aspects shall be managed by suitable operation control procedure or management programme.

## **11. SAFETY INSPECTIONS AND FOLLOW UP ACTION**

In general HSE inspection of the whole site should be undertaken on a weekly basis and a formal report shall be issued to the main contractor.

Where the site is large and all areas cannot reasonably be inspected on a weekly basis, the Project PM shall zone the site in to smaller are as which can be inspected individually.

A risk based approach to HSE inspections must be taken and where the site is zoned high risk areas/ activities should be inspected more frequently. The monitoring plan shall be prepared to identify the frequency of HSE inspections, considering the type of work being carried out and the associated risks.

- SHE inspections shall be led by the CPWD Engineer In charge (or another senior member of the project team).A senior contractor's representative (aside from the contractor's SHE manager) must also attend the SHE inspection.
- When recording inspections the contractor Safety Manager shall use the 'SHE Inspection Form'. When completing the form as much detail as possible of each of the observations must be included and photographs should be inserted where possible for physical non-compliances. The report should make specific reference to any legal requirement that has been contravened.
- The Contractor SHE Manager shall record the specific method statement reference on the 'SHE Inspection Form' and complete the method statement noncompliance log sheet.
- Where possible the SHE inspection report should be passed to the contractor on the day that the inspection is carried out. In all cases the report must be issued within a maximum of 24 hours of the inspection being carried out.
- Contractor's SHE Manager must ensure that where an observation is marked as requiring immediate action details of the action taken at the time are recorded on the SHE inspection report. Under no circumstances should immediate action observations be left until the contractor receives the report and closes out the non-compliance in the course of time.
- The SHE Manager will ensure that the action items in the SHE inspection report are monitored and that the contractor closes out each item within the required timeframe. Where there are

concerns over the contractor's lack of action, proper notice under relevant clause shall be issued by CPWD

- The KPI for SHE inspection reports closed out against SHE inspection reports raised will be 100% within 10 calendar days of the date of inspection.
- The Contractor SHE Manager will validate close out of SHE non-compliances as he determines necessary. However, if there is any doubt or in the absence of evidence the CPWD Project Manager should check the appropriateness of the contractor's action. It is the responsibility of the contractor SHE Manager to ensure that the appropriate checks are made and determine the adequacy of the action .
- The contractor SHE Manager should maintain a simple MS Excel based log of all SHE inspections carried out on the project by CPWD. The log should include the following information:
  - a) SHE inspection reference; b) Name of Inspector;
  - Date of the inspection; c) Area/zone inspected; d) Date SHE inspection report sent to the contractor; e) Date close out report received from the contractor.
- Observations and the supervision team will send observations using the SHE Observation Form.
- These observations are to be recorded and maintained by the contractor SHE Manager for the project using the SHE Observation Log and a non-compliance category will be assigned.
- Wherever there are SHE non-compliances and they are required to take action to deal with the immediate risks. The action taken shall be recorded on the SHE Observation Form. The CPWD Project In charge shall assess the seriousness of all SHE observations and ensure that major non compliances are dealt with immediately in close coordination with coordinator.
- The contractor shall review the SHE observations and detail the preventative action they will take to prevent recurrence. The contractor shall return the completed observation log to CPWD within 7 calendar days. The Contractor SHE Manager will maintain statistics for the classification of all SHE observations and target awareness campaigns and improvement initiatives to the areas where trends or repetitive areas are identified.
- Contractor will arrange SHE Auditing as part of the SHE monitoring plan for the project.
- Contractor SHE Manager shall determine the audits to be carried out
- A target of 2 SHE audit per year (External) should be set as a minimum with additional audits requirements identified on a project by project basis.

- The Contractor SHE Manager shall ensure that advance notice of the audit is provided to the CPWD and the scope of the audit should be clearly identified. In most cases the audit will be specific to a particular activity or procedure that forms part of the contractors overall project delivery. Example of typical audits that could be carried out are as follows:-
- a) Lifting operations; b) Induction procedures; c) Hot work permit procedures d) Scaffolding arrangements; e) Excavation permit procedures; f) Plant operator competency. g) Training h) Power Hand Tools i) PPE j) fall protection k) Housekeeping l) Signage m) Welfare
- Contractor SHE audit reports will be produced in a MS Word format aligned to the following headings (include all headings and mark any non-applicable as such):-
- a) Scope and objectives of audit; b) Executive summary c) Outline of audit methodology; d) Good practices noted; e) Non-compliances; f) Observations (improvement opportunities); and g) Audit report action plan.
- Upon completion of the SHE audit, the approved audit report will be transmitted to the CPWD E-in-C or his representative either in softcopy as a Portable Document Format (PDF) via email or hardcopy or both.
- Where applicable the SHE audit report shall identify any specific contractor method statement non compliances and these should be logged in the method statement noncompliance log sheet maintained for each method statement.
- The CPWD In charge for the project will assume the responsibility for ensuring that the contractor actions have been closed out in accordance with the timescales noted in the report.
- The KPI for internal SHE audits shall be 4 per year per project.
- Internal SHE audit reports will be produced in a MS Word format aligned to the following headings (include all headings and mark any non-applicable as such):-
- a) Scope and objectives of audit; b) Executive summary c) Outline of audit methodology; d) Good practices noted; e) Non-compliances; f) Observations (opportunities for improvement); and g) Audit report action plan.
- The completed audit report will be forwarded to the CPWD E-in-C or his representative for the project who will review the contents and provide any clarifications or additional information that may be required.
- Once feedback has been received from the CPWD E-in-C for the project the author of the audit report will formally issue the report. The Contractor PM will be responsible for ensuring that any actions required are taken within the specified timeframe.

## **Documents**

- Quarterly SHE Monitoring Plan
- Observation Log (NB: a separate excel version is available for use at site)
- Observation Record Form
- Inspection Report Form

## **12. CONTACTOR'S SITE SAFETY COMMITTEES**

### **12.1 General**

All employees should be able to participate in the making and monitoring of arrangements for safety and health at their place of work. The establishment of site safety committees in which employees and Contractor and Associated Contractors/Agencies management are represented can increase the involvement and commitment of employees. The Contractor shall set up such site safety committees to promote and monitor safety and health on their worksites. A copy of the agenda shall be forwarded to the Department's Representative seven days prior to the meeting date, in order that they can decide if it is necessary for them to attend.

### **12.2 Composition and Functions of Contractor's Safety Committees**

The Contractor should form a safety committee for each contract, however should the situation require more than one committee, or the Department's Representative so requires, additional committees shall be created.

The Terms of Reference for the committee should be as follows;

- To monitor the adequacy of the Contractor's Site Safety Plan and ensure its implementation;
- To monitor safety inspection reports;
- To study accident and incident reports;
- To study accident statistics and trends so as to identify unsafe practices and conditions;
- To review the emergency and rescue procedures;
- To review site safety training;
- To promote safety and industrial health on site;
- To discuss the Contractor's monthly safety report;

- To take follow up actions on minutes of meeting.

The Membership of the committee should be as follows; Chairman: The Contractor's most Senior Manager for the Contract.

Secretary: The Contractor's Safety Officer

Members: Contractor's and Associated Contractors/Agencies s management representatives and safety staff.

Representatives of the Department and the Department's Representative Member of labour representative.

Meetings should be held at least once every month

Minutes of the Site Safety Committee shall be sent to all members within two working days of the meeting. Copies of the minutes should be displayed on notice boards so that employees are kept informed of the Site Safety Committee's activities and decisions.

The frequency of the meeting should be at least once in a month (not before 21 days) and the MOM (Memorandum of meeting) should be circulated to all the members of the committee and displayed at all prominent locations in local language within two days after the meeting.

### **12.3 The Agenda should consist of minimum of the following points:**

- To monitor the adequacy of the Contractor's Site SHE Plan and ensure its implementation;
- To monitor SHE inspection reports;
- To study accident and incident reports and proposed remedial action status;
- Study of first aids and remedial action status.
- To study accident statistics and trends so as to identify unsafe practices and conditions;
- o review the emergency procedures and First Aid arrangements;
- To review site SHE training and Tool Box Talk (TBT);
- To promote safety and occupational health on site (by safety awards & motivation programmes)
- To discuss the Contractor's monthly SHE report;
- To take follow up actions on previous minutes of meeting.

## **13. REPORTING OF ACCIDENTS AND DANGEROUS OCCURRENCES**

### **13.1 Contractors Responsibility**

- All accidents and dangerous occurrences shall be recorded, regardless of whether or not personnel injury occurs.
- The Department and the Department's Representative shall be notified by the quickest possible means, for example by telephone of the following classifications of accidents and incidents and by subsequent written notification within twenty four hours on the Accident and Incident Reporting.
  - Fatal Accident
  - Major Injury Accident
  - Dangerous Occurrence
  - Any Incident Involving A Member Of The Public
- The Site SHE Manager shall conduct in depth investigations into all fatal accidents, major injury accidents, incidents involving a member of the public, dangerous occurrences, and selected over three-day lost time injury accidents. Copies of these investigations shall be forwarded to the Department's Representative within seven days of the incident.
- The Contractor shall report immediately, orally and in writing, all fatal accidents, and other occurrences requiring reporting, to the police, at the police station in whose jurisdiction the accident occurred.

### **13.2 Reportable Accidents**

- An accident shall also become reportable to the Department's Representative if it causes incapacity for more than three days excluding the day of the accident. The Contractor must submit a report to the Department's Representative within seven days of the incident.
- The following information is required as minimum in reporting an accident to the Department's Representative.
  - A. particulars of the Contractor or Associated Contractors/Agencies employing the injured person;
  - B. particulars of the deceased or injured person: name, address, occupation, sex, and age;
  - C. the date, cause or circumstances of the accident; and

D. the nature of the injury, stating whether death or incapacity was caused by the injury.

### **13.3 Dangerous Occurrences**

- The Department's Representative requires that all dangerous occurrences on site must be reported in writing to him within 24 hours, irrespective of whether there are casualties or not. The following information has to be provided:
  - A. the time of the occurrence;
  - B. damage to any building, machinery or plant; and
  - C. the circumstances in which the accident occurred.
- If no one is injured, the above notification is sufficient. In the case of death or serious injury, the accident reporting procedure outlined in Section 9.1.2 must also be followed.

### **13.4 Reporting of Fires by Contractor**

- The Contractor shall report to the Department's Representative all fires which occur on site including any fires that have been extinguished by the Contractor himself, and the Department's Representative may send staff to investigate such fires. The following information should be provided:
  - A. time of fire;
  - B. location of fire;
  - C. means of extinguishing the fire;
  - D. injury to any person/damage to any property; and
  - E. the probable cause of fire.

This action is in addition to reporting the incident to the Chief Fire Officer, and Police in accordance with local regulations.

### **13.5 Reporting to the Department's Representative**

- The Contractor shall duly complete standard forms on dangerous occurrences and accidents as required by the Department's Representative to enable the Department's Representative to prepare a database on accident statistics. The Contractor shall deliver to the Department's Representative a copy of any statutory reports he submits to the Relevant Authorities.
- The Contractor shall send a monthly report to the Department's Representative of all accidents

and dangerous occurrences whether they are of a serious nature or not.

### **13.6 Reporting to government organizations**

- In addition to the above verbal and written reporting to the Department, as per Rule 210 of BOCWR, notice of any accident to a worker at the building or construction site that:
- Causes loss of life; or disables a worker from working for a period of 48 hours or more immediately following the accident;
- Shall forthwith be sent by telegram, telephone, fax, or similar other means including special messenger within four hours in case of fatal accidents and 72 hours in case of other accidents, to:
- the Regional Labour Commissioner , wherein the contractor has registered the firm/work
- The board with which the worker involved was registered as a beneficiary;
- Director General, Min. of Labour and
- The next of kin or other relative of the worker involved in the accident;

## **14. ACCIDENT INVESTIGATION**

### 14.1 General

- Investigations should be conducted in an open and positive atmosphere that encourages the witnesses to talk freely. The primary objective is to ascertain the facts with a view to prevent future and possibly more serious occurrences. Accidents are rarely just the fault of the worker. If the worker has not been trained, instructed or properly supervised then the fault may well lie with management.
- Accidents and Dangerous Occurrences which result in death, serious injury or serious damage must be investigated by the Contractor immediately to find out the cause of the accident/occurrence so that measures can be formulated to prevent any recurrence. (Refer to the advice contained in 10.2.1 below.)
- Near misses and minor accidents should also be recorded and investigated by the Contractor as soon as possible as they are signals that there are inadequacies in the safety management system.

### **14.2 Recommended actions in incident investigation**

incident is gathered in an organized way. The following steps are recommended;

- take photographs and make sketches
- examine involved equipment, work piece or material and the environmental conditions
- interview the injured, eye-witnesses and other involved parties
- consult expert opinion where necessary
- Identify the specific Contractor or Associated Contractors/Agencies involved.
- Having gathered information, it is then necessary to make an Analysis of Incident
- establish the chain of events leading to the accident or incident
- find out at what stage the accident took place
- Consider all possible causes and the interaction of different factors that led up to the accident, and identify the most probable cause.

Note: The cause of an accident should never be classified as carelessness. The specific act or omission that caused the accident must be identified.

Ø The next stage is to proceed with the Follow-up Action

- report on the findings and conclusions
- formulate preventive measures to avoid recurrence
- publicize the findings and the remedial actions taken

## **15. ACCIDENT STATISTICS**

### **15.1 Introduction**

Accident data, if properly collected and analysed, indicates trends, and can show where and how Problems arise. Comprehensive accident information enables accident prevention efforts to be targeted at problem areas.

### **15.2 Collection of Accident Statistics**

Ø The procedures that apply for the reporting and collation of data in respect of accident statistics are set out below.

Ø The Contractors' safety officers are required to send duly completed Report Forms to the Department's Representative within five days after the end of each month. The Construction

Accident Statistics Monthly Report Form must be submitted even if there are no injuries or dangerous occurrences within the current month.

Ø 'Man-hours' is defined as the man-hours worked by all persons employed on site. (Including site supervisory staff, management staff and clerical staff).

Ø 'Man-days' is defined as the man-days worked by all persons employed on site. (Including site supervisory staff, management staff and clerical staff).

## **16. RISK ASSESSMENT**

### **16.1 General**

The purpose of Hazard Identification and Risk Assessment is to identify all the significant hazards, which may occur during the construction phase, and to rank them according to their severity. Having ranked the risks by severity the Contractor shall then introduce measures to mitigate the effects of that risk.

Prior to the commencement of any potential High-Risk operations the Contractor shall conduct a detailed hazard analysis and risk assessment of the task and shall record his findings on appropriate worksheets.

The worksheets should then show what measures the Contractor is going to take to reduce the level of risk to acceptable levels.

### **16.2 Job Safety Analysis (JSA)/SWMS/ Safe work Method Statement (SWMS)**

**A JSA is required for the following:**

- High risk jobs
- New jobs or tasks
- Tasks involving new equipment, or procedures.
- Major job categories that will be repeated frequently
- Tasks that historically have significant rate of incident
- Jobs involving environmental or hazardous waste.
- Jobs that, in the judgment of the responsible SHE Manager, require a formal JSA

Safe Work Method Statement (SWMS)/Job Safety Analysis (JSA) must be prepared by the Contractor for the proposed work and reviewed and approved prior to work being authorised to

commence. The proposed work must be conducted according to the safety procedures in the SWMS.

### **16.3 Method Statement**

For critical activities having high ranking of risks, method statement / Quality Control Procedure should be developed by the Contractor. For all other activities, risk assessment should be performed, documented and should be made available at place of work. Typically critical activities are:

- Crane age of items in excess of 1 tone
- Erection of steel structures.
- Excavations deeper than 2m.
- Erection and loading of formwork
- Demolition.
- Tunnelling operations.
- Inflammable materials – the use and storage
- Use and storage of explosives
- Hot work (welding, cutting and grinding etc)
- Height work (above man height)
- Using power tools
- Concrete work
- Shuttering and de-shuttering work
- Lifting and shifting of materials (Crane operation)
- Machineries operation
- Work in confined spaces
- Painting work
- Waterproofing
- Handbook Handling of materials

- Working in hot weather
- Buried and overhead services
- Erection of tower crane

Note : As Applicable to the Work

A method statement should contain the following:

- Detailed sequence of work in chronically order.
- Management arrangements including identified person with authority
- Drawing and technical specification
- Detail information on plant, equipment, substance etc.
- Inspection and monitoring control
- Risk assessment
- Emergency procedure and system
- Arrangement for delivery, stacking, storing and ,movement of logistics on site
- Details of site features, layout and access which may affect the method of working
- Procedure for charging or departing from the method statement

#### **16.4 Permits to Work**

The Contractor shall develop a permit-to-work system, which is a formal written system used to control certain types of work that are potentially hazardous. A permit-to-work is a document, which specifies the work to be done, and the precautions to be taken. Permits-to-work form an essential part of safe systems of work for many construction activities. They allow work to start only after safe procedures have been defined and they provide a clear record that all foreseeable hazards have been considered. Permits to Work are usually required in high-risk areas as identified by the Risk Assessments.

A permit is needed when construction work can only be carried out if normal safeguards are dropped or when new hazards are introduced by the work. Examples of high risk activities include but are not limited to:

- Work close to 25kV overhead Catenary

- Entry into Confined Spaces.
- Work In Close Proximity to Overhead Power lines and Telecommunication Cables.
- Hot Work.
- To dig—where underground services may be located.
- Work with moving construction locomotives.
- Working On Electrical Apparatus.
- Work with Radioactive isotopes.

The permit-to-work system should be fully documented, laying down:

- how the system works;
- the jobs it is to be used for;
- the responsibilities and training of those involved; and
- how to check its operation;

The permit-to-work form must help communication between everyone involved. It should be designed by the Contractor issuing the permit, taking into account individual site conditions and requirements. Separate permit forms may be required for different tasks, such as hot work and entry

Into confined spaces, so that sufficient emphasis can be given to the particular hazards present and precautions required.

The permit to work form should contain:

- A. clear identification of who may authorize particular jobs (and any limits to their authority);
- B. clear identification of who is responsible for specifying the necessary precautions (e.g. isolation, emergency arrangements, etc);
- C. a detailed description of the task clearly identifying the work to be done and the associated hazards;
- D. plans and diagrams be used if appropriate to assist in the description of the work to be done, its location and limitations;
- E. identity of the hazards and the precautions to be taken;

G. the time limitations should be stated;

H. job specific toolbox talk conducted by the supervisor

A Permit to Work authorization form shall be completed with the maximum duration period not exceeding twenty four hours (for example of a Permit to Work authorization form.

A copy of each Permit to Work shall be displayed, during its validity, in a conspicuous location in close proximity to the actual works location to which it applies.

A pre-permit activation job specific toolbox talk shall be conducted by the supervisor including amongst others the following.

- All identified hazards are explained;
- Risk mitigation process clarified;
- Method of work explained stressing points (a) and (b) above;
- Emergency response procedure is clarified and persons assigned tasks in the event of an emergency;
- PPE requirements including PPE serviceability checks and training if required;

All workers and supervision shall attend the toolbox talk and sign the toolbox attendance register. Any person/s coming late to the work site shall be given the toolbox talk and sign the attendance register.

A copy of the toolbox talk and attendance register shall be displayed.

## **17. WORKING HOURS**

All applicable Indian National and state specific legal requirements related to working hours shall be followed by the Contractor under any/all circumstances.

Normally the work shall be carried out during daylight hours. If during the course of the project night work is required, all support facilities such as the lighting shall be provided in order to keep the safe working conditions. No persons shall be permitted to work continuously day & night.

No workers shall be allowed to work for more than 8 hrs/day or 48 hrs a week excluding overtime. One day off/week is must and no deduction for the same.

Maximum 60hrs/week shall be allowed including overtime. Overtime should not exceed 50/quarter.

An attendance register to be maintained on site to monitor the working hours. Register shall not be manipulated in any case/ no whitener/correction will be permitted.

## **18. SMOKING**

Smoking is prohibited in Public Place as per prevailing legislation. The same rule shall be in effect at the work site. Smoking shall be strictly prohibited at all locations designated by “NO SMOKING” signs.

## **19. FIRST AID AND TRAINING**

Training on first aid shall be organized for all site staffs and workers by qualified doctor / competent

Authority initially on start of work and thereafter at every six months, interval. The names of the trained first aiders shall be displayed at all prominent work locations

## **20. EMERGENCY PREPAREDNESS PLANS**

### **20.1 Emergency Situations**

Every Contractor shall formulate an Emergency Preparedness Plan for each of his sites. These plans will address foreseeable emergencies that may arise during the construction activities. Examples of activities for which plans should be prepared include amongst other things:

- An Accident Which Results In Death or Major Injury
- A Serious Fire That Threatens Life.
- A Flood That Threatens Life.
- Leakage of Any Dangerous Materials or Chemicals
- Leakage / Short Circuit of any Electrical supply.

Major Engineering Failures such as: collapse of tunnels or structures major utility collapse Unintended explosions subsidence causing damage to structures or services

A. An Emergency Preparedness plan should include details of the following;

- The name, location and phone number of the Emergency Co-coordinator;
- Designated Personnel with locations and phone numbers;
- Details of the Emergency Response Team with locations and phone numbers;
- Functions of the Emergency response Team;
- The means of Escape;

B. Communication with the emergency Services;

- Police
- Fire Services
- Ambulance and Hospital Services

C. First-Aid Facilities;

- a). Site plans;
- b). Suppliers of emergency equipment such as sump pumps, lighting, craneage, etc.

D. Copies of the emergency procedures and the Contractor's rescue organization (reviewed without objection by the Department's Representative) should be displayed at each place of work and notice boards. This information should be reviewed and updated as often as is required, but at least once annually. Drills should be arranged to test the efficiency in mobilizing the necessary personnel and equipment. These Drills should be carried out at least every three months.

E. Regular joint exercises between the Contractor's rescue teams and the Fire and Emergency Services should also be carried out.

**20.2 First Aid**

Qualified First aid and First aid facilities shall be a teach work place. Every injury shall be reported and treated. First aiders shall be in possession of a valid first aid certificate issued by a competent authority. The first aid facility shall be in accordance with applicable Laws. Alternatively the agreements shall be made with nearby hospital for treatment of injured or person suffering from sickness. A first aid log will be maintained for injuries and sickness. Agreement should have provision to provide ambulance service on call basis or for deputing at site case of critical activity on stand by during work hours.

**20.3 Ambulance Van**

The contractor shall ensure at construction site that an ambulance van for transportation of serious cases of accident or sickness of building workers to the hospital promptly and such ambulance van is maintained in good condition and is equipped with standard facilities specified in schedule V, BOCWA

**20.4 Tie-up with nearby Hospital**

During construction, the Contractor shall Tie-Up with nearby hospital to arrange medical treatment in serious cases of accident or sickness of the building worker promptly.

**21. SAFETY SIGNAGE**

**21.1 Safety Signs**

4 All safety signage that is displayed in and around the sites shall be in both Hindi and English and local language, examples of signs that shall be required shall include amongst others the following:

- Wear Safety Helmets.
- Permit to Work areas
- Wear Safety Footwear.
- Wear Hearing Protection.
- Wear Eye Protection.
- Danger Electricity.
- Danger Crane Overhead.
- Stop Look and Listen
- No Smoking.
- First Aid.
- No Entry signs
- Fire precautions.
- Emergency Exit from underground works
- Safe access
- Deep excavation under progress Mind the gape
- Debris following area
- Blasting area

B. All safety signs shall comply with the Internationally recognized Safety Colours as indicated below:

Blue : Mandatory

Yellow : Danger

Red : Prohibition

Green : Safe condition References Indian Standards

IS 9457 Standard for colours of Safety Signs IS . 12349: 1988 Fire Protection - Safety Signs . Apart from that, Contractor should also maintain the list of safety signage's displayed at the site with proper name and location.

## **22. INDUSTRIAL HEALTH AND WELFARE**

### **22.1 Introduction**

- A Hazards to Health on a construction site can arise from the use of a number of materials, substances and processes if they are not properly controlled. Some of the more serious risks are caused by the inhalation of dusts, fibers, toxic fumes, by the misuse of chemicals, lasers and radioactive isotopes. Excessive vibration and excessive noise can also cause ill health. Many man- days are lost as a result of dermatitis, tenosynovitis, bronchitis and rheumatism.
- B The Contractor shall be responsible for maintaining healthy working conditions for all his, and his Associated Contractors/Agencies s, workers. In particular he shall pay attention to the effects of noise, dust, air pollution and the use of chemicals. If it is not possible to remove the cause of harm then suitable and sufficient Personal Protective Equipment (PPE) should be provided to those workers who could be affected.
- C If the use of PPE is the only means of providing protection the Contractor shall ensure that all the workers affected are properly trained in the use of the PPE and that adequate supervision is provided to ensure its proper use.

### **22.2 Hazardous Substances**

- A The Contractor shall obtain Material Safety Data Sheets (MSDS) for all substances that are deemed to be hazardous to be used on site. An inventory shall be kept of all such materials with the relevant MSDS and shall be available for inspection by the Department's Representative who may require further MSDS's to be obtained.
- B The Contractor shall conduct an assessment of the substance in relation to its intended usage on site. Particular attention must be given to the actual location of usage as a substance, which is safe for use in the open air, may be extremely hazardous in a confined space. The results of all assessments shall be recorded and method statements produced.
- C The objective of the assessment is to establish what precautions and control measures shall be implemented in order that a safe system of work can be established for the use of the substance on site.

### **22.3 Noise**

- A Industrial deafness is caused by over exposure to high levels of noise from plant, machinery or

struction processes. Once a part of a persons hearing has been lost it can never be recovered. Deafness can also lead to further accidents on site with workers being unable to hear warnings and other instructions.

- B For continuous exposure, i.e. for eight hours in any one-day, the sound level should not exceed 85dB(A). For non-continuous exposure a calculated equivalent continuous sound level (Leq) should not exceed 85dB(A). Workers should not be exposed to sound levels exceeding 85dB(A) unless they are wearing suitable hearing protectors, which effectively reduce the sound level at the user's ear to, or below, 85dB(A).
- C If Peak noise levels exceed 85dB(A) then the wearing of suitable hearing protectors shall be Mandatory.
- D The Contractor shall carry out noise assessments to establish what noise levels his workers are being exposed to. If excessive noise levels above 85dB(A) are found then the contractor shall introduce a noise control programme to protect his workers.
- E Consideration should always be given first to reducing the noise level at source. Examples of noise reduction methods include;
- More efficient silencers on compressors and maintenance of exhaust systems;
  - Fitting acoustic lining to machinery panels;
  - Use of Acoustic screens and sheds to protect other workers;
  - Using noise reduced tools;
  - Sighting of noisy plant away from the workplace
- F Where it is not possible to reduce the noise level to which the worker is exposed the Contractor shall provide the workers with suitable and sufficient hearing protection to protect them. The Contractor shall ensure that all the workers affected are properly trained in the use of the Hearing Protection and that adequate supervision is provided to ensure its proper use.

#### **22.4 Ventilation in Shafts and Tunnels**

- A The contractor shall assign a Competent Person to perform all air monitoring required to determine proper ventilation and quantitative measurement of potentially hazardous gases. The atmosphere in all underground areas shall be tested quantitatively by the contractor for toxic gases, dust, vapour, mist, and fumes as often as necessary to ensure that prescribed limits given at 15.4.3 below are met. Quantitative tests for methane shall also be performed in order to determine whether an operation is

potentially hazardous. For every test carried out the contractor shall maintain a record of the air quality the location, date, time, substances and amount monitored. These records shall be made available to the Department's Representative on demand.

B The ventilation system shall be adequate to maintain circulation of air in all parts of tunnels and shafts and following conditions shall be taken care of:

C Air shall be considered unfit for workmen to breathe if it contains any of the following:

- Less than 19.5% oxygen by volume.
- More than 0.005% carbon dioxide by volume.
- More than 0.01% carbon monoxide by volume.
- More than 0.001% hydrogen sulphide by volume.
- More than 0.005% oxides of nitrogen.
- More than 0.5% of methane at any place in the tunnel.
- More than 0.0002% of aldehyde.
- Any other poisonous gas in harmful amounts.

In addition to the requirements given above, 2 m<sup>3</sup> of fresh air per minute shall be furnished for each brake horsepower of diesel engine used in the tunnel.

The Contractor will ensure the supply of fresh air to all underground work areas in sufficient amount

To prevent any harmful accumulation of dust, vapour or gases. The contractor shall provide at least 4.25 m<sup>3</sup> of fresh air per minute per employee underground.

- No inflammable materials or oil and grease shall be stored inside or near the tunnels or shafts and all combustible rubbish from the tunnel or shaft shall be promptly removed. A regular analysis of the gases inside the tunnel should be done with advance of the tunnel.
- Tools made of light alloys (such as Al and Mg) are not to be used inside the tunnel. They may cause sparks.
- Regular checking of gas at the faces shall be done before each shift. This should be carried out using a multi gas detector.
- Motive power other than electric, shall not be used without prior authorization from the Department's representative. No petrol engines shall be used underground. Diesel locomotives

shall only be used with the prior consent of the Department's Representative. Diesel engines shall not be used underground unless equipped with a filter that will remove all carbon monoxide and oxides of nitrogen. Such filters shall be tested by the Contractor's chief mechanic and more frequently by the plant operator.

## 22.5 Lifting and Carrying of Excessive Weights

All contractors shall ensure that no worker lifts by hand or carries overhead or over his back or shoulders any material, article, tool or appliances exceeding in weight the maximum limits set out below unless aided by another worker or a mechanical device.

Adult – man 55kg Adult – female 30kg

### References

Building And Other Construction Workers (Regulation of Employment and Conditions of Service) Rules 2002

### Indian Standards

IS 4756 : 1978 Safety Code for Tunnelling works

IS 1179 : 1967 Specification for equipment for eye and face protection during welding  
IS 2925 : 1984 Specification for Industrial Safety Helmets

## 22.6 Workers accident insurance

The Contractor provides accident insurance to all Workers, covering medical treatment for work related accidents and compensation for work related accidents resulting in permanent disability.

Workers whose salary is less than Rs.25000/month should be covered under ESIC insurance. All others will be covered under group personnel accident insurance. WC policy to be ensured for those workers who will work for the period of less than a month.

inclusion of following references but not limited to, legal and other requirements also apply:

The work men's Compensation Act, 1923	Indian Labour Law	Certain classes of employee to be provided for compensation for injury by accident.
The Payment of Gratuity Act, 1972	Central Government of India	Gratuity to be paid to the employees on the termination of his employment after he has rendered continuous service for not less than five years
The Sexual Harassment of Women at Workplace (Prevention, Prohibition and Redressal) Act, 2013	Ministry of Women and Child Development	To provide protection against sexual harassment of women at workplace and for the prevention and redressal of complaints of sexual harassment.
The energy conservation Act, 2001	Ministry of Power/energy	Reduce the power consumption,
The municipal solid waste rules 2000 & 2006	Ministry of Environment and Forest	Reduce the office waste (paper, tissue, cardboard food waste etc.)

E-waste management rules 2011	Ministry Environment of and Forest	E-waste to be stored securely and disposed through authorized recycler.
(Prevention and control of pollution) cess Act, 1977 amendment 1992. Environmental Protection Act, 1986	Ministry Environment of and Forest	Water conservation.
Ozone depleting substances (Regulation and control) Rules 2000	Ministry Environment of and Forest	Control depleting ozone substances.
Register Of Persons Employed As Building Workers	BOCW Act, 1996	Maintain in respect of each registered establishment, where he employs building workers.
Display Of Notice Of Wages.	BOCW Act, 1996	The date, place and time of wages to be paid shall be displayed at the working area in Hindi, English and local language.
Drinking Water	BOCW Act, 1996	Provide the sufficient supply of wholesome water, provided and maintain at suitable locations for all persons, with properly marked as "Drinking Water".
Accommodation	BOCW Act, 1996	Provide free of charge within the work site or near to it, temporary living accommodation to the workers for such period till the construction work in progress.
Safety Committee	BOCW Act, 1996	Wherein 500 or more workers are ordinarily employed, there shall be a safety committee.
Safety Officer	BOCW Act, 1996	Whenever the workers employed are less than 500, or more a safety officer shall be appoint.
Fire Protection	BOCW Act, 1996	Construction sites shall be provided with suitable fire extinguisher, adequate water supply with ample pressure and the trained persons.
Emergency Plan	BOCW Act, 1996	Ensure at a construction site, where more than 500 workers are employed, proper emergency action plan is maintained.

Health, Safety And Environment Policy	BOCW Act, 1996	Establishment 50 or more building workers shall prepare a written statement of policy.
Eye Protection	BOCW Act, 1996	Suitable personal protective equipment shall be provided by the employer to the worker.
Head Protection And Other Protective Apparel	BOCW Act, 1996	Every building worker require to pass through or working within the areas where there is hazard of his being struck by falling objects shall be provided by the safety helmets. If the worker is working in water or wet concrete, he should be provided by the water – proof boots.
Electrical Hazard	BOCW Act, 1996	Adequate measure to prevent the worker to directly come into contact with any electrical equipment or live electrical circuit.
Vehicular Traffic	BOCW Act, 1996	Construction work is being carried on or is near the proximity of a road, the employer shall ensure that the construction work place is barricaded and suitable warning signals are displayed.
Illumination	BOCW Act, 1996	Employer shall ensure that all work places where excavation work is done shall be illuminated according to the national standard.
Stacking of Material	BOCW Act, 1996	Shall ensure that all building materials are stored or stacked in a safe and orderly manner to avoid obstruction of any passageway or place or work.
Disposal of Debris	BOCW Act, 1996	Debris are handled and disposed of by a method, which does not cause danger to the safety of a person.
Lifting Appliances and Gears	BOCW Act, 1996	Construction and maintenance of lifting appliances: all appliances including their parts, whether fixed or movable shall be of sound material and adequate strength.

Lifting Appliances and Gears	BOCW Act, 1996	Construction and maintenance of lifting appliances: all appliances including their parts, whether fixed or movable shall be of sound material and adequate strength.
Transport Equipment	BOCW Act, 1996	All vehicles shall be of good material and proper design and of sufficient size to carry the containers. All such vehicles are inspected at least once a week.
Monthly Report	BOCW Act, 1996	Monthly Report on SHE Statistics to be sent by 7 <sup>th</sup> of every month.
Rule 34	Excessive noise, Vibration Noise level in no case exceeds the limit of 90dbA	Noise not to exceed limits specified in schedule VI - 90dbA for 8 hours. Vibration not to be excessive
_____ <u>Rule 35</u>	Fire Protection, Fire extinguishing equipment , Trained persons required operating the fire extinguishing equipment	Adequate Fire Extinguishing equipment, water supply with ample pressure (as per national standards) & trained persons to operate extinguishing equipment
<u>Rule 36</u>	Emergency Action Plan	Plan to handle fire, explosion, collapse of lifting, transport equipment, building or structure, gas leakage/spillage of dangerous goods/ chemicals, storms & other natural calamities-to be made and submitted to Chief Inspector of Inspections of Blg & Const.
<u>Rule 37</u>	Fencing of Motors	All moving parts of machines are fenced. No cleaning of machines done while in motion. Fencing is not removed while machines are in motion.
_____ <u>Rule 38</u>	Lifting and carrying of excessive load	No worker will carry weights more than stipulated as in BOCW Rule. If more weight to be carried shall be assisted by mechanical device.

<u>Rule 39</u>	Health and Safety Policy	Site specific safety policy to be made as BOCW stipulations and displayed at prominent locations. In local language also.
<u>Rule 41</u>	Overhead Protection	Overhead protection extending 2 meters from the periphery of building with inward slant to be provided at 5 m height from the base of the building. Cordon off areas where fall of object is possible and prevent inadvertent entry of people other than building workers working there.
<u>Rule 42</u>	Slipping, tripping , cutting, Drowning, and falling hazards	All passage ways clear for movement devoid of debris, pointed objects, slippery surface, protruding nails etc. Caution and effective prevention of falling off edge by barricades. Issue of PPE including Safety harness for prevention of fall from height.
<u>Rule 43</u>	Dust Gases and fumes	dust and gas to be controlled
Rule 44	Corrosive Substance	Control and caution in use of corrosive substance and contain spillage.
<u>Rule 45</u>	Eye Protection	Eye protection for specific uses issued to workers.
Rule 46	Head Protection and other protective apparels	Appropriate PPE's for workers.
Rule 47	Electrical Hazards	Electrical hazard caution board displays, caution against worker getting in contact with live parts, PPE's suitable for shock proof working, provision and maintenance of ELCB's proper cable routing
<u>Rule 48</u>	Vehicular Traffics	MV rules shall be followed. Pedestrian traffic separated from vehicle traffic. License of driver as per the class of vehicle.
Rule 50	Illumination of passageways etc.	Passage ways shall be adequately illuminated as per national standards.
<u>Rule 51</u>	Stacking of materials	Orderly and stable stacking of materials. Material stored according to capacity of platform/slabs.

<u>Rule 52</u>	Disposal of debris	Debris not allowed to accumulate and handled in a way not dangerous to workers. Kept moist to bring down dust level. Debris not thrown from top.
Rule 53	Numbering and marking of floors	All floor landings should be numbered.
Rule 54	Use of safety helmet and shoes	All workers provided helmets and safety shoes
Rule 55	Construction and maintenance of lifting appliances	Sound construction of good strength for lifting appliances .Good maintenance. Unrestricted view for the operator from his seat. Automatically comes to neutral position during failure of power.
<u>Rule 56</u>	Test and periodic examination of lifting appliances	Lifting appliances inspected and certified by competent person before use. Examined and certified by competent person every 12 months thereafter.
<u>Rule 57</u>	Automatic safe load indicator	Safe Load Indicator(SLI) shall be available on all lifting and warning shall be given when the load increases above safe load
<u>Rule 58</u>	Installation	Fixed lifting appliances installed by competent person. Precautions against danger for operator, distance from fixed walls ,buildings and power lines
<u>Rule 65</u>	Hoist	Hoists are designed as per national standards. Gates to approaches to the hoist are fitted with gridded cage to enable visibility. Equipped with devices which requires such gates to be closed before the hoist leaves the floor and opens only when the hoist platform is on that floor. Approaches to a hoist is adequately lit.
<u>Rule 74</u>	Register of periodical test, examination and certificates thereof	Register in Form XXVI to be maintained. Certificate of testing/examination under rule 56 and 71 to be obtained from competent person in various forms.
<u>Rule 78</u>	Hoist carrying	Have interlocks with hoist gate and landing

<u>Rule 88</u>	Earth Moving Equipment and Vehicles	All transport vehicles inspected every week by a responsible person and found with any defect, take out of service. All lights horns and brakes of tractors and other vehicles kept in good repair. Unauthorized person rides the transport vehicle. Experienced operator/driver.
Rule 95	General Safety (vehicles)	silencers for all earth moving equipment and vehicles and also reverse alarm, brakes, tail lights etc.
<u>Rule 96</u>	General Provisions regarding use of concrete	Plans, schemes and technical details regarding methods for safe placing and handling of materials, type, quality and arrangement of each part of a structure, sequence such as formwork and shores used for concrete work are structurally safe and braced together to retain shape of formwork are all specified. Wire nets or screen netsto contain falling objects.
<u>Rule 97</u>	Preparation and pouring of concrete and erection of concrete structures	Building worker handling cement or concrete wears closely fit clothing, hard hat, safety goggles, proper footwear and respiratory mask to protect him from danger
<u>Rule 99</u>	Pipes and Pumps	Scaffold supporting concrete pipes shall be of sufficient strength and should also carry the worker standing on it safely. All pipes are properly secured at curves and at the top end. Securely attached to pump nozzle using collar. Workers around the pump uses goggles.
Rule 103	Vibrators	Vibrators operated by physically fit operators, all practical measures used to reduce vibration transmitted, electrically operated vibrators are earthed. Leads of vibrators are heavily insulated. Kept off when not in use.
Rule 104	Inspection and supervision	Erection of form work, shores braces and other supports are supervised by responsible person. Person responsible

		shall inspect the same when the concrete is placed and any unsafe condition found is remedied immediately.
<u>Rule 105</u>	Beams, floors and roofs	All horizontal and transverse bracings are in place for rendering the form work structurally safe. Shores are seated on top and bottom properly. Engineer designing the formwork responsible for supervision and stability of Form work structure.
<u>Rule 106</u>	Stripping	Certified by responsible person for setting of concrete before DE shuttering and certificate maintained for inspection. Shuttering panels stacked properly to allow hassle free movement of workers. Protruding nails form accessories not required should be removed.
<u>Rule 107</u>	Reshoring	Reshoring to support beams or slabs when such beams and slabs are subjected to superimposed loads due to construction above that slab
<u>Rule 172</u>	Construction and safe use	Every ladder or step-ladder used in building or other construction work is of good construction, made of sound material and of adequate strength for the purpose for which such ladder or step-ladder is used
Rule 173	Rungs	The contractor shall ensure at a construction site of a building or other construction work that no ladder is used which has a missing or defective rung or a rung which depends for its support solely on nails, spikes or other similar fixing
Rule 175	Catch platforms	Catch platform is not used for storage of material or as a working platform catch platform is at least two meters wide and is inclined so that the position of outer edge of such platform is fifteen hundred millimeters higher than the inner edge the open end of catch platform is properly fenced

		to the height not less than one meter
<u>Rule 176</u>	Hoardings	The employer shall ensure at a construction site of a building or other construction work that hoardings are constructed when the Registering Authority/ Assistant Labor Commissioner considers it necessary for protection of building workers and directs such employer to construct such hoardings
Rule 177	Chutes, its construction and use	<p>All openings of chutes except their top openings are closed when not in use;</p> <p>(c) every chute- (i) is constructed of sound material, adequate strength and is suitable for the purpose it is intended for use;</p> <p>(ii) exceeding twelve meters in height is constructed in accordance with the design and drawings of a professional engineer for such construction and approval of the Chief Inspector of Inspections of Building and Construction or any other person authorized by him a suitable warning notice is displayed at <sup>(d)</sup> conspicuous location, written in Hindi and in a local language, at the discharge end of every chute.</p> <p>every chute is cleared when debris has accumulated to a height which can pose danger to building worker but such clearance is done in no case less frequently than once a day.</p>

<p><u>Rule 178</u></p>	<p>Safety belt and its use</p>	<p>safety belt, life lines and devices for the attachment of such life lines conform to the relevant national standards. Every building worker is supplied with safety belt and safety life lines for his protection and such building worker uses such belts and life lines during the performance of his work All building workers using safety belts and safety life lines have the knowledge of safe use and maintenance of such belts and life lines and are supplied with necessary instructions for its use the responsible person for supervising the use of safety belts and safety life lines referred to in clause (b) inspects and ensures that such safety belts and life lines are fit for use before taken into use at every time</p>
<p><u>Rule 179</u></p>	<p>Safety net and its use</p>	<p>every safety net is of adequate strength, made of sound material and is suitable for use and conforms to the relevant national standards the responsible person for maintenance of safety nets and their use ensures safe fixing of such safety nets and provides such safety nets with suitable and sufficient anchorage so that the purposes for which such safety net is intended for use, is served</p>
<p><u>Rule 180</u></p>	<p>Storage of safety belts and nets, etc.</p>	<p>proper arrangement is made for the safe storage of safety belts, safety life lines and safety nets when they are not in use and are protected against mechanical damage, damages from chemicals and damages from biological agents</p>
<p>Rule 181</p>	<p>General provision</p>	<p>The trained building worker under the direct supervision of a person, responsible for structural frame and form work, are employed for erection of such structural frame or form work, dismantling of building and structure and performance of an engineering work, form work, false work and shoring work</p>

Rule 182	Form Work false work and shoring	Form work and false work are so designed, constructed and maintained that such form work and false work support the load that may be imposed on them. such form work is so erected that working platform, means of access, bracing, means of handling and stabilizing could easily be fixed with such form work
Rule 184	Form work	Inspects and examines the material, timber, structural steel and scaffolding for its strength and suitability before being taken into use. A responsible person for structural frame and form work
Rule 185	DE shoring	when shoring is removed, sufficient props are left in place of such shoring to prevent any possible hazard; and de- shoring is adequately braced or tied together with support to prevent any hazard
Rule 186	Stacking and unstacking of materials and articles	Material should be stacked on firm foundation not liable to settle. The material or articles, are not stacked against partition or walls of a warehouse or store place. The materials or articles are not stacked to such a height and in such a manner as would render the pile of such stack unstable and cause hazards to the building workers
Rule 188	Scaffold construction	All metal scaffolds used in building or other construction work conform to the relevant national standards. Every scaffold and every component thereof is of adequate construction, made of sound material and free from defects and is safe for the purposes for which it is intended for use.

Rule 189	Supervision by a responsible person	No scaffold is erected, added, altered or dismantled except under the supervision of a responsible person for such erection, addition, alteration or dismantling
<u>Rule 190</u>	Maintenance	The scaffold used in building or other construction work is maintained in good repairs and the measures are taken against its accidental displacement or any other hazard in case the remaining part of such scaffold cannot be used by the building worker's necessary warning notice written in Hindi and in a language understood by the majority of the building workers that such scaffold is unfit for use, is displayed at the place where such scaffold is erected
Rule 191	Standards, ledger, putlogs	Plumb where practicable, adequate measures are taken to prevent displacement of a standard of a scaffold either by providing sole plate or a base plate, as necessary ledgers of metal scaffold are placed at vertical intervals spaced, as close as practicable with due regard to safety and stability of such scaffold
Rule 192	Working platform	The safe working load and the number of building workers to be employed in each bay of a scaffold are displayed for the information of all the building workers employed at such construction site
<u>Rule 193</u>	Board, plank and decking	Board, plank and decking used in the construction of a working platform is of uniform size and strength is capable of supporting the load and number of building workers in accordance with the relevant national standards keeping in view the safety of such

		building workers with non-skid surface, board, plank or decking is fastened and secured, concrete, other debris or materials are not allowed to accumulate at any platform on a scaffold, adequate measures are taken to prevent injury which may be caused by falling material and objects by using safety nets or other suitable means.
Rule 194	Repair of damaged scaffolds	No building worker is permitted to work on a scaffold which has been damaged or weakened, necessary warning signs are displayed at such places where repairs of scaffold are undertaken.
Rule 195	Opening	Every opening or shaft in the floor is provided with suitable means to protect the fall of a person or material by providing suitable fencing or railing of height not less than 900 mm and providing suitable safety nets.
Rule 196	Guardrails	Every side of a working platform from which a person is liable to fall is provided with suitable and safe guardrails and toe board of adequate strength to prevent fall of any building worker, material or tools from such platform.
<u>Rule 197</u>	Scaffold used by building workers of different employers	Where a scaffold or a part of a scaffold is used, which has previously been used by another employer for his building workers, such scaffold or part thereof is used only after its inspection and examination by a responsible person for its use that such scaffold or part is safe and fit for such use.
Rule 198	Protection against electric power line	All necessary and practical measures for protection are taken to prevent any building worker, working on a scaffold, from coming into contact with the electric wires or dangerous equipment.
Rule 199	Screening net and wire nets	where a scaffold is erected in an area where the construction activities may pose hazards to pedestrians or vehicular traffic nearby from the falling of objects, wire nets or screening nets are used to envelope such scaffold

<p><u>Rule 200</u></p>	<p>Tower scaffold</p>	<p>The height of every tower scaffold used in building or other construction work is not more than eight times, the lesser of the base dimension of such scaffold, scaffold is lashed to a building or a fixed structure before being used by the building workers, no building worker remains on board scaffold, tools, material when it is being shifted from one position to another position.</p>
<p><u>Rule 208</u></p>	<p>Safety Committees</p>	<p>Every establishment wherein five hundred or more building workers are ordinarily employed, there shall be a Safety Committee constituted by the employer which shall be represented by equal number of representatives of employer and building workers employed in such establishment. In no case the number of representatives of the employer shall exceed the representatives of building workers.</p>
<p><u>Rule 209</u></p>	<p>Safety Officer</p>	<p>Wherever number of workers employed by single employer is less than five hundred, such employers may form a group and appoint a common safety officer for such group of employers with prior permission of Chief Inspector of Inspections of Building and Construction.</p>
<p><u>Rule 210</u></p>	<p>Reporting of accidents</p>	<p>Causes loss of life, or disables a building worker from working for a period of forty eight hours or more immediately following the accident, shall forthwith be sent by telegram, telephone, fax or similar other means including special messenger within four hours in case of fatal accidents and seventy two hours, in case of other accidents involving building worker, to-  The Assistant Labor Commissioner/  Labor Officer of the District, having jurisdiction in the area in which the establishment in which such accident or dangerous occurrence took place is located. Such Assistant Labor</p>

		<p>Commissioner/Labor Officer shall be the authority appointed under section 39 of the Act.</p> <p>Board with which the building worker involved in accident was registered as a beneficiary.</p> <p>Chief Inspector of Inspections of Building and Construction.</p>
<u>Rule 211</u>	<p>Procedure for enquiry into causes of accident or dangerous occurrence</p>	<p>Procedure for enquiry into the causes of accident or dangerous occurrence-</p> <p>(1) The enquiry under subsection (2) or sub section (3) of section 39 of the Act, as the case may be, shall be conducted by the authority referred to in sub-clause (i) of clause (b) of sub-rule (1) of rule 210, in the following manner, namely:- the enquiry shall be commenced as early as it may be, and in any case, within fifteen days of the receipt of notice of accident or dangerous occurrence under rule 210, the enquiry may be conducted by the authority referred to in sub-clause (i) of clause (b) of sub-rule 1 of rule 210 himself or by an enquiry officer appointed by such authority, A copy of the findings along with a brief statement of facts relating to an enquiry conducted under this rule shall be forwarded to the Chief Inspector of Inspections of Building and Construction and the Government by the authority referred to in sub-rule (1) of rule 210.</p>
<u>Rule 223</u>	<p>Medical examination of building workers, etc.</p>	<p>A building worker who is employed for a work involving such risk or hazards, every operator of a crane, winch or other lifting appliance, transport equipment or vehicle, inherent in such work as the Chief Inspector of Inspections of Building and construction, considers appropriate for the periodical medical examination of such worker, is medically examined at such intervals as the Chief Inspector of Inspections of Building</p>

Rule 224	Duties of construction medical officers	<p>The duties and responsibilities of such construction medical officer shall be as given below, namely:-</p> <p>(a) medical examination of building workers. (b) first-aid care including emergency medical treatment.</p> <p>(c) notification of occupational diseases to the concerned authorities in accordance with these rules;</p> <p>(d) immunization services;</p> <p>(d) medical record upkeep and</p> <p>(e) maintenance;</p> <p>(f) health education including advisory services on family planning, personal hygiene, environmental sanitation and safety.</p> <p>Referral services.</p>
<u>Rule 225</u>	Occupational health Centers	<p>An<sup>(a)</sup> occupational health center, mobile or static, is provided and maintained in good order at such sit, A construction medical officer appointed at an occupational health center possesses the qualification as laid in Schedule - XI, annexed to these rules.</p>
Rule 226	Ambulance Room	<p>Five hundred or less workers are employed at such construction site there is an ambulance room at such construction site or an arrangement with a nearby hospital for providing an ambulance room and Such ambulance room is in the charge of a qualified nurse and the service of such ambulance room is available to building worker employed at such construction site at every time when he is at work.</p>
Rule 227	Ambulance van	<p>An ambulance van is provided at such construction site or an arrangement is made with a nearby hospital for providing such ambulance van for transportation of serious cases of accident or sickness of the building workers to the hospital promptly and such</p>

		ambulance van is maintained in good repair and is equipped with standard facilities specified in Schedule V annexed to these rules.
<u>Rule 228</u>	Stretchers	Sufficient number of stretchers is provided at such construction site so as to be readily available in an emergency.
<u>Rule 231</u>	First-aid boxes	<p>Sufficient number of first aid boxes or cupboards are provided and maintained for providing first-aid to the building workers.</p> <p>(A) Every first-aid box or cupboard is distinctly marked "First-Aid" and is equipped with the articles specified in Schedule III annexed to these rules.</p> <p>(B) nothing except appliances or requisites for first-aid is kept in a first-aid box or cupboard and such box or cupboard is so kept as to protect it against contamination by dust or other foreign matter and against penetration of moisture and such box or cupboard is kept in the charge of a person trained in first-aid and is always readily available during working hours.</p>
<u>Rule 232</u>	Emergency care services or emergency treatment	<p>Ensure at a construction site of a building or other construction work that-</p> <p>(a) Essential lifesaving aides and appliances required to handle-</p> <p>(i) head injuries and spinal injuries;</p> <p>(ii) bleeding;</p> <p>(iii) fractures and dislocations of bones and joints;</p> <p>(iv) crush injuries;</p> <p>(v) shock, including electric shock;</p> <p>(vi) dehydration due to any cause;</p> <p>(vii) snake bite, insect bite, scorpion and bee stings;</p> <p>(viii) burns, including chemical burn;</p> <p>(ix) bends or divers paralysis;</p> <p>(x) other surgical, gynecological,</p>

		<p>obstetric, or pediatric emergencies;</p> <p>(xi) drowning;</p> <p>(xii) sunstroke and frost bite to building workers,Are provided and properly maintained under the supervision of a construction medical officer.</p>
Rule 234	Hours of work, intervals of rest and spread over etc.	No building worker employed in building or other construction work shall be required or allowed to work for more than nine hours a day or forty eight hours a week. Not allowed to work continuously for more than five hours unless he had an interval of rest of not less than half an hour. If work for more than nine hours on any day or for more than forty eight hours in any week, he shall, in respect of overtime work, be entitled to wages at double the ordinary rate ofwages.
<u>Rule 235</u>	Weekly rest, payment for work done on the day of rest at overtime rate,etc.	No building worker employed in building or other construction work shall be required or allowed to work on a rest day unless he already had or will have a substituted rest day for a whole day on one of the three days immediately before or after such rest day: Provided that no substitution shall be made which results in a building worker working for more than ten days consecutively without a rest day for a wholeday.
<u>Rule 236</u>	Night Shifts	A rest day for the purposes of rule 235 shall mean a period of twenty-four consecutive hours beginning from the time when such shift ends. The hours after midnight during which such building worker has worked shall be counted towards the previous day. The following day shall be deemed to be the period of twenty-fourhours beginning from the time when such shift ends.
<u>Rule 243</u>	Latrine and urinal accommodation	Every latrine shall be under cover and so partitioned off as to secure privacy, and shall have a proper door and fastenings. Every latrine or urinal shall be adequately lighted and shall be maintained in a clean and sanitary condition at all times. the

		walls, ceilings and partitions of every latrine or urinal shall be white washed or color washed once in every period of four months
Rule 244	Canteens	The canteen, referred to in sub-rule (1) shall consist of a dining hall with furniture sufficient to accommodate building workers using such canteen, a kitchen, store-room, pantry and washing places separately for building workers and for utensils. shall be sufficiently lighted at all times when any person has access to it. Inside walls of the kitchen of such canteen shall be lime- washed once in every three months. shall be situated at the distance not less than fifteen point two meters from any latrine or urinal or any source of dust, smoke or obnoxious fumes
Rule 245	Foodstuff to be served in the canteen	The foodstuffs and other items to be served in the canteen, referred to in sub-rule (1) of rule 244, shall be in conformity with the normal dietary habits of the building workers
Rule 246	Serving of tea and snacks at the work places	At a building or other construction work where a work place is situated at a distance of more than zero point two kilometers from the canteen arrangement shall be made by the employer employing building workers at such place for serving tea and light refreshment to such building workers at such place.
<u>Rule 247</u>	Charges of foodstuff	The charges for foodstuffs beverages and other items served in the canteen provided under sub-rule (1) of rule 244 shall be based on "no profit - no loss" and the price list of such items shall conspicuously displayed in such canteen

## **23. CONSENT TO WORK**

### **23.1 Purpose**

The purpose of this procedure is to ensure that a robust review of method statements and actual working practices is carried out by contractors. This procedure will also define the monitoring requirements for contractors' activities to ensure they are an integral part of the site visits undertaken by CPWD project staff.

### **23.2 Scope**

This procedure will apply to all contractors working on CPWD projects in the India.

### **23.3 Roles & Responsibilities**

Contractor's Project Manager – The PM is responsible for ensuring that the requirements of this procedure are complied with on the project. In particular the contractor PM will take all reasonable measures to ensure that the no work started without a method statement and risk assessment that has been reviewed and accepted by CPWD.

Contractor's SHE Manager – The SHE Manager is responsible to ensure suitability of the method statements and risk assessments to meet the local SHE legislative requirements.

The Contractor SHE Manager will immediately notify in the event the contractor starts work without a relevant method statement or risk assessment.

All contractor Staff – All CPWD staff on the project have a responsibility to familiarise themselves with the detail of the method statements and risk assessments for the work they are supervising/inspecting. In the event that the contractor deviates from the approved method statement, CPWD staff are expected to stop work and report the non-compliance to the SHE Manager and PM.

### **23.4 Definitions**

Method Statement – A written document providing details of how a particular activity will be carried out in terms of methodology and sequence. The method statement must include sufficient information on the health and safety arrangements for the work.

Consent To Work – A document issued for high risk work activities to ensure that the methodology proposed in the method statement can be safely followed on site. Note that for low risk work the specific requirements of the consent to work procedure do not apply.

Work Demonstration – Term used to describe the first demonstration of the contractor's work activity against the written method statement.

Method Statement Monitoring – Monitoring of the contractor's work activities to ensure that the approved method of working is strictly adhered to by the workforce. Monitoring is carried out by CPWD staff and an observation sheet is completed detailing any noncompliance, the corrective action taken and the preventative action required.

### **23.5 General Requirements**

Contractor PM will ensure that a method statement schedule is prepared for all construction activities that will be carried out on the project..

A monthly project risk review meeting should be held within the project and contractor project team to discuss forthcoming works and determine the risk rating of the activities. Work activities will be assigned a high, medium or low risk rating depending on the type of work being carried out.

The ratings are defined as follows:

High Risk – Activities where it is foreseeable that fatalities or multiple fatalities could occur. Medium Risk – Activities where it is foreseeable that serious injury accidents could occur. Low Risk – Activities where it is foreseeable that only minor injury accidents could occur.

- Once the contractor has commenced a high risk activity for the first time on the project, CPWD staff should review the work demonstration to check the work can be done safely and in accordance with the written method statement;
- For repetitive high risk work activities the contractor will photograph the work sequence and develop a picture-based work methodology to supplement the written approved method statement;
- If there is a difference between what the method statements for high risk work states and how work is carried out during the work demonstration the contractor must resolve the issues.
- Once the method statement and work demonstration are aligned then CONTRACTOR will issue a consent to work clearly stating that work is permitted to proceed in accordance with the approved method statement and work demonstration;
- Contractor SHE Manager will deliver a briefing to ensure that the health and safety requirements of each high risk work activity are clearly explained to CPWD staff who will be supervising that particular activity;

### **23.6 Withdrawal of Consent to Work**

In the event of systemic failures in the contractor's compliance with the approved method statement, CPWD will issue a formal instruction withdrawing the consent to work for the non-compliant activity;

- Following withdrawal of a consent to work the contractor will be required to prepare an action plan detailing the measures they will take to ensure that the work can be safely resumed;
- Records of method statement review and monitoring shall be maintained on the project using the 'Method Statement Non Compliance Log' sheet.

## **24. NON CONFORMANCE REPORT**

### **24.1 Purpose**

- A non-conformance report means that something has happen wrong or a deviation found in system procedures needs to be addressed and adequate corrective actions are required immediately.
- The purpose of this procedure is to make sure that a robust procedures being followed and the activities being carried out according to that.

### **24.2 Scope**

- This procedure will apply to all CPWD projects in the India Business.

### **24.3 Document**

Non-Conformance Report Non-Conformance Report Register

## **25. WASTE MANAGEMENT**

### **25.1 Design Considerations**

Where practical use design to reduce the need to cut standard size materials; Specify where possible on a 'fit for purpose' basis, thus facilitating the use of recycled materials. Examples, of goods that might be considered are; recycled aggregates, demolition materials, scrap metals, damp proof courses or membranes, wall panelling, shuttering void formers, insulation, drainage pipes, signposts.

### **25.2 Pre-construction**

Consider the possibility of making the waste producers (trade or specialist) responsible for their own waste (although also ensuring that adequate controls are in place) and make the issue of waste and its disposal a priced item.

Contractor to ensure procedures and plans are in place to ensure full legal compliance. It is good practice for site management to personally ensure that only licensed waste carriers are used and that disposal sites are licensed to take the type of waste removed from the site;

Prior to site works commencement, assess whether hazardous waste (e.g. asbestos) will be generated

by the site activities, and liaise as appropriate with the Environment Agency to ensure correct handling and disposal; The management options for the construction wastes (e.g. the technical and financial viability of resale, reuse on site or recycling) will be determined by their quantity and type. Therefore, prior to the commencement of site activities estimate waste production data (type, quantity and rate of supply) through contract documentation; consider the possibilities of co-operation with other construction sites in the vicinity as the greater the volume and reliability of waste supply, the greater is the viability of reuse and recycling; Agree a brief that includes spoil management i.e. disposal, reuse or recycling. The proposed management should be able to cope with unexpected conditions.

### **25.3 Construction**

Waste should be disposed of in accordance with the current regulations and through authorised channels (Environmental Protection (Duty of Care) Regulations 1989, Amendments 2000

segregation at source is vital for effective waste management since it makes both external and internal reuse and recycling much more viable, therefore provide waste skips for the separate waste streams expected;

Contractor to ensure that all site employees, including Associated Contractors/Agencies, are aware of the correct waste disposal procedures and the locations of the waste skips for the different waste streams;

Use information on materials ordered and consumed to establish a better understanding of the rate and locations of actual wastage.

## **26. PROTECTION OF WATER COURSES**

### **26.1 Context**

Potential for spillage may arise from a number of sources including fuels, oils, lubricants and chemicals. Early identification of potential hazards and establishing working practices to minimise risks to the aquatic environment are therefore likely to be an important feature for all sites.

Procedures are required to minimise the likelihood of spillage and, if spillage were to occur, to generate timely and appropriate response to reduce its impact.

### **26.2 Design**

Determine whether piling works will puncture any natural protection layers to any underlying aquifers, therefore increasing the risk of downward pollutant mobility; where a potential hazard to ground or surface water is identified liaise with the Environment Agency prior to starting work;.

### **26.3 Pre-construction**

Ensure legal compliance, such as the Water Resources Act 1974; Train staff in working practices to minimise the risks of water pollution;

Where appropriate, ensure Associated Contractors/Agencies s comply with procedures implemented by the Trade Contractors;

Prior to the commencement of site work conduct a site specific assessment of the potential for water pollution. The assessment would include consideration of the potential environmental damage resulting from spillage, leakage, incorrect use and disposal; as practical choose chemicals with low environmental toxicity;

### **26.4 Construction**

Where a potential risk to ground water has been identified place small plant/equipment on drip trays, or if these are temporary unavailable inspect the equipment daily for signs of leaking. Regular Staff will only be able to ensure that they are using the current version of this form / template if it is retrieved from the SHEMS at the point of use. Printed copy of this documents are uncontrolled.

Maintenance checks should be carried out to anticipate potential leakage. Drip trays must be regularly emptied, with the frequency increased as appropriate if rain is expected;

Position fuel and chemical stores such as to minimise the risks to water resources (e.g. at least 10m from the nearest water feature). All fuels and chemicals must be bundled in an area capable of holding 110% volume of the stored volumes. Taps and valves must empty within the bund; Establish early warning systems and the identification of contingency plans for spill response. where possible use mechanical alternatives to pesticides;

Establish disposal procedures for emptying fuel and chemical containers, ensuring that any residues in these containers do not pose a risk to the aquatic environment. Ensure that construction debris is not dumped in or near watercourses or drains;

Do not permit the refuelling of plant and equipment close (within 10m) to water features and when refueling by hand ensure that funnels or spouts are used;

Arrange protection to watercourses from site run-offs by means appropriate to the site. Outflows from de-watering systems may include silt, sediment and contaminated groundwater. Run-off from washing ready-mixed trucks and/or earth moving equipment or the hosing down of dirt/concrete from various surfaces is likely to have high suspended solids content. High sediment load can severely damage aquatic life. Consider the use of settling tanks or other separation methods; maintain an emergency spills containment kit on the site; if working on a remote site and no mains sewerage facilities are

available, locate on site facilities carefully to avoid aquatic pollution; seal up or remove abandoned drains to minimise the spread of contaminated water; actively manage site surface water e.g. provide collection channels leading to oil/silt interceptors; Consider whether any waste water could be reused.

## **27. EMISSION REDUCTION**

### **27.1 Pre-construction**

- Relate COSHH (Control of Substances Hazardous to Health regulation) assessments to risks to the environment in general and potential effects on neighbours;
- Identify the potential pollutants and/or irritants that will need particular attention and control (for example formaldehyde from plywood, chipboard and laminate etc. etc.);
- Make and implement plans to control airborne pollutants such as;
- Dust from earth moving and other site vehicle movements,
- Wood dust from joinery and other wood working,
- Fumes from welding,
- Sprayed formwork oils.
- Sprayed paint and/or other sealant;
- Ensure service programmes are adequate to reduce air emissions of construction plant and other site, vehicles;
- Ensure the potential noise of construction operations are assessed prior to the commencement of the works, together with an assessment of baseline conditions.
- Establish system for issuing prior notification of working outside normal hours and any particularly noisy activities. In order to minimise the impact of noise disturbance during the construction works.
- Identify particularly noise sensitive areas and implement appropriate noise control measures;
- Minimise as far as practical road transport movements of e.g. materials and therefore minimise exhaust emissions;

### **27.2 Construction**

- Consider applying water and polymer sprays to haul roads and using dust extractors on saws;
- Eliminate site fires as a form of site waste disposal;

- Secure or cover all loose material that could be made air borne by the wind, include controls for damp materials that might dry out;

## **28. PAPER SAVING**

- consider recycled paper use;
- limit distribution lists to essential readers;
- collect and use scrap waste paper for re-use as drafts, note pads;
- use electronic mail and filing systems where possible; as appropriate encourage double sided photocopying;
- For waste paper products that are produced provide adequate storage space and separate containers to ease recycling of this waste.

## **29. ENERGY CONSERVATION**

Although the energy used in buildings is much greater than in the construction process, the overall sum spent by construction firms in energy is very large and therefore means to reduce this waste should be considered such as:

Energy use in offices, lighting, equipment, heating;

Efficient use and maintenance of power tools and plant used during the construction process;  
Transportation policies (i.e. conservation of non-renewable sources of fuel)

### **29.1 Examples of Good Practice in Office/General Site Housekeeping**

where practical layout site offices such that maximum use can be made of natural lighting and ventilation, orientated offices to make maximum use of solar gain for heating and to achieve good levels of daylight; Use low energy light bulbs in the office;

Encourage staff to switch off lights and office equipment whenever not in use; Use energy efficient lighting for the site floodlights if these are required

Ensure site cabins are insulated, seal gaps around services entry, and use self-closing doors Use energy efficient point of use heaters

### **29.2 Examples of Good Practice in use of Small Tools and Construction Plant**

Develop plans and procedures to ensure equipment is turned off when not in use; Ensure equipment is well maintained;

In training/awareness modules emphasise that particularly with respect to energy consumption environmental benefits and financial benefits are concurrent to encourage participation

### **29.3 Examples of Good Practice Transportation Policy (with respect to energy consumption)**

Policies to encourage purchasing of fuel efficient, smaller engine company vehicles;

Particularly for larger civil engineering projects can more use be made of bulk materials transportation methods such as rail.

Assess the balance of size of loads and frequency of trips to maximise energy efficiency given the constraints of the project

'Bus' staff to work rather than encouraging the use of private vehicles Ensure site plant is well maintained

## **30. WATER CONSERVATION**

### **30.1 Pre-construction**

Arrange for the site water supplies to be metered, and keep records from this meter of water consumed; In training/awareness modules include the point that excessive water consumption leads to the need to make arrangements to dispose of this water legally;

### **30.2 Construction**

Establish procedures for ensuring water pipes are not left running needlessly and that any leaks are promptly repaired;

Use low water flush toilets or water-less toilets.

## **31 CONTRACTOR ASSESSMENT**

The Project Manager is responsible for ensuring assessment of the Trade Contractors' on the level of their environmental expertise and whether it is sufficient for the project specific environmental requirements.

Method statements will be required where specified in the contract/tender documentation. Issues should be addressed at the pre-start meeting and subsequent progress meetings.

## **32. WORKING AT HEIGHT**

### **32.1 General**

Working at height is the largest single cause of serious accidents in the construction industry and

therefore, a specific risk assessment shall be prepared for all work where workers or materials can fall from more than two metres.

Where work is being carried out above areas where there is public access such as roads footpaths etc. particular care must be taken to ensure that no materials can fall from the working area.

Edge protection shall be provided at all leading edges or openings where workers or materials can fall more than two metres. Edge protection shall meet the minimum standard of; a) a main guardrail at least 1 metre above the edges toe board at least 200 mm high; and an intermediate guard rail or other barrier so that there is no gap more than 470 mm.

### **32.2 Use of Scaffolds**

All scaffolds should be erected and dismantled by workmen who are thoroughly experienced in the erection and dismantling of scaffolding.

All scaffolds should be inspected by a competent person at least every three days after erection and the results of inspections recorded and the records shall be kept available for checking by the SHE management team.

"Fit to Use" tags in/with green colour shall be displayed on all scaffolds to show whether they are safe for use or not. All Safe for Use tags shall be signed by a senior site engineer from the contractor.

All scaffolds shall be constructed of sound materials free from patent defect. The following measures shall be taken;

- the scaffold shall be constructed for the correct use ( Light or Heavy Duty )

- securely fixed to existing structures or adequately buttressed;
- the use of barrels, boxes, loose tiles or other unsuitable material shall not be used as supports for working platforms;
- all working platforms shall be fully boarded;
- all working platforms shall have guard rails at one meter height and shall also have an intermediate rail at half height;
- all working platforms shall be provided with toe boards;
- all working platforms shall be kept free of unnecessary obstruction or rubbish
- secure ladder access shall be provided;
- A proper risk analysis should be on place.
- A Safe Work Method Statement that outlines the construction phasing and sequence for the scaffold for review & approval prior to any site works.
- An independent structural consultant is required to review and approve the Work Method Statement (this should identify any requirements for temporary additional bracing and structural support during scaffold erection)
- If necessary the scaffolding should be also be designed by the independent structural consultant considering the weather condition.
- Formal “CTW” (Consent to work) should be issued to the contractor only once the Work Method Statement has been approved by the independent structural consultant.
- The scaffold structure should be inspected prior to use and after any alteration / change.
- For high level scaffolds the final scaffold erection should be reviewed and approved by the Independent structural consultant.
- Permit to work should be issued to the workers every day after visual inspection.
- Red/Green tag on scaffold structure must be provided by a competent person prior to use.
- If the scaffold construction is not in accordance with the approved method statement stop works order should be issued and that the scaffold should be immediately dismantled. This process should be accompanied by a full time site supervisor to ensure that the scaffold is dismantled.

### **32.3 Use of Ladders**

All ladders shall be of sound construction and shall be free from patent defect.

Ladders should be checked weekly and defective ladders shall be promptly and properly repaired or replaced.

Ladders shall not be used as working platforms but may be used for work of short duration of up to thirty minutes.

Metal ladders shall not be used near or adjacent to overhead power lines unless they have been certified dead under a permit to work system.

Ladders shall;

- be secured at the top or footed at the bottom to prevent slippage;
- not be used if any rung is missing;
- not be used for any other purpose than to provide access;
- be set at an angle of seventy five degrees unless designed for vertical access;
- all vertical ladders shall be fitted with hoops to prevent falls;

### **32.4 Safety Harnesses / Fall Arresters**

Use of safety harnesses shall be considered wherever any work on height ( 2 meter or more) happening. Safety harnesses are used they should be of the full body double lanyard type and secure anchorage points shall be provided and used. Workers must be instructed in the proper use of harnesses.

### **References**

Building And Other Construction Workers (Regulation of Employment and Conditions of Service) Rules 2002

Chapters: XV and XIX

### **Indian Standards;**

IS 3696 (Part 1): 1987 Safety Code for Scaffolds and Ladders, Part 1, Scaffolds IS 3696 (Part 2): 1991 Safety Code for Scaffolds and Ladders, Part 2, Ladders

IS 13416 (Part 1):1992 Recommendations for preventive measures against hazards in the workplace, Part

1, falling material hazards protection

IS 13416 (Part 2):1992 Recommendations for preventive measures against hazards in the workplace, Part 2, fall protection

### **32.5 Competence**

The Contractor shall ensure that no person engages in any activity, including organization, planning and supervision, in relation to work at height or work equipment for use in such work unless he is competent to do so or, if being trained, is being supervised by a competent person

### **32.6 Selection of 'work equipment' for work at height**

The Contractor, in selecting work equipment for use in work at height, shall give collective protection measures priority over personal protection measures; and take account of:-

- the working conditions and the risks to the safety of persons at the place where the work equipment is to be used;
- in the case of work equipment for access and egress, the distance to be negotiated;
- The distance and consequences of a potential fall;
- The duration and frequency of use;
- The need for easy and timely evacuation and rescue in an emergency; and any additional risk posed by the use, installation or removal of that work equipment or by evacuation and rescue from it.

### **32.7 Requirements for collective safeguards for arresting falls**

- Collective safeguard are a safety net, airbag or other collective safeguard for arresting falls
- safeguard shall be used only if
  - (i) A risk assessment has demonstrated that the work activity can so far indentas is reasonably practicable be performed safely while using it and without affecting its effectiveness;
  - (ii) The use of other, safer work equipment is not reasonably practicable; and
  - (iii) A sufficient number of available persons have received adequate training specific to the safeguard, including rescue procedures.

A safeguard shall be suitable and of sufficient strength to arrest safely the fall of any person who is liable to fall.

## **A Safeguard shall**

- I. in the case of a safeguard which is designed to be attached, be securely attached to all the required anchors, and the anchors and the means of attachment thereto shall be suitable and of sufficient strength and stability for the purpose of safely supporting the foreseeable loading in arresting any fall and during any subsequent rescue;
- ii. in the case of an airbag, landing mat or similar safeguard, be stable; and
- iii. In the case of a safeguard, which distorts in arresting a fall, afford sufficient clearance.

Suitable and sufficient steps shall be taken to ensure, so far as practicable, that in the event of a fall by any person the safeguard does not itself cause injury to that person.

## **B. Requirements for personal fall protection systems**

A personal fall protection system shall be used only if

A risk assessment has demonstrated that:

- (i) The work can so far as is reasonably practicable be performed safely while using that system; and
- (ii) The use of other safer work equipment is not reasonably practicable; and
- (iii) The user and a sufficient number of available persons have received adequate training specific to the operations envisaged, including rescue procedures.

A personal fall protection system shall

- Be suitable and of sufficient strength for the purposes for which it is being used having regard to the work being carried out and any Foreseeable loading;
- Where necessary, fit the user;
- Be correctly fitted;
- Be designed to minimize injury to the user and, where necessary, be adjusted to prevent the user falling or slipping from it, should a fall occur; and
- Be so designed, installed and used as to prevent unplanned or uncontrolled movement of the user

A personal fall protection system designed for use with an anchor shall be securely attached to at least one anchor, and each anchor and the means of attachment thereto shall be suitable and of sufficient strength and stability for the purpose of supporting any foreseeable loading.

Suitable and sufficient steps shall be taken to prevent any person falling or slipping from a personal fall protection system.

### **33 EXCAVATIONS**

Excavation is one of the important phases of any construction activity. Due to insufficient attention to the safety aspects it frequently becomes the cause of many accidents. Therefore required to plan and execute all excavations in a safe manner.

It should be ensured that all excavations are supervised by contractor with thorough knowledge and experience of excavation work.

The integrity of the excavation and the support system shall be inspected prior to the commencement of any works on a daily basis with the results of the inspections being formally recorded. All such records shall be kept available for inspection by SHE manager.

Where there is the possibility of any ingress of water then pumping sumps shall be established with pumps being readily available for use and additional ladders placed for use in the event of an emergency evacuation.

#### **33.1 Planning**

The correct planning of excavations is essential for safety and before digging. Any excavations should be planned against the following;

- collapse of the sides;
- materials falling onto people working in the excavation;
- people and vehicles falling into the excavation;
- people being struck by plant;
- undermining near by structures;
- contact with underground services;.
- fumes; and

Make sure the necessary equipment needed such as trench sheets, props, etc, are available on site before work starts.

#### **33.2 General Precautions**

The following precautions should be observed;

- Prevent the sides and the ends from collapsing by battering them to a safe angle or supporting them with timber, sheeting or proprietary support systems.
- Do not go into unsupported excavations.
- Never work ahead of the support.
- Remember that even work in shallow trenches can be dangerous. You may need to provide support if the work involves bending or kneeling in the trench.
- Prevention of materials falling into excavations
- Do not store spoil or other materials within one meter of the sides of excavations. The spoil may fall into the excavation and the extra loading will make the sides more
- Cable detectors shall be used and trial pit shall be dug to ascertain location of underground pipes where underground pipe line drawings are not available.
- Hand digging only shall be specified to avoid cutting of cables where uncertainty of exact location of underground cables exist.
- Banks man to be provided near the bucket to warn the operator who is unable to see work area clearly when the bucket uncovers a cable tile, cable warning tape or the cable itself.
- Excavated material to be stored 1.0 m away from the excavated area. Excavation in excess of 1.2 m depth required to be shored or have sides sloped back.
- Excavation shall be barricaded and warning signs installed and during dark hours light shall be strategically positioned to prevent men and equipment from falling down.
- During rains personnel should not be allowed to work near excavation and following rains excavation shall be inspected prior to allowing people to work again.
- All excavations shall have adequate access and egress for emergency evacuation.
- Personnel are to be kept minimum at all times during the excavation.
- Personnel are not allowed to work close to the edges of excavation.
- Temporary crossing for personnel shall be provided over any trench in excess of 1.5 m in depth.  
Such crossings shall be at least 600 mm wide of adequate strength and shall have a handrail on at least one side. There shall be no more than 30 m between crossings.
- No person shall be permitted within 5 meters if plant i.e. shovel, diggers, rock breakers etc. is

working in the excavation

- Appropriate warning signs to be displayed.

Make sure the edges of the excavation are protected against falling materials. Provide toe boards where necessary.

- Wear a hard hat when working in excavations.
- Take steps to prevent people falling into excavations. If the excavation is 2 m or more deep, provide substantial barriers, e.g. guard rails and toe boards.
- Keep vehicles away from excavations wherever possible. Use brightly painted baulks or barriers where necessary.
- Where vehicles have to tip materials into excavations, use stop blocks to prevent them from over-running. Remember that the sides of the excavation may need extra support.

### **33.3 Undermining nearby structures**

The following precautions should be taken to prevent the undermining of nearby structures;

- Make sure excavations do not affect the footings of scaffolds or the foundations of nearby structures. Walls may have very shallow foundations, which can be undermined by even small trenches.
- Decide if the structure needs temporary support before digging starts. Surveys of the foundations and the advice of a structural engineer may be needed.

### **33.4 Avoiding underground services**

The following precautions should be taken to avoid underground services;

- Look around for obvious signs of underground services, e.g. valve covers or patching of the road surface.
- Use locators to trace any services. Mark the ground accordingly.
- Make sure that the person supervising excavation work has service plans and knows how to use them. Everyone carrying out the work should know about safe digging practices and emergency procedures.
- Operate a “Permit to Dig” system.

## 33.5 Miscellaneous

### General Inspection of Jobsite:

- Excavations, adjacent areas, and protective systems inspected by a competent person daily before the start of work.
- Competent person has the authority to remove employees from the excavation immediately.
- Surface encumbrances removed or supported.
- Employees protected from loose rock or soil that could pose a hazard by falling or rolling into the excavation.
- Hard hats worn by all employees.
- Spoils, materials, and equipment set back at least two feet from the edge of the excavation.
- Barriers provided at all remotely located excavations, wells, pits, shafts, etc.
- Walkways and bridges over excavations four feet or more in depth are equipped with standard guardrails and toe boards.
- Warning vests or other highly visible clothing provided and worn by all employees exposed to public vehicular traffic.
- Employees required to standing away from vehicles being loaded or unloaded.
- Warning system established and utilized when mobile equipment is operating near the edge of the excavation.
- Employees prohibited from going under suspended loads.
- Employees prohibited from working on the faces of slopes or benched excavations above other employees.

### Utilities:

- Utility companies contacted and/or utilities located.
- Exact location of utilities marked.
- Underground installations protected, supported, or removed when excavation is open.

### Means of Access and Egress:

- Lateral travel to means of egress no greater than 25 feet in excavations four feet or more in depth.

- Ladders used in excavations secured and extended three feet above the edge of the trench.
- Structural ramps used by employees designed by a competent person.
- Structural ramps used for equipment designed by a registered professional engineer (RPE)
- Ramps constructed of materials of uniform thickness, cleated together on the bottom, equipped with no-slip surface.
- Employees protected from cave-ins when entering or exiting the excavation.

#### **Wet Conditions:**

- Precautions taken to protect employees from the accumulation of water.
- Water removal equipment monitored by a competent person.
- Surface water or runoff diverted or controlled to prevent accumulation in the excavation.
- Inspections made after every rainstorm or other hazard-increasing occurrence.

#### **Hazardous Atmosphere:**

- Atmosphere within the excavation tested where there is a reasonable possibility of an oxygen deficiency, combustible or other harmful contaminant exposing employees to a hazard.
- Adequate precautions taken to protect employees from exposure to an atmosphere containing less than 19.5% oxygen and/or to other hazardous atmospheres
- Ventilation provided to prevent employee exposure to an atmosphere containing flammable gas in excess of 10% of the lower explosive limit of the gas.
- Testing conducted often to ensure that the atmosphere remains safe.
- Emergency equipment, such as breathing apparatus, safety harness and lifeline, and/or basket stretcher readily available where hazardous atmospheres could or do exist.
- Employees trained to use personal protective and other rescue equipment.
- Safety harness and lifeline used and individually attended when entering bell bottom or other deep confined excavations.

#### **References**

Building and Other Construction Workers (Regulation of Employment and Conditions of Service) Rules 2002

## Chapter: XIII Indian Standards

IS 3764: 1992 Excavation Work – Code of Safety

IS 13430: 1992 Safety during additional construction to existing buildings – Code of Practice? IS 2314: 1986 Steel Sheet Piling sections

IS 5121: 1969 Safety Code for Piling and Other Deep Foundations

### **34 LIFTING OPERATIONS**

All lifting appliances, including synchronised mobile jacks, pit jacks, mobile cranes, tower cranes, gantry cranes, launching beams and lorry mounted cranes, prior to being allowed to work on site shall have available for inspection by the Department's Representative a current Certificate of Inspection issued by a Competent Person approved by authority/SHE Manager.

All lifting appliances with a lifting capacity of more than one tonne shall, where practicable, be fitted with Automatic Safe Load Indicators and Audible Warning Devices which shall be kept in an operable condition at all times the lifting appliance is in use. Checks should be made to ensure that the Automatic Safe Load Indicator is properly calibrated and is functioning properly.

All lifting appliances shall be maintained in accordance with the manufacturer's instructions and shall be subject to a regular preventative maintenance programme.

All lifting appliances shall be inspected every six months by a third party competent person approved by authority/SHE Manager. Certificates of Inspection shall be available with the lifting appliance and a copy shall also be sent to the Departments Representative.

The operators of lifting appliances shall conduct daily inspections of their respective lifting appliances with the results of the inspections being recorded and kept available for inspection by the SHE Manager.

The Contractor shall ensure that only thoroughly trained and experienced persons aged twenty-one years and over are allowed to operate lifting appliances.

#### **34.1 Lifting Gear**

Lifting Gear includes chain slings, rope slings, or similar gear and a ring, link, hook, plate clamp, shackle, swivel or eye bolt.

All lifting gear shall be in good condition and shall be tested and certified every six months, with the Safe Working Load being stamped or clearly displayed upon it.

Records of test shall be kept available for inspection by the SHE Manager.

All lifting gear shall be visually inspected before any use and if any defects are found then it shall be removed from site or dismantled / disabled in order to ensure that it is not used in a defective state.

All lifting gear shall be properly stored and not left lying on the ground where it could be damaged or used in an unsafe manner.

### **34.2 Lifting Operations**

It should be ensure that during the course of any lifting operations the following minimum requirements being followed:

- All lifting operations shall be under the control of a competent “Lifting Supervisor” appointed by the contractor.
- Only thoroughly trained, competent and experienced crane drivers shall be allowed to operate cranes.
- Only thoroughly trained, competent and experienced slingers and riggers shall be allowed to sling loads and give directions to crane operators.
- A standard code of hand signals shall be adopted for controlling the movements of the crane and both the driver and the signaller shall be thoroughly familiar with the signals.
- The driver of the crane shall respond to signals from only the appointed signaller but shall obey the stop signal at any time no matter who gives it.
- Before commencing any lifting operations the ground conditions on which the crane is to stand shall be investigated in order to ensure that the load bearing capabilities are adequate.
- The weight of the load must be known to the crane driver and the slinger/rigger before lifting commencement. No loads are to be slewed over public areas without stopping pedestrians and vehicles first.
- No unauthorized persons are allowed into the lifting zone.
- No person is allowed to ride the hook of the crane or the loads being lifted.
- Any areas where a minimum clearance of six hundred millimetres from the rear of the slewing Kent ledge of the crane cannot be achieved and where persons could be trapped against obstacles then a fence shall be erected to prevent access.
- All crane hooks shall be fitted with an operable safety catch.
- Wherever practicable all loads shall have tag-lines attached in order to ensure that the load can

be controlled at all times.

- Provision shall be made to ensure that the lifting slings or chains can be safely removed from the loads once they have been landed.
- All lifted loads and stacked materials shall be left in a secure and stable condition at all times.
- Whenever working close to isolated overhead power-lines the lifting appliances shall be grounded to earth as a secondary precaution against accidental energisation.
- No close working to any live overhead power-lines is permitted without the operation of a strict Permit to Work system being in place.

### **34.3 References**

Building and Other Construction Workers (Regulation of Employment and Conditions of Service) Rules  
Chapter: VII

#### **Indian Standards**

IS 807 : 1976 Code of Practice for the design, manufacture and testing of cranes  
IS 7293 : 1974 Safety Code for working with Construction Machinery;

IS 13583 : 1993 Code of Practice for training of Crane Drivers Part 1 General British Standards

## **35 VEHICLE TRAFFIC MANAGEMENT**

### **35.1 General**

It should be ensured that all traffic management schemes shall be in accordance with the agreed schemes. Any vehicular shall not exceed the SPEED LIMIT of 15kmph while moving inside the site premises.

Adequate and clear warning signs shall be displayed at appropriate distances before the commencement of the site workings. In addition prior warning shall be given concerning the location of the approaching site entry and exit points.

All traffic signs, barriers, cones and lighting shall be kept maintained and clean at all times.

Site vehicles exiting the site shall observe caution at all times, if the vehicles are exiting directly onto the live carriageway then they shall be directed by an identifiable Traffic Controller.

Regular inspections of the traffic management schemes should be conducted by the Contractors in both the daytime and night time hours with the results of these inspections being recorded. These records shall be kept available for inspection by the SHE Manager.

### **35.2 Vehicle Control**

Traffic Controllers shall be available for directing vehicles that are exiting the sites directly onto the live carriageways. Any vehicles entering the sites that are required to execute reversing manoeuvres shall do so under the strict control of a trained and designated banks-man.

### **35.3 Spoil Removal**

Only well maintained and licensed vehicles shall be allowed to be used for the removal of excavated spoil from the sites.

All drivers shall be medically fit and in possession of a valid and current driving licence. No vehicles, which are overloaded, shall be allowed to leave the site.

Any vehicles leaving the sites carrying loads which are liable to produce airborne contaminants shall prior to leaving the site securely Sheet the load over in order to effectively contain any dis- persement during transportation on the public highway.

Vehicles exiting the site directly onto the live carriageway shall do so under the control of the clearly identified Traffic Controller.

Any vehicles that are required to reverse whilst on the site shall do so under the control of a trained banks- man.

Any vehicles prior to leaving the site shall have their wheels washed and any loose material removed. Any spoil that is removed from the work-sites shall be disposed of only at authorised dumping sites.

## **36 PEDESTRIAN SEGREGATION**

### **36.1 General**

The Site is required to keep safe and secure as possible at all times, this includes the erection of site perimeter Hoarding which shall also deter trespassers both adult and children alike.

The Contractor shall provide a solid two metre high securely erected fence be installed around the perimeter of the site, with agreed and guarded access and egress points for both personnel and vehicles.

At each entrance to the site the a large billboard warning all persons should be erected who enter the site that they are required to wear the appropriate Personal Protective Clothing and that no unauthorised

access is allowed.

Wherever the fence runs adjacent to the highway with no buffer-zones then the fence shall have traffic warning lights duly affixed to it.

Wherever the fence borders on pedestrian footpaths lighting shall be provided to illuminate the pedestrian routes. The positioning of the fence-line shall not reduce the width of the pedestrian footpath to less than 900 mm in order to be able to accommodate disabled persons in wheelchairs.

Site perimeter fencing shall be washed at least once a month and repainted at least annually.

The site fencing shall need to be inspected on a regular basis in order to ensure that the integrity of the fencing is maintained at all times as far as is practicable.

## **37 WORK IN CONFINED SPACES**

### **37.1 General**

The term 'confined space' has two defining features. Firstly, it is a place which is substantially (though not always entirely) enclosed and, secondly, there will be a reasonably foreseeable risk of serious injury from hazardous substances or conditions within the space or nearby.

Some confined spaces are fairly easy to identify, for example, closed tanks and sewers. Others are less obvious but may be equally dangerous, for example closed and unventilated or inadequately ventilated rooms and silos, ducts, culverts, tunnels, boreholes, bored piles, manholes, shafts, excavations, sumps, inspection pits, cofferdams, and building voids.

### **37.2 The hazards**

**The most likely hazards are as follows:**

- i. Flammable Substances and Oxygen Enrichment;
- ii. Toxic Gas, Fume or Vapour;
- iii. Oxygen deficiency;
- iv. The Ingress or Presence of Liquids;
- v. Presence of Excessive Heat,
- vi. Excessive Humidity.

### **37.3 Entry Procedures**

No work will be undertaken in Confined Spaces should be ensured unless a Permit to Work, has been

prepared and issued.

Only persons who have been thoroughly trained, experienced and are physically fit shall be allowed to work in Confined Spaces.

Persons with any of the following medical conditions shall not be allowed to work in confined spaces:

- i. A history of fits, blackouts or fainting attacks,
- ii. A history of heart disease or disorder,
- iii. High blood pressure,
- iv. Asthma bronchitis, or shortness of breath on exertion,
- v. Deafness
- vi. Involving giddiness or loss of balance disease,
- vii. Claustrophobia or nervous or mental disorder,
- viii. Back pain or joint trouble that would limit mobility in confined spaces,
- ix. Deformity or disease of the lower limbs limiting movement.
- x. Chronic skin disease,
- xi. Serious defects in eye sight or lack of sense of smell

No smoking shall be allowed in or within 2 meters of the opening to any confined space and suitable warning signs shall be positioned.

Before any confined space work commences the following equipment shall be available for use:

- xii. Multi Gas Monitor; or other suitable gas monitoring equipment.
- xiii. Sufficient sets of Self Contained Breathing Apparatus to enable rescue to be carried out;
- xiv. Full Body Type Harness for each worker;
- xv. Tripod and Lifeline Hoist Rope; for work in situations where a vertical exit from the confined space is required.
- xvi. Flame-proof lighting. (Hand lamps not more than 24 volts.);
- xvii. Resuscitation Equipment;

xviii. Ventilation Equipment.

The persons involved in the confined space working operations shall need to be thoroughly trained and certified as being competent in the use of the above detailed item of equipment.

## **References**

Building and Other Construction Workers (Regulation of Employment and Conditions of Service) Rules 2002

Chapter: XIII Indian Standards

IS 11972: 1987 Code of Practice for safety precautions to be taken when entering a sewerage system

## **38 SITE ELECTRICITY**

The Contractor shall nominate a representative whose name and qualifications shall be submitted in writing to the SHE Manager for review not later than 4 weeks before the appointment and who shall be solely responsible for ensuring the safety of all temporary electrical equipment on Site. The Contractor shall not install or operate any temporary Site electrical systems until this representative is appointed and has commenced duties.

The name and contact telephone number of the representative having been reviewed without objection by the SHE Manager shall be displayed at the main distribution board and several location for the temporary electrical supply so that he can be contacted in case of an emergency.

The Contractor shall submit schematic diagrams and the details of the equipment for all temporary electrical installations, and these diagrams together with the temporary electrical equipment shall be submitted to the SHE Manager for review.

All electrical installation work on Site shall be carried out in accordance with the requirements laid down in the Specification. All work shall be supervised or executed by qualified and suitably categorized electricians.

All Temporary Electrical Site installations and distribution systems shall as a minimum meet IP44 standards and be in accordance with:-

Indian Electrical Regulations; 1956 The Power Companies' Supply Rules;

### **38.1 Design Considerations**

Distribution equipment utilized within the temporary electrical distribution system shall incorporate the following features:-

- i. Flexibility in application for repeated use;
- ii. Suitability for transport and storage;
- iii. Robust construction to resist moisture and damage; and

### **38.2 Safety in use.**

All cabling shall be run at high level whenever possible and firmly secured to ensure it does not present a hazard or obstruction to people and equipment.

The installation on Site shall allow convenient access to authorized and competent operatives to work on the apparatus contained within.

### **38.3 Distribution of supply**

The Site mains voltage shall be as the Electricity Utility supplies, 415V 3-phase 4-wire system. Single-phase voltage shall be as the Electricity Utility supplies, 240V supply.

Reduced voltages shall conform to BS 7375.

The following voltages shall be adhered to for typical applications throughout the distribution systems:  
Fixed plant - 415V 3 phase;

Movable plant fed by trailing cable - 415V 3 phase;

Installations in Site buildings - 240V 1 phase; Fixed flood lighting - 240V 1 phase;

Portable and hand held tools - 110V 1 phase;

Site lighting (other than flood lighting) - 110V 1 phase; and Portable hand-lamps (general use) - 110V 1 phase.

When the low voltage supply is energized via the transformer, any power utilized from that source shall be either 415V 3 phase or / 240V. 1 phase as appropriate. The Contractor shall carry out any conversion that may be necessary to enable him to use power from that source.

Protection shall be provided for all main and sub-circuits against excess current, residual current and earth faults. The protective devices shall be capable of interrupting (without damage to any equipment or the mains or sub-circuits) any short circuit current that may occur.

Earthing and bonding shall be provided for all electrical installations and equipment to prevent the possibility of dangerous voltage rises and to ensure that faults are rapidly cleared by installed circuit protection.

Only plugs and fittings of the weatherproof type shall be used and they should be colour coded in accordance with the internationally recognised standards for example as detailed as follows:

110 volts Yellow.

240 volts Blue.

415 volts Red.

### **38.4 Cables**

Cables shall be selected after full consideration of the conditions to which they will be exposed and the duties for which they are required. For supply cables up to 3.3kV the cable armouring shall be used as the earth return in conditions where the cable is continuously extended and not subject to continuous movement after installation.

For supplies to mobile or transportable equipment where operation of the equipment subjects the cable to flexing, the cable shall conform to one of the following specifications appropriate to the duties imposed on it:

BS 6708 flexible cables for use at mines and quarries;

BS 6007 rubber insulated cables for electric power and lighting; and BS 6500 insulated flexible cords and cables.

### **38.5 Maintenance**

Strict maintenance and weekly checks of control apparatus and wiring distribution systems shall be carried out by an electrician (duly qualified to carry out the said checks) to ensure safe and efficient operation of the systems. The Contractor shall submit for review by the SHE Manager details of his maintenance schedule and maintenance works record.

All portable electrical appliances shall be permanently numbered (scarf tag labels or similar) and a record kept of the date of issue, date of the last inspection carried out and the recommended inspection period.

#### References

Building And Other Construction Workers (Regulation of Employment and Conditions of Service) Rules 2002

## **39 WELDING AND CUTTING**

### **39.1 General**

All welding, cutting and grinding is to be carried out in safe manner so that the risks are kept at a minimum. There will be some circumstances when Permits to Work will need to be issued, such as:

### **39.2 Working in tunnels;**

Welding over areas where others are working;

Working in areas with increased fire risks or hazardous environments;

All equipment must be in good condition, properly installed and routinely inspected by a competent person, and records must be kept available for inspection by the SHE Manager.

Flexible hoses, cables and connections must be free from damage or risk of damage in service. Cables and hoses shall have adequate carrying capacity.

Welders shall wear the correct personal protective equipment which includes the following; Face and eye protection with correct grade of shield;

- i. Gauntlet gloves;
- ii. Safety footwear
- iii. Welder's apron or fire retardant overalls;

The atmosphere in the vicinity of work must be known to be safe to breathe and free from flammable gases.

Adequate ventilation and fume extraction must be provided and used as required by the risk assessment and especially in enclosed areas and pits.

Surfaces to be heated by the process must be cleaned of contaminants that may be degraded by heat or give off noxious fumes (e.g. paints, plastics, zinc coating).

Naked flames or high temperature surfaces must not be allowed in the vicinity of volatile solvents.

All moveable flammable materials must be removed from the vicinity of work and fireproof covers placed over all flammable materials that cannot be removed.

During all welding the work piece and any access equipment must be safely secured.

### **39.3 Oxy-fuel Gas Processes**

Handle cylinders carefully, keep outside enclosed areas and secure in an upright position. Keep oxygen cylinders away from fuel gas cylinders where possible.

Flash back arresters shall be fitted to both the fuel gas and oxygen cylinders; Non return valves shall be fitted to the torch or cutting torch;

Ensure screwed fittings and hoses are correct and keep screwed and sealed surfaces free of contaminants, such as oil and grease.

Close cylinder valves when flame is extinguished.

Ensure any vessel, drum or tank that has contained flammable or toxic substances has been properly cleaned and inspected before subjecting it to hot work.

Checks for gas leaks should be carried out using soapy water. Remove all torches from enclosed areas when not in use.

Suitable fire extinguisher to be available at all places where hot work is being carried out.

Use firewatchers if there is a possibility of ignition unobserved by the operator (e.g. on the other side of bulkheads)

### **39.4 Arc Cutting, Gouging and Welding Processes**

Connect the welding current return cable to the work piece close to the arc point or to a well electrically conductive support structure in good contact with the work piece. Also, connect the work piece or the support structure to a separate earth terminal.

Take precautions against the risk of increased fume hazards when welding with chrome containing fluxed consumables or high current metal inert gas (MIG) or tungsten inert gas (TIG) processes.

Avoid being in contact with water or wet floors when welding. Use duckboards or rubber protection. Provide screens to limit exposure of others to glare from arcs.

Use the correct eye and face protection with the correct filter glass.

Use a low voltage open circuit relay device if welding with alternating current in constricted or damp places.

### **39.5 References Indian Standards.**

IS 818: 1961 Code of Practice for safety and health requirements in electric, gas welding and cutting operations.

IS 1179: 1967 Specification for equipment for eye and face protection during welding

IS 5983: 1967 Specification for protective filters for welding, cutting and similar operations.

IS 13416 (Part 5): 1994 Preventative measures against hazards at workplaces- Recommendation Part 5  
Fire protection

## **40 MACHINERY**

### **40.1 Machine and general area guarding**

The contractor shall ensure at the construction site all motors, cogwheels, chains and friction gearing, flywheels, shafting, dangerous and moving parts of machinery are securely fenced or legged. The fencing of dangerous part of machinery is not removed while such machinery is in motion or in use

### **40.2 Construction machinery**

Construction machineries may include dumpers and dump trucks, lift trucks and telescopic handlers piling rigs, vibro hammers, rail welding equipment's, mobile elevating work platforms, cranes, tipper lorries, lorry loaders, skip wagons, crawler tractors, scrapers, locomotives, tankers and bowsers, trailers, hydraulic and mechanical breakers etc.

### **40.3 General operating procedures**

- i. Drivers entering site shall be instructed to follow the safe system of work adopted on site. These shall be verbal instructions or, preferably, written instructions showing the relevant site rules, the site layout, delivery areas, speed limits, etc.
- ii. No passengers shall be carried, unless specific seating has been provided in accordance with the manufacturer's recommendations.
- iii. Working on gradients beyond any equipment's capability shall not be allowed.
- iv. Prevention of dumper and dump truck accidents should be managed by providing wheel stops at a sufficient distance from the edges of excavations, spoil heaps, pits, etc.
- v. If a tractor dozer is employed on clearing scrub or felling trees, it shall be provided with adequate driver protection.
- vi. When two or more scrapers are working on the same job, a minimum distance of at least 25m shall be kept between them.
- vii. In case of hydraulic breakers, hydraulic rams and hoses shall be in good working condition

#### **40.4 Safe Worthiness certificate**

Every such certificate shall have the date of purchase, main overhauling Undertaken in the past, any accident to the equipment, visual examination details, critical components safety check, list of safety devises and its working condition, manufacturer's maintenance checklist, past projects wherein the equipment's were used etc. as its minimum content.

#### **41 HEAVY PLANT OPERATIONS**

The contractor shall ensure that only safe and well-maintained plant and equipment shall be allowed to operate on any of the sites.

All operators of heavy plant such as, earth movers, piling rigs, etc. shall be medically fit, over eighteen years of age and be thoroughly trained and experienced to operate the equipment.

No un-authorized person shall be permitted to ride on plant.

The operators shall conduct daily inspections of their respective items of plant with the results of these inspections being recorded and the records kept available for inspection by the SHE Manager.

All mobile heavy plant shall be equipped with at least one 5kg Dry Powder Fire Extinguisher, carried at a suitable position so as to ensure its easy availability.

Whenever heavy plant is operating in congested areas, thoroughly trained and experienced banks men shall be deployed to control the plant and personnel movement and interface.

Any waste engine oil and filters following any on site servicing and maintenance shall be removed from the sites and disposed of in an environmentally conscious manner at authorised disposal locations.

All drums of fuel oil shall be stored on drip trays or the fuel shall be kept in bunded bulk storage fuel tanks, with quantities stored being kept to a minimum.

The storage areas shall have dry powder fire extinguishers positioned in close proximity to their location for use in an emergency. References

Building and Other Construction Workers (Regulation of Employment and Conditions of Service) Rules 2002

Chapter: X Indian Standards

IS 7293: 1974 Safety Code for Working with Construction Machinery

IS 2190: 1979 Code of Practice for the selection, installation and maintenance of portable first aid fire extinguishers.

## **42 TUNNELLING OPERATIONS**

### **42.1 Procedures**

The Contractor shall develop safety procedures and methods of working to be adopted during the course of tunnelling operations. These procedures shall include but not be limited to;

- i. Shafts and Tunnels Entry Procedure. (Including visitors.)
- ii. Blasting operations.
- iii. Atmosphere Monitoring.( Oxygen Levels, Explosive Gases, Carbon Monoxide, Hydrogen Sulphide, Oxides of Nitrogen, temperature , humidity, dust etc.
- iv. Portal Gantry Crane Operating Procedures.
- v. Emergency Preparedness Plan for the Shaft and Tunnels.
- vi. Work Train Operating Procedure.
- vii. Tunnel Boring Machine Cutter Head Chamber Entry procedure.

A detailed method statement must be produced by the Contractor, and approved by the Department's Representative before the commencement of any tunnelling operations.

### **42.2 Sanitation and Drinking Water**

Unless the worksite is within 500 metres of the portal of the tunnel, sanitation facilities shall be provided. Suitable toilets shall be provided on the scale of one unit for every 50 men on the shift. Toilets shall be effectively and regularly cleaned and disinfectants provided.

At least 5 litres of clean drinking water shall be provided per person employed on the shift. The water shall be sited near the portal and also inside tunnels over 500 metres in length. The water shall be contained in a clean container with a tight fitting lid.

Washing and cleaning facilities shall be provided for all workers near the portal.

### **42.3 Lighting**

The Contractor shall provide adequate lighting at the face and at any other point where work is in progress. A minimum of 50 lux shall be provided at the face, walkways and similar work areas. When mucking is done by tipping wagons running on trolley tracks a minimum of 30 lux shall be maintained. In all other areas the level of lighting shall not be less than 10 lux.

Emergency lighting shall be installed at the working faces and at 100m intervals along the tunnel to help escape workmen in case of accidents.

### **42.4 Ventilation**

The Contractor shall make provision for adequate ventilation of all shafts and tunnels. The ventilation shall be sufficient to ensure proper dispersal of any dust or fume.

### **42.5 Protection against Fire**

As far as practicable, combustible materials shall not be used in the construction of any room or recess containing electrical apparatus.

No flammable material shall be stored in any part of the tunnel unless it is contained in suitable flameproof containers.

An adequate supply of suitable first aid firefighting equipment shall be kept at convenient locations throughout the tunnel. This equipment shall be tested at least once a month and records kept available for inspection by the Department's Representative.

### **42.6 Warning Signals**

The contractor shall install a suitable system of warning signals for the movement of plant and materials within shafts and tunnels.

The system shall be checked daily immediately prior to the commencement of tunnelling work under the supervision of a responsible person.

The Contractor shall make detailed emergency warning signals for cases of fire, tunnel collapse etc.  
References

Building And Other Construction Workers (Regulation of Employment and Conditions of Service) Rules 2002 Chapter: XIII

### **Indian Standards**

IS 4756 : 1978 Safety Code for Tunnelling Work.

IS 2190 : 1979 Code of Practice for the selection, installation and maintenance of portable first aid fire extinguishers.

## **43 DEMOLITION**

### **43.1 General**

The Contractor shall ensure that all demolition works shall be carried out in a controlled manner under the management of experienced and competent supervision.

Prior to any demolition commencing, a survey shall be conducted to identify if there are any hazardous materials present, for example the presence of materials such as asbestos and lead.

If any hazardous materials are found, then consideration shall be given as to whether they shall need to be removed by a Specialist Agency or Associated Contractors/Agencies prior to the main demolition works commencing.

Before the demolition commences all relevant notifications will need to be given to the local authorities.

Measures for protection to the public shall be required to be put into place in order to give protection from any possible falling debris and dust generation.

All power supplies and services shall be disconnected before any demolition work commences.

## **44 FORMWORK**

### **44.1 General**

The contractor shall ensure that all formwork has been properly designed and is suitable for the purpose. All designed formwork shall be erected in strict accordance to the design.

Prior to the loading and subsequent striking of falsework / formwork, permission shall be obtained from the Contractor's Designer and Engineer who shall both inspect and sign off on the structure in person.

Adequate provision shall be made on the working platforms for the concrete placement operations, these shall include locations for vibrators and the unobstructed movement of personnel controlling the rubber

hose during the concrete pumping operations or the concrete skip during any skipping operations.

The Contractor should use the following checklist to check that falsework / formwork is being used safely;

- (a) Have the design and the supports for shuttering and falsework / formwork been checked?
- (b) Is it being erected safely from steps or proper platforms?
- (c) Are the props plumb and properly set out?
- (d) Are the bases and ground conditions adequate for the loads?

Are the correct pins used in the props?

- (f) Are the timbers in good condition?
- (g) Is it inspected by a competent person against the agreed design before permission is given to pour concrete?

## References

Building And Other Construction Workers (Regulation of Employment and Conditions of Service) Rules 2002

## 45 WORK ADJACENT TO LIVE ROADWAYS

### 45.1 General

Whenever working adjacent to any live roadways then the following aspects shall be considered.

- i. Close liaison with the Police and Municipal Authorities.
- ii. Production of an agreed traffic management scheme in accordance with the local traffic laws. (Barriers, signs, lights and road markings.) This shall include adequate provision for pedestrians.
- iii. The provision and wearing of high visibility clothing by all personnel engaged in the activities.
- iv. Traffic Marshals shall be appointed and deployed to ensure that all road movement is carried out safely.

### 45.2 Barricade

It is the responsibility of contractor to provide the barricade for

- I. Full height fence, barriers, barricades etc. shall be erected around the site in order to prevent the working area from the risk of accidents due to speedy vehicular movement. Same the way barricades protect the road users from the danger due to construction equipment and other temporary structures.

- ii. All barricades shall be conspicuously seen in the dark/night time by the road users so that no vehicle hits the barricade. Conspicuity shall be ensured by affixing retro reflective stripes of required size and shape at appropriate angle at the bottom and middle portion of the barricade at a minimum gap of 1000mm. In addition minimum one red light or red light blinker should be placed at the top of each barricade.
- iii. The structure dimension of the barricade, material and composition, its colour scheme, Department's logo and other details shall be in accordance with specifications laid down in tender document.
- iv. All barricades shall be erected as per the design requirements of the Department, numbered, painted and maintained in good condition.
- v. All openings, pedestrian pathways, holes, excavated areas, material stacking, any critical work or where it is possible to hit by any work should be provided with protective barricade.

#### **46 PERSONAL PROTECTIVE EQUIPMENT**

As a minimum dress code all Personnel shall be required to wear hard hat, safety footwear and Fluorescent jacket at construction sites. This shall be emphasized during the site induction training.

Personnel not having appropriate PPE will not be permitted to work on site. Where there is need for additional personal protective equipment, safety spectacles, hearing protection etc, based on hazard risk assessments, the user shall get it issued from store before moving to site.

Contractor shall be responsible for ensuring that suitable & as per Indian standard PPE is available, in serviceable condition and that it is used at the required times.'

<b>Safety helmet color codes</b>	
White	Department, PMC Staff
Grey	All designers and architect
Violet	Main contractors(Engineers/supervisor)
Blue	All Associated Contractors/Agencies s (engineers and supervisors)
Red	Electricians (Both contractors and Sub- Contractors)
green	Safety Professionals (Both contractors and Sub- contractors)
Orange	Security Guards and Traffic marshals
yellow	All workmen
White(visitor sticker)	Visitors

### **46.1 Head Protection**

All personnel shall be issued with safety helmets, which shall be worn at all times when in construction environment. Safety helmets shall be checked periodically for signs of wear and in particular for cracks in the shell and damage to the hammock. Any evidence of such shall result in the helmet being discarded and replacement issued.

### **46.2 Hand Protection**

Workers employed on bar bending, mixing asphalt materials, cement, lime mortar and concrete shall be provided with water protective footwear (Gum boots) and protective gloves. Appropriate gloves shall be worn at all times by all personnel involved in works where hands are exposed to harmful substances, cuts, abrasions, punctures, chemical burns or harmful temperature extremes.

### **46.3 Foot Protection**

Suitable hard toe foot wear shall be worn at all times by all personnel considering the nature of works and danger of foot injuries due to falling objects, rolling objects, object piercing the sole or when employees foot are exposed to electrical hazards.

### **46.4 Ear Protection**

Ear protection shall be worn by personnel involved in areas of high noise level or when working with equipments that generate high noise. Whenever practicable, equipment generating high noise shall be located at the maximum possible distance from any work being performed. Sound reducing boxes shall also be fitted to the equipment wherever practicable.

### **46.5 Eye Protection**

Safety glasses with rigid side shields shall be worn at all in areas where eye hazards exist due to flying particle, high speed flying particles, dust ingress, chemical splash, radiation glare, hot sparks or metal spatter or harmful vapors. Face shields shall be worn in conjunction with safety glasses when grinding, chipping, and jack hammering.

### **46.6 Respiratory Protection**

Respiratory equipment, weather stand bottled-type or self-contained breathing apparatus shall only be worn by trained and qualified personnel. Those engaged in mixing or stocking cement bags or any materials that are injurious to eyes and lung shall be provided with protective goggles and masks.

### **46.7 Fall Protection**

All personnel shall comply with the usage of full body safety harness, which states that anytime

employees working from an unprotected elevation of 1.8 m or more, fall protection must be used. Additional safety measures like providing fall arrestor type and safety net shall be provided depending upon the site conditions and job requirements.

#### **46.8 Face Protection**

Face shield is required when there is a possibility of materials penetrating the skin area of the face, specifically in grinding operation and abrasive blast cleaning operations.

- i. The contractor shall at all-time maintain a minimum of 10% spare PPEs and safety appliances and properly record and show to the Department during the inspections. Failing to do so shall invite appropriate penalty as per the provisions of the contract.
- ii. It is always the duty of the contractor to provide required PPEs for all visitors. Towards this required quantity of PPEs shall be kept always at the security post.
- iii. The PPEs and safety appliances provided by the contractor shall be of the standard as prescribed by Bureau of Indian Standards (BIS). If materials conforming to BIS standards are not available, the contractor as approved by the Department shall procure PPE and safety appliances.

#### **Eye and face protection**

Glasses with side shields /Goggles

Perform works that may injury the eyes, such as Sawing, cutting, chipping, and/or grinding

#### **Electric welding shields**

Performing or assisting in cutting and welding operations.

#### **Oxy goggles**

Performing or assisting in cutting and welding operations using oxygen and acetylene.

#### **Hand protection**

Gloves (Disposal latex, Disposable nitrile, Leather, Insulated etc.)

Exposed to hazards such as defatting material, items or material which may cause laceration, abrasions, punctures or chemical burns, or vibration from equipment such as power hand tools.

#### **Fall protection**

Full body harness with double lanyard

A full body harness and 2 shock absorbing lanyard systems shall be worn and secured where there is a

fall exposure of 2 meter or more.

## **Respiratory protection**

### Respiratory Equipment

Full-face air purifying respirator with organic vapour cartridges. To use a respirator, employees must be trained, fit tested and medically qualified.

## **47 FIRE PRECAUTIONS**

### **47.1 General**

The Contractor shall be responsible for supplying and maintaining adequate fire precaution facilities on all his sites. The following minimum standards should be adhered to.

The Contractor shall ensure that specially trained personnel are available to deal with fires due to electrical causes, gas explosions etc.

A good standard of housekeeping shall be maintained at all times on the sites. No accumulations of rubbish shall be allowed to gather.

Combustible scrap and other construction debris should be disposed off site on a regular basis. If scrap is to be burnt on site, the burning site should be specified and located at a distance no less than 12 metres from any construction work or any other combustible material.

Signage shall be erected at prominent positions showing the correct use of portable first aid fire extinguishers.

Emergency plans and Fire Evacuation plans shall be prepared and issued. Mock drills should be held on a regular basis to ensure the effectiveness of the arrangements.

### **47.2 Fire Fighting Equipment**

At various locations around the site clearly visible fire points shall be established for use in an emergency and each fire point should have available as a minimum the following type of equipment:

- i. Dry Powder Extinguisher.
- ii. Water Type Extinguisher.
- iii. Bucket of Sand.

Recharging of fire extinguishers and their proper maintenance should be ensured and as a minimum should meet Indian National Standards

Water supply for firefighting purposes should be provided at the construction site. This may be in the form of static water tank of adequate capacity or a hydrant line with adequate water pressure at outlet points.

Sufficient number of fire hoses with branch pipes should be provided at site so that the fire can be controlled until the arrival of the Fire Brigade.

The contractor shall need to give consideration to the provision of adequate firefighting arrangements within the underground and tunnelling operations including the provision of Fire Service compatible hose connections and emergency lighting

The Telephone Number of the local fire brigade should be prominently displayed near each telephone on site.

Supervisors and workmen at the site should be trained in the use of firefighting equipment provided at the site.

### **47.3 Storage of Flammable Liquids**

All flammable liquids shall be kept in a secure fire resistant store protected from electrical sparks welding sparks open flames and smoking.

Only such amounts of flammable liquids should be issued as are required for immediate use. Cans for carrying flammable liquids should be leak-proof and properly stoppered and clearly marked

#### **“FLAMMABLE LIQUID”.**

Rags soaked in paints, kerosene and other flammable liquids should be disposed of daily under supervision. Large quantities of such rags should not be allowed to accumulate.

All Diesel fuel storage tanks shall be bunded around in order to control any spillage or leakage that may occur.

“NO SMOKING” signs shall be prominently displayed at all areas where flammable materials are stored. Building And Other Construction Workers (Regulation of Employment and Conditions of Service)

Rules 2002 Chapter VI Indian Standards

IS 13416 (Part 5) : 1994 Preventative measures against hazards at workplaces Recommendations Part 5 Fire Protection

IS 1646 : 1982 Code of Practice for fire safety of buildings (general) : Electrical Installations

IS 2190 : 1979 Code of practice for selection installation and maintenance of portable first aid fire

extinguishers

IS 12349 : 1988 Fire Protection – Safety Signs

Also Part IV of National Building Code of India : 1983

## **48 SITE PERIMETER HOARDING**

### **48.1 General**

The Site is required to keep safe and secure as possible at all times, this includes the erection of site perimeter Hoarding which shall also deter trespassers both adult and children alike.

The Contractor shall provide a solid two metre high securely erected fence be installed around the perimeter of the site, with agreed and guarded access and egress points for both personnel and vehicles.

At each entrance to the site the a large billboard warning all persons should be erected who enter the site that they are required to wear the appropriate Personal Protective Clothing and that no unauthorised access is allowed.

Wherever the fence runs adjacent to the highway with no buffer-zones then the fence shall have traffic warning lights duly affixed to it.

Wherever the fence borders on pedestrian footpaths lighting shall be provided to illuminate the pedestrian routes. The positioning of the fence-line shall not reduce the width of the pedestrian footpath to less than 900 mm in order to be able to accommodate disabled persons in wheelchairs.

Site perimeter fencing shall be washed at least once a month and repainted at least annually.

The site fencing shall need to be inspected on a regular basis in order to ensure that the integrity of the fencing is maintained at all times as far as is practicable.

### **48.2 References Indian Standards**

IS 13430:1992 Safety during additional construction and alteration to existing building-code of practice.

IS 9457 Standard for colours of safety sign

## **49 TRAFFIC MANAGEMENT**

The contractor shall ensure that all traffic management schemes shall be in accordance with the agreed schemes following consultation with the Local Traffic Police and the Metropolitan and other Authorities in charge of the area.

Adequate and clear warning signs shall be displayed at appropriate distances before the

commencement of the site workings. In addition prior warning shall be given concerning the location of the approaching site entry and exit points.

All traffic signs, barriers, cones and lighting shall be kept maintained and clean at all times.

Site vehicles exiting the site shall observe caution at all times, if the vehicles are exiting directly onto the live carriageway then they shall be directed by an identifiable Traffic Controller.

Regular inspections of the traffic management schemes shall be conducted by the Contractors in both the daytime and night time hours with the results of these inspections being recorded. These records shall be kept available for inspection by the Department's Representative.

## **50 VISITORS TO SITE**

No visitor is allowed to enter the site without the permission of the Department. All authorized visitors should report at the site office. Contractor shall provide visitor's helmet (White helmet with visitor sticker) and other PPEs like Safety Shoe, reflective jacket, respiratory protection etc. as per requirement of the site.

All Visitors shall be accompanied at all times by a responsible member of the site personnel. The Contractor shall be fully responsible for all visitors' safety and health within the site.

For specific activities, additional personal protective equipment is required, Contractor shall be responsible for providing, maintaining, instructing and supervising employees in the use of any protective equipment listed and agreed as below.

## **51 SAFETY MEETING AND SELF INSPECTION**

- On all CPWD construction sites, regular site Health & Safety meetings shall be held. The frequency can vary, but shall normally be once per month.
- The site management and all contractors shall be represented at the meeting. The named PM of contractor has the coordinating safety responsibility and shall chair the meetings and write the minutes from the meetings.
- The CPWD Construction Project Manager is not obliged to attend all safety meetings.
- The minutes from the safety meetings shall be sent to the CPWD Construction Project Manager, and shall be available for review.
- The minutes from the safety meeting shall be discussed at general site meetings.
- Regular planned inspections shall be undertaken. Supervisors shall continuously monitor Safety on the site as an integral part of their line responsibility. Any substandard practices and

conditions noted during the inspection shall be recorded on the inspection report appended to the plan.

As part of the project's Environmental, Health and Safety culture planned environmental, health and safety tours shall be undertaken by senior management on a routine basis. These Health and Safety tours are designed to be a highly visible walk about by site management with the aim of demonstrating management commitment to its Environmental, Health and Safety policy. During these tours, senior management shall encourage feedback from the workforce and identify the actions necessary to improve the project's health and safety performance. Any substandard practices and conditions noted during the tour shall be reported on the "SHE walk about report".

By Project Manager	Monthly
By work Supervisor	Daily
Plant and Equipment Manager	Twice Per Month
Plant and Equipment Supervisor	Four Per Month
By SHE Officer	Daily/Weekly/Monthly (Depending on type of inspection)

Where problems are identified these will be entered on the appropriate Daily Observation Report and action will be taken to rectify the problem in accordance with the hazard / priority classification system

Class A	Major Hazard	Attend Now (Immediate action before proceeding for work)
Class B	Serious Hazard	Attend Today (Within 24 hours)
Class C	Minor Hazard	Attend within 48 hours.

## 52 LADDER SAFETY

- Inspect before use for physical defects.
- Ladders are not to be painted except for numbering purposes.
- Do not use ladders for skids, braces, workbenches, or any purpose other than climbing.
- When you are ascending or descending a ladder, do not carry objects that will

- Prevent you from grasping the ladder with both hands.
- Always face the ladder when ascending and descending.
- If you must place a ladder over a doorway, barricade the door to prevent its use and post a warning sign.
- Only one person is allowed on a ladder at a time.
- Do not jump from a ladder when descending.
- All joints between steps, rungs, and side rails must be tight.
- Safety feet must be in good working order and in place.
- Rungs must be free of grease and/or oil.

### 52.1 Stepladders

- Do not place tools or materials on the steps or platform of a stepladder
- Do not use the top two steps of a stepladder as a step or stand.
- Always level all four feet and lock spreaders in place.
- Do not use a stepladder as a straightladder.

### 52.2 Straight type or extension ladders

- All straight or extension ladders must extend at least three feet beyond the supporting object when used as an access to an elevated work area.
- After raising the extension portion of a two or more stage ladder to the desired height, check to ensure that the safety dogs or latches are engaged.
- All extension or straight ladders must be secured or tied off at the top.
- All ladders must be equipped with safety (non-skid) feet.

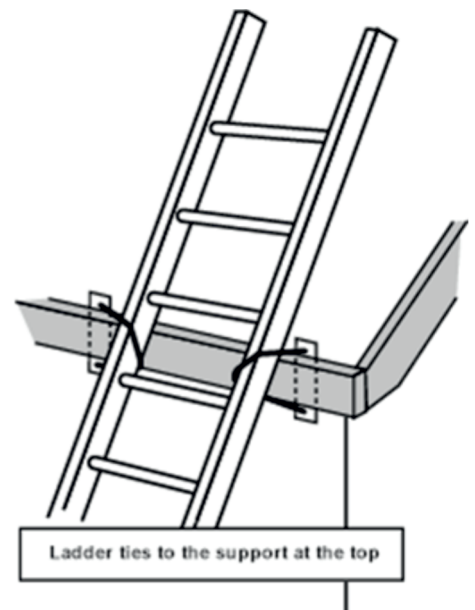
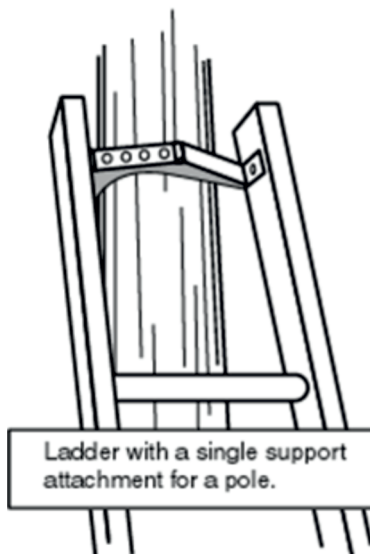

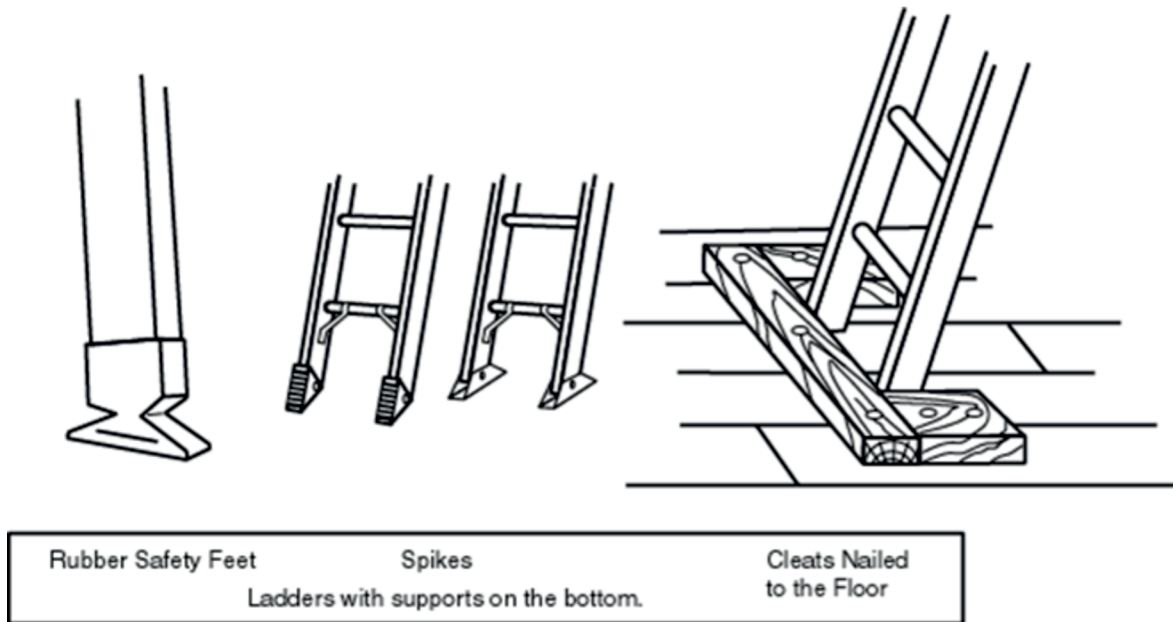

Portable ladders must be used at such a pitch that the horizontal distance from the top support to the foot of the ladder is about one-quarter of the working length of the ladder.

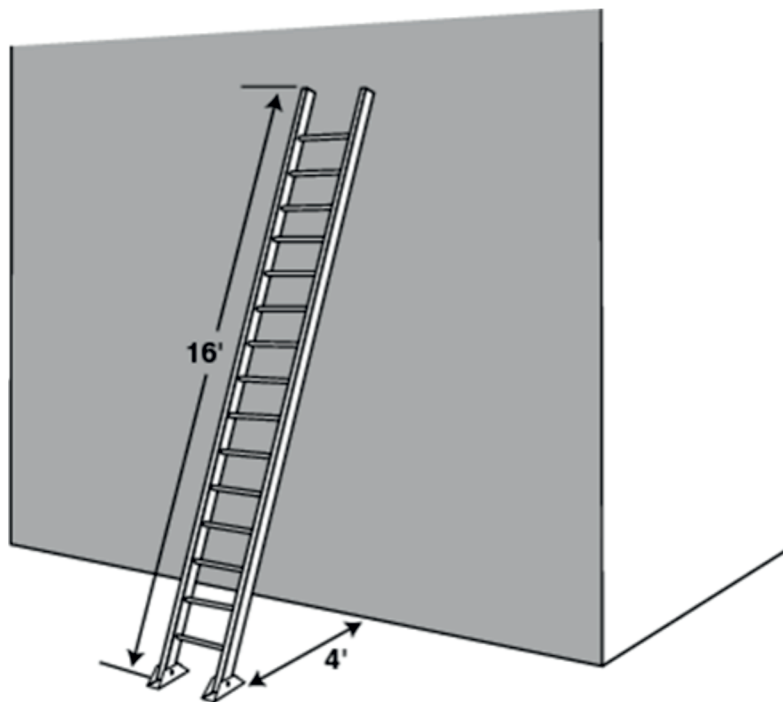

### 53 HOUSEKEEPING

Good housekeeping is an important element of accident prevention. It should be planned at the beginning of the job and carefully supervised until the final clean-up while handing over the site to the customer.

- It is recommended to have a regular clean-up in all our job sites. However

Housekeeping should be the concern of all the supervisors and Engineers in their area or working and not left from the clean-up crew. In any case, housekeeping should be a part of daily routine with clean-up being continuous procedure.

#### **a. Simple rules for housekeeping**

##### **Storage area:**

All materials should be maintained in neat stockpiles with well laid aisles and walkways for ease of access. There shall not be any projection in the walkways.

##### **Work areas:**

Loose materials, scrap, tools etc. shall not be allowed to be lying in the working areas especially in the vicinity of ladders, ramps, stairs, etc. This is more important at heights where the loose materials are liable to fall down. Spills of oil and grease should be removed immediately. An effective means of preventing loose pieces lying dangerously at heights is the provision of suitable containers/receptacles as designed for waste and scrap pieces.

##### **Protruding nails**

Protruding nails in wooden pieces is a chronic problem in the sites of civil work construction. It is worthwhile to have one or two helpers continuously to retrieving protruding nails.

##### **Scrap Yard**

Wooden scrap yard should be well away from any gas cutting or welding operations and “NO SMOKING” shall be strictly ensured there.

All other combustible scrap like cotton waste, wooden boxes, and empty paint tins shall be disposed-off safely then and there.

##### **Lighting**

Adequate lighting should be provided in and around all work areas, passage way, stairs, ladders & other areas used by personnel.

##### **Opening in floors**

All opening in floors where our workmen are liable to work or even pass through shall be either closed or barricaded. If they are closed, a visible warning sign shall be kept to indicate the opening below the cover.

## **Approach road**

The approach road from the end to the work site shall never be blocked by parking vehicles or stacking materials etc. thus blocking the movement in case of emergencies.

## **54 ERECTION & RIGGING**

### **54.1 ERECTION:**

- i. Load should be properly ascertained to identify Centre of gravity and load transfer at slinging point, before handling any equipment
- ii. A visual check must be done regarding fitness of all lifting and haulage tackles, ropes, slings, etc before every use.
- iii. The common tendency of checking gear meshing lubrication, coupling matching, hole matching etc. by feeling with a finger must be strictly curbed.
- iv. Selection of tommy bars, rollers, skids etc. should be made depending on the type of equipment to be handled.
- v. Eye bolt provided at correct slinging point for heavy machinery parts such as motors, generators, turbine, etc. should be utilized for handling.
- vi. No sling should be overloaded.
- vii. Proper quality of pulley block should be used. In no case pulley block suitable for fiber rope should be used for steel wire rope, while being used as diversion pulleys.
- viii. No person shall walk, stand or work beneath suspended load.

### **54.2 STRUCTURAL ERECTION:**

- i. The structural member should be kept in orderly manner on the ground so that they do not roll down or slide while being handled.
- ii. The structural member should be able to be taken out as per sequence of erection without disturbing the stack. At the same time, light structures should not be stacked below heavy structural members where they are likely to be damaged.
- iii. Clear passage should be left for easy handling and transportation of structures.
- iv. All person shall stand clear when a crane is sorting or shifting steel girders or other structural materials.

- v. While using spanners, riveting hammers etc. at heights, they should be tied with a rope fixed to nearby structures, so that it will not drop on the ground in case of any slip.
- vi. Only those people who are skilled in working at height should be engaged for job to be done at height. Person suffering from diseases e.g. epilepsy, blood pressure, etc. or addicted to drug/alcohol etc. should not be allowed to work at height.
- vii. Crane should be taken while lifting. Proper tag line must be used for guiding while lifting loads.
- viii. While positioning a beam or fabricated structure etc. it shall be so held that the employees hand does not get jammed against other object.
- ix. Loose bolt, nuts and tools must be kept in boxes and not on structures. Boxes must have proper anchorage.
- x. Crane should be taken to fasten the erected members properly and to secure
- xi. by guys etc. whenever necessary.
- xii. Ropes and slings should be protected by providing padding over sharp edges.
- xiii. Slings should be carefully done so as to prevent the load from slipping.
- xiv. Proper sequence of erection should be followed.
- xv. All electrically operated equipment like grinding machine, drilling machine, welding machine, etc. must have proper earthing.
- xvi. All Safety appliances like safety helmet, gloves, full body harness, must be used in erection site. Full body harness equipped with suitable life line must be worn by all persons working at height and standing on structural members. Life line must be tied to any independent strong members.
- xvii. In the process of ascending or descending a column and while placing a truss in position, it may not be possible to use body harness or provide platform; in such cases riggers with expertise in such job should be engaged. Use of nets is recommended while job is done in elevated places, where suitable platform cannot be provided. If semi-permanent cat-ladder cannot be provided, rope ladder must be used. Rope ladder should be placed in position and its top should be tied with individual strong members.
- xviii. When a column is erected, it should be kept in vertical position using a minimum of 4 guy ropes unless secured otherwise, Only after bracing system is fixed, the ropes in that axis can be removed and the other two can be removed only after roof trusses are fixed.
- xix. A lot of precautions are to be taken for erecting roof girders and roof trusses as they are usually

slender, very long and unstable by themselves. The trusses which have a bracing system should be erected first and held by separate cranes and only after bracings are fixed, the crane should be released. For all other spans, only purlins and horizontal runners need to be fixed before release of cranes. Roof truss should never be erected along with monitor roof truss. Monitor roof should be erected separately.

- xx. C.G.T. sheets should be lifted handbookly by proper system. The man on the roof should use safety belt. C.G.T sheet falling from a height can cause heavy casualty.
- xxi. C.G.T sheet should be kept tied on top. The required number of C.G.T sheet only should be lifted on top. No sheet should be left unstitched and unbolted.

## **55 PNEUMATIC COMPRESSOR**

### **55.1 Air Compression Safety Tips**

- i. Before activating any sort of pneumatic tool, it must be connected to a source of air. Whenever a part is connected weakly or fitted loosely to a corresponding piece of equipment, it can jeopardize the performance of the tool and leave you vulnerable to injury
- ii. At the inlet, the air that goes in should be clean and free of moisture, with a maximum of 90 psig pressure, unless the tool itself has a pressure rating set to a higher level. If the maximum pressure rating of a particular tool is surpassed, it could cause any given number of dangers, such as cracks, undue velocity, or faulty pressure or output torque.
- iii. In the event of anything going wrong with the air supply, make sure there is a shutoff valve within reach at all times. If something goes wrong with an air hose — for example, if it starts flapping uncontrollably — don't try to control it handbookly. Cut the air source before going near.
- iv. If a hose malfunctions or comes apart at the coupling, whipping can be prevented with two applications. One is an air fuse of proper size, which should be installed in the hose upstream. The other is a whip-inhibiting device, which should be placed along the coupling of a hose.
- v. All pneumatic tools require proper lubrication in order to function at maximum efficiency. You must apply the recommended lubricants for any given tool in question. However, it isn't wise to use a particular lubricant if you're unable to verify whether or not it's flammable.
- vi. Before you install, remove, fine-tune, or perform any kind of maintenance on your pneumatic impact tools or accessory parts, do three things: shut off the source of air, bleed the air pressure, and disengage the air hose.
- vii. Never put your hands anywhere near the end of an active pneumatic tool. For similar reasons, never allow clothing or hair to get anywhere close to the working parts of such equipment. Most of all,

never point the active end of a tool anywhere near your body or face.

- viii. Always position yourself in a firmly grounded place, and be mindful of the unpredictable nature of an active piece of machinery. Make sure you're at a safe distance from the working parts of a tool, in case abrupt changes in movement occur.
- ix. Be sure to check the air source itself on a regular basis to ensure optimal performance and efficiency.
- x. The shutoff valve should always be visible and within reach when working with compressed air.
- xi. Don't allow grease or oil to deposit or linger on an air hose; grease can cause hoses to deteriorate.
- xii. Don't allow hoses or cords to hang along floors or aisles; doing so could cause people to trip and possibly get injured and/or pull cords and cut power supplies. As an alternative, suspend hoses overhead wherever possible.
- xiii. Compressed air is not suitable for cleaning clothing or human skin. When using shop air for cleaning purposes, don't exceed 15 psi without the aid of a nozzle.
- xiv. Pneumatic tools are capable of generating static energy, and must therefore be grounded whenever activated. This is especially true when in the presence of flammable or combustible elements, such as fuel or explosives.

## **56 CONCRETE BATCHING AND MIXING PLANT**

### **56.1 Important safety tips when working with batching plants**

- i. Go through training, protocol and emergency procedures with everyone who will be operating construction equipment. If an emergency occurs and the batching plant needs to be shut off immediately, be certain that everyone knows how to turn it off.
- ii. An on-site batch plant must be located where it will not pose a hazard to the environment or affect the local community living within close proximity to the construction site. All procedures need to put in place to reduce dust emissions as much as possible such as the addition over the top of cement silos and bins containing cement and other aggregates.
- iii. Let everyone working in the control room and the job site know where the emergency shut off switch is, even people who won't be operating the batching plant. Unfortunately, accidents can happen and everyone on location needs to be prepared to shut off the equipment immediately. Or, ensure the batch plant is fitted with self-closing flow control valves or over-ride controls in case a fault occurs in controlling the flow in cement or other aggregates which go into the mixing and production of concrete.

- iv. Control rooms should be located a safe distance from where the loading and mixing of cement occur to avoid breathing in of the dust that maybe created during the weigh batching process.
- v. Make sure that everyone on site wears protective clothing, appropriate headgear and eye wear. Construction sites have strict dress codes for a reason – there are many hazardous materials and heavy-duty equipment that can be dangerous in inexperienced hands or if a fault occurs. Exposure to cement dust can irritate eyes, nose, throat and the upper respiratory system.
- vi. Don't eat or drink where cement dust is present and wash hands before you eat. To be extra cautious to avoid ingesting cement dust, protective clothing worn while operating a batch plant should be removed eating or returning home at the end of a work day.
- vii. Skip, weigh batcher & drum should be clearly visible to the operator in the cabin.
- viii. Trained persons only should operate the plant.
- ix. Weighing attachment should not be tempered with/nothing should fall on it.
- x. Mixing drum should be cleaned after completion of each and every delivery.
- xi. Workmen should be kept away from the area of operation of scrapper unit.
- xii. Plant should have proper ear thing.
- xiii. Clutch and breaks should be adjusted properly.
- xiv. Periodic inspections of wire ropeshould be done.
- xv. Overloading of the scrapper/skip unit and drum should be avoided.
- xvi. Any unwanted mechanical noise should be carefully probed into for corrective action.
- xvii. All operators and laborers for cement filling should use dust masks & helmets.

## **57 TRANSIT MIXER**

- Only trained person should be allowed to operate the equipment.
- Rear view mirrors should be provided for reversing the vehicles.
- Chutes for discharge should be fixed and angled properly.
- Nobody should create any obstruction in the way of falling concrete at the time of discharge.
- Mixing drum should be cleaned after emptying the drum on the completion of full delivery.
- Greasing of rollers should be done regularly.

- Inspection covers of the drum should be bolted properly.
- Water and air connections should be checked before operation.

## **58 MIXER**

- All gears, chain and rollers of concrete mixer should be adequately guarded to prevent damage/danger.
- Concrete mixer hopper shall be protected by side railing to prevent workers from passing under them. Operators shall make sure before lowering the skip that the operational space is absolutely clear.
- Wire rope used for hopper hoisting has to be checked thoroughly and periodically.
- Hopper hoist and anchoring brake should be checked/ adjusted for proper functioning.
- Skip hoist clutch is to be checked and adjusted if slipping occurs.
- Nothing should be kept inside the motor enclosure.
- Be sure that motor fan guard is firmly secured.
- Be sure that wiring is properly connected and insulated.
- Ensure double ear-thing to be done for electrically operated concrete mixers.
- Know how to stop the mixer instantly.
- Keep hands, clothing and tools away from moving parts and out of drum
- Disconnect electric motor before putting hands or tools in drum
- Periodical check for loose bolts and nuts and adjusted as needed.

## **59 CONCRETE PUMP**

- Only the trained person should operate the equipment.
- The pipes, bends and the snap couplings should be checked against leakage/cracks.
- O-ring with the proper size only should be used between the joints/ connections.
- Sponge balls should be used for cleaning the piping.
- The equipment should be greased periodically.

- Slurry should be passed before pumping the concrete.
- Elephant hose should be held in position with the help of rope while discharging concrete.
- Electrical connections and earthing of the equipment should be properly done.
- Proper anchoring should be done between piping and equipment.
- Counter blast should be provided with while using the equipment for high-rise buildings.

## 60 CONCRETE VIBRATOR

- Vibrating unit shall be completely enclosed and the belt transmitting power to the unit to be adequately guarded.
- Electrically operated compaction vibrators shall be totally enclosed and be protected against overloads by suitable overload relays and shall be effectively earthed.
- Be sure that the sufficient length of cable is provided to the vibrator.
- Ensure electric starters are fixed firmly on the stand.
- While needle is inserted in the vibrator, be sure that needle load is firmly locked.
- Be sure to lubricate inner core of needle.
- Before each use, check the electrical cord and plug for damage such as cuts, abrasions, and severe twisting which could cause electric shock do not use if cord is damaged or frayed.
- Always wear rubber, insulated gloves and protective boots or shoes when operating, Safety glasses should be worn at all times.
- Always carry the vibrator by grasping the motor. Never pull or drag the unit by the shaft, head or electrical cord.
- Caution should be used when handling equipment around water or when working in damp environment.
- Do not run the vibrator when not in wet concrete, the vibrator head will overheat. The vibrator should be
- kept moving in an up and down motion.
- Do not allow to children to play with a concrete vibrator.

## 61 CRANE

The capacity of the crane should be ascertained before using. Brakes should be checked while lifting critical load and adjusted, if needed.

- Crane should never be overloaded.
- Mobile cranes should be parked on hard soil or strong base. They should not be placed near the edge of the pit or excavation.
- Safe working load of any mobile crane depends on:
  - A. Operator's skills
  - B. Condition of the ground
  - C. Boom length.
  - D. Radius of rotation and inclination of boom to the vertical while lifting the load.
  - E. Out rigger blocked/free.
    - The safe working load is generally tabulated in the load chart of the crane. Sometimes crane are de-rated due to the defects in welding, bend in angle, bracing and condition of clutch brake.
    - Remember that the capacity of a crane is the total load hung from the hook including weight of hook, block, ropes, slings etc.
    - Standard signaling code properly understood by the operator and trained signal man should be used. The crane operator shall respond to signals only from the appointed signaler. But shall obey stop signal at any time no matter who gives it.
    - Tag line should be used while hoisting heavy and bulky materials.
    - The brakes, boom, hook, wire rope pulley and rope anchoring should be checked periodically by a maintenance person to ensure safe operation of a crane.
    - The load being lifted should not touch the boom.
    - The boom or any part of the crane should not come near any live electric line/ service line.
    - Swinging of load should be done smoothly.
    - Proper quality of packing should be used and the outrigger should rest tightly on the packing placed on support.

- Nobody should stand below the boom, or load.
- The operator should be positioned at high level to see the hook and load throughout the hoisting, swinging and unloading operation.
- During storm, the hook block should be anchored firmly and swing lock to be released.
- When an extended boom is used on the crane, the operator must use extreme care in lowering the load to the ground. An extended boom should never be lowered to one side of the chassis as the stability of the crane is usually reduced at that position.
- During shifting the crane has to be crawled on a heavy timber mat in case soil does not have adequate bearing capacity.
- Any make shift methods to maximize utilization of crane such as blocking with timber or adding counter weight should not be permitted.
- In idle condition the crane operator should remove load from the hook and raise the hook block to a maximum height.
- The crane operator should keep the cabin deck free from any oil, mud and grease.
- Operator should always keep the wind shield clear in order to have clear vision.
- Ensure at least two full winding of ropes always on the rope drum. After a boom extension, the hook shall be lowered to the required lowest point to ensure that at least two dead coils remain on the drum and to the highest point to check that the drum capacity will not be exceeded.

## **62 MOBILE CRANE**

Following precaution has to be taken while using tyre mounted mobile cranes in addition to those given above.

- When traveling up a gradient, the load shall be derricked out and when traveling down a gradient, the load shall be derricked into the minimum radius, and this position shall be corrected on reaching level ground. Otherwise, constant watch on the radius should be maintained while traveling on uneven surfaces.
- The mobile crane shall be fitted with suitable horn, head light, side lamps, rear and stop light and flashing direction indicator.
- A cantilever type jib of crane when traveling without load should be lowered to a horizontal position.

- The pneumatic tyres shall be maintained at the correct pressure at all times.

### **63 BENDING AND CUTTING MACHINE**

Only trained person should be allowed to operate the equipment.

- Equipment should be guarded/ earthed properly.
- Equipment should be placed on sound foundations for fixing properly.
- Bars used for cutting or bending should be of designated size as per manufacturer's catalogue of the machine.

### **64 D.G SETS**

No unauthorized person should operate.

- Make sure that only those individuals who have read the product safety instruction operate the portable generator.
- Equipment should be mounted on foundation or on levelled ground with anti-vibratory pads.
- Locking all wheels, or if no locks are available, inserting wedges under all tires to stop them from rolling.
- Avoid running generator power cords through main pathways as they are the potential tripping hazards.
- Move the generator as close to the work area as possible, and keep power cords guarded with cable covers or warning flags when possible.
- Use extreme caution if operating a generator near water. If this water is exposed to electricity, anyone nearby is at risk of potential shock.
- Do not refuel while the engine is running or hot.
- Keep fuel containers out of the way of heavily trafficked areas.
- Do not smoke or use open flames near an open generator tank or gas can.
- Keep a fire extinguisher nearby and know how to properly use it.
- When working nearby loud generators, always wear hearing protection to avoid the hearing loss.
- Equipment should be grounded/ earthed properly as required.
- Ventilation should be proper. The exhaust piping should have less bends and no restrictions.

- Safety devices should be checked/ inspected before use/ operation.
- Good foundation with tray has to be arranged to control the oil seepage in the earth.
- Remove all grease, ice, snow or materials that could create slippery conditions around the units.
- Carefully clean up any gas or oil spills before starting your generator.

## **65 USE OF COMPRESSES GAS CYLINDER**

### **65.1 UNLOADING OF CYLINDER**

- From the truck, unload directly on a raised platform by rolling over a coir mattress. If a suitable raised platform is not available, slide down each cylinder over a 15cm reinforced coir mattress, taking care that bottom end touches first.
- Lifting magnet should not be used for loading or unloading.
- Cylinder should not be loaded loosely in a vehicle falling which it will be subjected to heavy jolting and damage during the vehicle movement.

### **65.2 STORAGE**

- The cylinder store room must be well ventilated.
- Full and empty cylinder to be stored separately.
- Acetylene cylinder should be stored upright and properly secured.
- Other cylinder, if stacked horizontally, proper chocks should be used to prevent rolling
- Do not keep cylinder in battery room or oil storage room.
- Store cylinder well away from source of heat.
- Oxygen and acetylene cylinder should be stored separately

### **65.3 CARE IN USAGE OF CYLINDERS**

- Oil or grease should not come in contact with the cylinder valve assembly or the regulator fitting.
- Never allow to cylinders to come in contact with electrical apparatus or live wires.
- Do not use chain slings for lifting cylinders; only fibre sling should be used.
- Use red hose for acetylene and other fuel gases and black/green hose for oxygen. Never interchange hose.

- v. Use hose of equal length and do not coil the hoses around regulator or cylinder.
- vi. Nozzle tips shall be kept clean always; otherwise backfire may result.
- vii. Set the regulator to the recommended pressure and ensure leak-free connection.

#### **65.4 TEN COMMANDMENTS' REGARDING GAS CYLINDER**

- i. Do not issue a cylinder to site unless contents are clearly identified.
- ii. Do not use a gas cylinder unless contents are identified.
- iii. Do not handle cylinder or valve assemblies with greasy hands or oily rags.
- iv. Do not lubricate cylinder valvethreads.
- v. Do not use cylinder or rollers, work supports etc.
- vi. Do not stack cylinders near sources of heat or in direct sun.
- vii. Do not lay cylinder on direct on wet soil.
- viii. Do not place cylinders against wall or bench unsecured.
- ix. Do not keep cylinders in battery charging room or in oil room.
- x. Do not allow cylinder to come in contact with live wires.

#### **66 MONITORING AND AUDIT**

Trade Contractors adherence and compliance will be continuously monitored, both on site and through the Trade Contractors Co-ordination Meetings and Progress Review Meetings. Any non-compliance will be notified to the Trade Contractor in writing and anticipated remedial measures requested.

In addition, an Environmental Audit schedule will be compiled and implemented by the Project Director. Environmental Audits will be used to determine:

Trade Contractor compliance with Method Statements.

Trade Contractor and all other staff compliance with construction stage project-specific environmental rules. The audit schedule should: Define what frequency of auditing is required (with regard to design, pre-construction, procurement, construction and post-construction);

Obtain feedback from the design team as to how they have incorporated environmental issues in their design.

Reflect the fact that audit reports can be used to demonstrate achievements to the Client. A brief audit

report will be compiled and copies sent to:

- The Client
- The Trade Contractor
- Project Management's, Environmental Manager

Project Environmental issues will be reported as a design team meeting agenda item and should include the following where relevant:

Environmental Design Issues

Potential/actual significant environmental impacts with planned mitigation measures Any revisions/additions to the Environmental Plan

Trade Contractor compliance/non compliance Any other environmental issues.

## **67 SECURITY PLAN**

### **67.1 Security Plan to be Devised and Maintained**

Prior to commencing the Works, the Contractor shall devise a "Security Plan" for controlling the access of all persons to site. The Contractor shall submit its proposed Security Plan to the Project Manager for review, approval and revision if necessary, prior to commencing the Works.

The Security Plan shall include either a pass or token system, or other such system acceptable to the Project Manager. The names and personal particulars of every person visiting site, whether working, inspection or otherwise, shall be recorded in a log book keep by the Contractor. The system shall be so designed such that any persons removed from site by the Contractor or on the request of the Project Manager shall be easily identifiable and shall not be permitted access to the site again.

### **67.2 Construction Site Security Guard Control**

Measures to protect material and equipment and control employee and visitor access to the construction site must be defined and a system of site security procedures established.

All Contractors, their superintendents and supervisors, employees and Associated Contractors/Agencies shall comply with the requirements herein established the basic doctrine, criteria, and standards for the construction security/ guard program and.

General Contractor to establish the rules to control site access or exit of employees, visitors, material, equipment and vehicles.

CPWD does not assume any responsibility at any time for the protection of the building and premises or

for the loss of materials and/or equipment from the time that Contractor's operations commence until the final Acceptance of Contractor's Work, unless otherwise agreed in Contract documents.

### **67.3 Contracted Professional Site Security/Guard Team**

Contractor will hire professional security /guard company to provide construction site security / guard services to provide project access control and site security.

The services provided by such security guard company will include as below:

- i. Construction site access control and management, include personnel identification, visitors, asset, vehicles etc.
- ii. Security guard of IKEA site officearea
- iii. Patrol around construction site in the night shift.
- iv. Contractor shall consider their own construction materials and equipment safekeeping during construction phase.

### **67.4 Site Security Control Center (Guardhouse)**

A site security control center must be completed by GC and the Security Control Center is designated a controlled area in accordance with project contract and must contain suitable ventilation or heat and air conditioning. The room must have the following equipment:

- i. Site and surrounding area plotting wall maps
- ii. Necessary charts and checklists for normal and emergency operations
- iii. Floor plans depicting each facilities layout (A-1 drawings)
- iv. Post priority charts for normal and emergency activities with each post listed in order of importance
- v. Battery-operated 24-hour clock showing local time
- vi. Access control system console
- vii. Site monitoring system console
- viii. Emergency alarm system console
- ix. Telephones and a telephone number listing for each of the following:
  - A. ERT
  - B. Construction Site Security Office/Manager

- C. Local law enforcement agencies having jurisdiction for site
  - D. Local fire department
  - E. Nurses Office and emergency medical services
  - F. Each fixed sentry post
  - G. Contractor PM/SHE Manager
- e. 67.5 Asset Control

A property removal pass must be presented to the guard at the gate when employees of Contractors wish to remove any construction tools, equipment, or construction materials, even construction waste from site.

For all construction materials, equipment, tools etc. that will be transported to construction site, Contractor shall get approval from CPWD before mobilization.

The pass must be presented to the security guard who will be responsible for ensuring the material to be removed is properly listed and the proper approvals have been obtained. Guards reserve the right to deny entry/exit to the job site to any person refusing to comply with requests in accordance with this procedure.

If the property is being transported from the site via truck or automobile the vehicle description and license plate should also be listed on the form.

Any employee, vendor, visitor, etc., bringing their own (non-project owned) personal equipment into the job site shall register it with the security guard at the gate.

### **67.6 Vehicle Control**

- i. All vehicles, trucks working on project for long term, Contractor must provide related licenses and pass inspection, Vehicle Pass will be produced by GC and used on project.
- ii. The Guard shall check every vehicle that enters the Site for an appropriate ACCESS BADGE that is to be displayed in the windshield. Vehicles without an Access Badge shall be treated as a Visitor and not permitted on site unless they have received authorization from the person they are visiting or the direct supervisor should the vehicle belong to a jobsite employee. The Visitor must then sign in and be issued a VISITOR'S ACCESS BADGE to be displayed on the rear view mirror. Upon departure the Visitor must return the Visitor's Access Badge.
- iii. Vehicles are not permitted onto the Project unless they have Project business to conduct. Before entering a project location, Contractor will designate a person to site gate as director to ensure that

the vehicle/driver adheres to all rules and regulations and is accompanied at all times while on the project.

- iv. Speed Limited requirement: 5Km/hr. Driver license should be available

### **67.7 Personnel Identification and Control**

Site personnel shall keep their work passes or tokens on them at all times, and shall not come to site or work without their pass or token. Any person found on site without a valid pass or token shall be immediately removed from site.

### **67.8 Limit of Entry to Site**

The Contractor shall not allow entry to site of:

- i. Persons below 18 years of age & physically challenged (shall not be employed on site);
- ii. Persons under the influence of alcohol or drugs and
- iii. Person without Photo Identity.

### **67.9 Force and bonded labour**

- i. There is no forced, prison, bonded or involuntary labour.

### **67.10 Workers**

- i. have the legal right to perform work at the Supplier premises
- ii. have the freedom to terminate employment at any time according to the agreed notice period, without penalty or salary deductions.
- iii. have the freedom to leave the premises when their work shifts end.
- iv. Personal documents or other belongings are not withheld.
- v. Have not been charged, directly or indirectly, any fees or commission related to the recruitment and/or employment process. If the recruitment agent has requested any such fee, the Worker has been reimbursed by the Contractor
- vi. have not been requested to provide deposits and have not payments delayed, been offered wage advances or loans with the consequence of indebting the Worker and binding him or her to employment.
- vii. Persons found consuming alcohol or drugs on site shall be immediately removed from site and shall not be permitted re-entry.

The Project Manager may object to and direct the Contractor to remove or have removed from the site or from any activity connected with the Work under the Contract within such time as directed, any person employed by the Contractor or by any Associated Contractors/Agencies who, in the opinion of the Project Manager, misconducts themselves or is incompetent or negligent in the performance of their duties, or tends to create any danger to themselves, others or to the Works. The Contractor shall comply with such direction and any such person shall not be employed on the site or on activities connected with the Work under the Contract without the prior approval of the Project Manager.

The CPWD Project Manager may direct the Contractor to exclude from Site:

viii. Any person whose admission may, in the opinion of the Project Manager, be undesirable or pose a threat to the safety of the Department's property or to any person for whom the Department is responsible; and

ix. Any motor vehicle or item of plant or machinery that, in the opinion of the Project Manager, may pose a threat to the safety of the Contractor's or the Department's property, or to personnel on site, or for any person for whom the Department is responsible.

The decision of the Project Manager on any matter arising under this clause shall be final and conclusive.

### **67.11 Vehicle Searches**

All vehicles wishing to enter the site are to be thoroughly checked for explosive ordinance or other items that represent a threat to the security of the Project, before being allowed access to the site.

### **67.12 Bag and Clothing Searches**

All bags being brought on to site by personnel are to be thoroughly checked for explosive ordinance or other items that represent a threat to the security of the Project, before being allowed access to the site.

All bags being carried off site by personnel are to be thoroughly searched for stolen materials or equipment.

Site Security will be given the right to conduct clothing inspections (i.e. pockets, fleecing, magnetic sweeps etc) if they have reasonable grounds for suspicion of individual personnel.

### **67.13 Items not to be Removed from Site without Project Manager Approval**

No material or equipment shall be removed from site without the Project Manager's approval and signature on the Contractor's gate pass.

**68 CHILD LABOR (BELOW 18 YEARS OF AGE AND PHYSICALLY CHALLENGED)** Following the Child Labor (Prohibitions & Regulations) Act, 1986 and Rules 1950, Person below 18 will be

strictly prohibited.

Child labour will be defined as work performed by children who has not completed their 18 years of age as per ID issued by government (i.e Pan Card, ADHAR card, Passport, Driving License, Voter ID, Birth Certificate, School leaving certificate)

A poster (Child Labour/ Below 18 years) in English and local language must be fixed at each visible location (especially at entry gate).

Suspected workers shall be sent for check by a registered MBBS Doctor (Government doctors not any MBBS). Incurred cost shall be bear by Contractor only.

The Contractor has a documented policy in place to ensure that no Child labour is employed as defined in this section. In case child labour is identified at a Supplier/Contractor then IKEA's "Procedure for handling and follow up of Child Labour Violations" (Appendix-2) shall be followed.

## **69 PERSONS UNDER THE INFLUENCE OF ALCOHOL OR DRUGS**

Persons found consuming alcohol or drugs on site shall be immediately removed from site and shall not be permitted re-entry.

The Project Manager may object to and direct the Contractor to remove or have removed from the site or from any activity connected with the Work under the Contract within such time as directed, any person employed by the Contractor or by any Associated Contractors/Agencies who, in the opinion of the Project Manager, misconducts themselves or is incompetent or negligent in the performance of their duties, or tends to create any danger to themselves, others or to the Works. The Contractor shall comply with such direction and any such person shall not be employed on the site or on activities connected with the Work under the Contract without the prior approval of the Project Manager.

## **70 PERSON WITHOUT PHOTO IDENTITY**

Site personnel shall keep their work passes or tokens on them at all times, and shall not come to site or work without their pass or token. Any person found on site without a valid pass or token shall be immediately removed from site

## **71 ENVIRONMENT MANAGEMENT PLAN**

### **71.1 The Project Environmental Management Plan**

The Environmental Management Plan (EMP) will set out the framework for monitoring auditing and controlling the potential environmental effects of projects in order to insure compliance with the relevant environmental legislation. The plan will identify how sustainability issues are being applied to the project.

This will produce an environmental management system specific to the project, which will follow the general principles of the British Standard of Environmental Management Systems (ISO 14001). It is important to note that the EMP should be completed prior to the commencement of any construction projects.

An Environmental Assessment will be undertaken during the early stages following appointment, in order to identify areas of potential concern and allow the design of mitigation measures for eliminating or minimising those impacts.

### **71.2 Parties to the Environmental Management Plan**

Environmental Management Plan has been prepared in conjunction with the following parties:

CPWD

Designers

Other Project Team Members

Local Author

Other statutory authorities

Environment Agency

Other Interested Parties (specify)

### **71.3 Key Elements of Environmental Management Plan**

#### **71.3.1 Identification of Project Environmental Issues**

- **Project Description**

CPWD project

- **Key Environmental Issues**

Key environmental issues specific to the project should be identified during impact/aspect assessment utilising the following sources of information, plus any other relevant sources that may become apparent:

- The Client Brief
- Pre-Construction Health & Safety Plan
- The Client policy and any supporting environmental targets

- The Environmental Statement (ES) prepared for the project (if appropriate)
- Planning / Planning Restrictions
- Environmental Legislation
- Scope of site investigations
- Planning stage ecological survey
- Any previous works contracts relevant to the site that may be available.

The requirements of relevant environmental legislation must be identified and assessed. The following includes issues and regulations that require consideration:

Environment Protection	1.EnvironmentProtectionAct,1986 2.The Water(Prevention and Control of Pollution)Act,1974 3.Air(Prevention and Control of Pollution)Act1981
Forests	1.TheIndianForestAct,1927 2.Forest(Conservation)Act,1980
Waste Management	Hazardous Waste (Management, Handling and TransboundaryMovement)Rules,2008 Bio_Medical Waste (Management &Handling)Rules, 1998 Municipal Solid Wastes (Management &Handling Rules)
Environment impact assessment("EIA")	EnvironmentImpactAssessmentNotification,2006
Management of Chemicals	Manufacture, Storage ,and Import of Hazardous Chemical Rules,1989 Ozone Depleting Substances(Regulation and Control)Rules, 2000 The Chemical Accidents (Emergency Planning, Preparedness And Response)Rules,1996 Rules for the Manufacture, Use, Import, Export and Storage of Hazardous micro-organisms Genetically engineered organisms orcells,1989
Noise Pollution	Noise Pollution (Regulation &Control)Rules,2000

- **The Water (Prevention and Control of Pollution) Act, 1974**

- Provide information to the SPCB (State pollution control board)
- Provide access to the SPCB for taking samples
- Allow entry to the SPCB to ascertain that the provisions of the Act are being complied with.

**Responsibilities:**

- Obtain “Consent to Establish”
  - Obtain “Consent to Operate”
  - Apply for renewal of the “Consent to Operate” before the expiry of validity period
  - Consent to be deemed as granted automatically and unconditionally after four months from the date of application already given or refused before this period
  - Refusal of “Consent” to be recorded in writing
  - Pay Water Cess as indicated in the assessment order
  - Affix water meters of the prescribed standards
  - Provide access to SPCB
  - Pay interest in case of delay in paying the Water Cess
  - Pay penalty for non-payment of Cess
- **The Air (Prevention & Control of Pollution) Act, 1981**
    - Comply with the conditions in the “Consent to Establish” or “Consent to Operate”
    - Not to discharge air pollutant(s) in excess of the prescribed standards
    - Furnish information to the SPCB of any accident or unforeseen act or event
    - Allow entry to the SPCB to ascertain that provisions of the Act are being complied with
    - Provide information to enable SPCB to implement the Act
    - Provide access to the SPCB for taking samples
    - Comply with the directions issued in writing by the SPCB
    - Obtain “Consent to Establish”

- Obtain “Consent to Operate”
- Apply for the renewal of “Consent to Operate” before expiry of the validity period
- Consent to be deemed as granted after four months from the date of receipt of application if no communication from the SPCB is received
- A prior “Notice of Inspection” to be served by the SPCB
- Industry to ensure that specified emission sampling procedure is being followed by the SPCB
- Opportunity to file objections with the SPCB within 15 days from the date of service of notice
- PCB to record reasons in writing in case it does not provide an opportunity to the industry to file objections.
- **Environment (Protection) Act, 1986**

Comply with the directions issued by the Central Government. The direction may include:

- closure, prohibition or regulation of any industry, or
- stoppage or regulation of the supply of electricity, water or any other service
- Prevent discharges or emissions excess of the prescribed standards
- Furnish information of any accidental or unforeseen event
- Allow entry and inspection to ascertain compliance
- Allow samples to be taken
- Submit an “Environmental Statement” every year before 30th September to the SPCB
- Obtain prior “Environmental Clearances” from MoEF, (Ministry of Environment and forest) in case of a new project or for modernization/expansion of the existing project.
- The Hazardous Waste (Management and Handling) Rules, 1989, Amendments 2000
- Check whether the waste(s) generated covered in Schedule 1 and 2 of the amendment rules, 2000
- If covered, apply in the Prescribed Format to obtain an “Authorization” for proper treatment and disposal of hazardous waste(s) and comply with the conditions specified in the authorization
- Take steps, wherever feasible for reduction, recovery and recycling of wastes

- Ensure proper collection, reception, treatment, storage and disposal of hazardous wastes
- Apply for renewal of authorization before expiry of the validity period
- Maintain records of hazardous wastes handling
- Submit “Annual Returns” to the SPCB
- Report to the SPCB any accident
- Labelling, Packaging, Transportation of HW (Hazardous Waste) as per Motor Vehicle Act, 1988 and Rules 1989
- Identify whether the chemicals handled, used and stored or imported are covered in the Schedule 1 and/or 3 of the Rules, Schedule 2 for isolated storages.

**If covered in schedule 1:**

- Occupier to identify hazards associated with industrial activity and take adequate steps for prevention and control
- Occupier to provide relevant information to persons liable to be affected by a major accident
- Occupier to develop information in the form of a safety data sheet
- Occupier to notify the concerned authorities within 48 hours of the occurrence of a major accident
- Occupier to label the specified information on every container of hazardous chemicals.
- Occupier to submit an up-to-date safety report at least ninety days before making any modification.
- Occupiers of new and existing industrial activities to carry out safety audit and submit report within 30 days.
- Occupier to submit a safety audit update report once a year and forwarding a copy within 30 days.
- Occupier to prepare up-to-date on-site emergency plan before commencing a new industrial activity involving specified chemicals.
- Occupier shall conduct a mock drill of emergency plan every six months and submit a report.
- Occupier to maintain records of imports of hazardous chemicals and to provide information to the concerned Authority.

- Occupier to ensure the transportation of hazardous chemicals as per the provisions of the Motor Vehicles Act, 1988.
- Regulation on Recycling of Waste Materials, 1999, 2000

The waste materials targeted: waste oils, lead – acid batteries, non-ferrous wastes  
The auction / sale of these materials to only authorised recyclers who are registered with the Ministry of Environment & Forests, Govt of India

No trader can take such type of waste

- Noise Pollution (Regulation & Control) Rules, 2000

Aiming to regulate and control noise from sources like, industrial activity, construction activity, generator sets, loud speakers, public address systems, music systems, vehicular horns and other mechanical devices.

The prescribed Ambient Noise Levels are to be complied with

A loud speaker should not be used except after obtaining written permission from the authority

If the noise level exceeds the ambient standards by 10d (B) A, complaint can be lodged to the authority.

### **71.3.3 Environmental Management Structure**

The Management for the environmental aspects of the project, procedures and control shall be in accordance of prevailing law.

### **71.3.4 Consents, Licences and Authorisations**

Il relevant consents, licenses and Authorisations includes Environmental Planning Conditions, any consent under control of Pollution Act 1986 in respect of noise and vibration, any waste water discharge consent, copies of waste carrier licences, tip site licenses etc.

### **71.3.5 Environmental Emergency Plan**

The emergency measures for implementation in the event of an environmental incident on site should be read in conjunction with the Emergency Plan.

The Emergency Procedure Plan sets out the routine to be followed and contact members of project staff and emergency services. The environmental emergency plan is complimentary to this action and is for incidents, which are likely to impact on the significant environmental issues.

It should be noted that the response to an emergency incident can itself be the cause of environmental pollution, for example copious quantities of water from fire, ruptured storage tanks as a result of fire, etc.

If additional guidance is required in drawing up the environmental emergency plan, then relevant environmental enforcement authorities should be approached.

In the event that an Environmental emergency take place the following actions should be taken.

- The appropriate emergency services must be called using the usual 100 telephone number, only if necessary.
  - At least one member of CPWD staff must be contacted using their business or home telephone number where necessary, as follows:-
  - In the event that there are any safety implications.
- Ø Contactor Environmental Manager who will in turn contact External Environmental Consultant (should advice be warranted)
- Ø The following are a list of contact numbers for other agencies, which may need to be contacted in an emergency.

- SHE +91,
- Environment Agency +91,
- Local Authority (Environmental Health) +91,
- Local Water Company +91,
- Chemical spill cleanup services +91,
- Fire Brigade 101

#### **71.4 Project Specific Environmental Rules for Construction Stage**

A set of environmental rules that are appropriate, manageable and suitable to the project, the client brief and the assessment of significant environment impacts of this Plan will be established. These will however require review with the Project Team prior to the full issue of this document.

A set of proposed rules are listed below that can form the base line for the development of project specific environmental rules.

#### **71.5 Approach**

Air, Water and Land Pollution, contamination and environmental damage is a major focus area and techno-commercial efforts should be made by all Contactors, Associated Contractors/Agencies s and other representatives, to have effective control measures in place and to avoid it.

- Air Quality

Construction activities will be undertaken after installing adequate wind screens to minimize fugitive dust emission. Regular water spraying shall be undertaken to control dust during handling of cement/concrete, as well as on the haul roads. Other appropriate precautions shall be taken to minimize dust by engineering control, as and when felt necessary. Overall particulate levels in the ambient air shall not exceed the National Ambient Air Quality levels.

- Water Quality

Being a construction site the freshwater requirements would be mainly for construction purpose as well for domestic sanitation needs of the workers. Onsite construction water requirement would be minimized by increasingly using ready-mix concrete. The typical wastewater anticipated on site would be of sanitary nature. Mobile toilet facilities shall be provided on site for worker's sanitation needs and therefore no sanitary wastewater would require on site disposal. Hazardous substances will be stored under rain protective sheds to avoid any localized spills or stains to be washed away by storm water. However, the storm water of the site would be channelized through a channel of drains fitted with an oil separator before the final exit point of the storm water drain. The storm water discharge would be monitored to ensure the oil and grease quantity in the discharge remains below 10 mg/l or as per any standards specified by the regulatory agencies.

Waste water is properly treated on site and by the contractor or discharged to an authorized external waste water treatment facility and Effluent treatment plants ETP's are properly operated and maintained and are appropriate for the type and volume of effluents generated from the operations. The staff operating ETP has the appropriate competence.

- Ground Contamination

Ground contamination is immediately acted upon. Possible risks of ground contamination due to current and previous activities on site are investigated and assessed.

Any contamination identified is reported to the relevant authority and dealt with according to directives from the authority. The contractor keeps CPWD informed about the progress and outcome of the issue.

- Waste Management

For reducing waste foot print, a proper 'waste management plan' should be developed and followed by the Contractor, wherein the waste generation and segregation should be controlled at source. However, inevitable waste should be kept in segregated bins/chambers and efforts should be made towards its Reduce, Reuse and Recycle. The disposal should be done in the in line with applicable regulations and waste accounting should be ensured from generation till compliant disposal.

- Storage and Handling of Hazardous Substances

Proper storage (with secondary containments) and utilization methodology of materials that are detrimental to the environment should be ensured. Where required, only bio degradable and environment friendly materials should be selected and emphasis should be given on recycling of waste materials such as metals, plastics, glass, paper, oil & solvents. In no way, toxic spills should be allowed to percolate into the ground. Any chemical including solvents and paints, required for project should be stored either be stored in designated areas with protective bonding/kerbing or with adequate secondary containment provisions.

- Housekeeping, Landscaping and Aesthetics

Sound housekeeping shall be ensured at the site. The Contractor shall keep the Work Under the Contract clean and tidy as it proceeds and regularly remove from site all accumulated, discarded and surplus building materials and debris arising from the execution of the work including any work performed during the Defects Liability Period. The Contractor will provide full-time, dedicated clean up personnel and equipment that will constantly clean the areas affected by the works, and will remove and deposit all rubbish into bins provided for that purpose.

Landscaping and greens management at the site will be done as per requirements to be laid down by the regulatory agencies like MOEF, SPCB or urban local bodies.

- Special Substances

Paints containing lead and high VOC as well as asbestos in any form shall not be used. Similarly it shall be ensured that any Transformer or lifting equipment to be set up at the site will be filled

with only PCB (Poly-Chlorinated Biphenyl) free oil. Lead-Acid batteries if used during the construction period shall be of dry type and to be disposed through the supplier/vendor only.

- Contingency Plan

If any environmental exceedance from the thresholds laid down in the permit and standards happens (either accidental or through inadequate implementation of mitigation measures), the cause will be quickly identified and remedial action shall be taken immediately. A 'Root Cause Analysis Report' along with the 'Closure Report' will be submitted to the Project In charge of CPWD for review and record keeping. Regulatory authorities shall be informed if only required under the statutory permits and licenses or regulatory provisions.

- Continuous improvements.

Current environmental impacts from production and operations are evaluated by the contractor.

Practical plans to reduce environmental impact are documented and reviewed periodically. The plans include measurable goals, responsibilities, concrete actions and timeframes. Corresponding results from the planned actions are documented.

#### **f. 71.6 Monitoring, Reporting and Audit**

Trade Contractors adherence and compliance will be continuously monitored, both on site and through the Trade Contractors Co-ordination Meetings, Audit and Progress Review Meetings. Any non-compliance will be notified to the Trade Contractor in writing and anticipated remedial measures requested.

In addition, an Environmental Audit schedule will be compiled and implemented by the Project Director .Environmental Audits will be used to determine:

- Ø Trade Contractor compliance with Method Statements
- Ø Trade Contractor staff compliance with construction stage project-specific environmental rules The audit schedule should:
  - i. define what frequency of auditing is required (with regard to design, pre-construction, procurement, construction and post-construction);
  - ii. Obtain feedback from the design team as to how they have incorporated environmental issues in their design.
  - iii. Reflect the fact that audit reports can be used to demonstrate achievements to the Client.

A brief audit report will be compiled and copies sent to:

#### **1. The Client**

Project Environmental issues will be reported as a design team meeting agenda item and should include the following where relevant:

- iv. Environmental Design Issues
- v. Potential/actual significant environmental impacts with planned mitigation measures
- vi. Any revisions/additions to the Environmental Plan
- vii. Trade Contractor compliance/non compliance
- viii. Any other environmental issues.

## **g. 71.7 Training**

All employees should be subject to relevant environmental awareness training. This takes the shape of seminars and briefings to update current knowledge and procedures. All staff involved in activities which could influence potentially significant environmental impacts must receive job specific environmental training to ensure that the potential for adverse impacts is minimised.

All members of the Project Team, including Trade Contractors and suppliers, will need to understand the environmental objectives of the project and will need to understand, not only the environmental aspects of their activities, but also the implications for other project activities. The implementation of a programme of Environmental Awareness Training and Induction, via site inductions and workshops, will provide staff involved with the project, at all levels, a general understanding of sustainable development and the general global and local environmental issues. The areas to be covered by the Environmental Awareness Training will include all aspects of the EMP as detailed above.

Trade Contractors are encouraged to undertake in house awareness training and to include an environmental brief within their safety toolbox talks, on site.





सत्यमेव जयते

Government of India  
Ministry of Housing and Urban Affairs  
**CENTRAL PUBLIC WORKS DEPARTMENT**

