

भारत सरकार
Government of India

केन्द्रीय लोक निर्माण विभाग
C P W D

तापन, संवात और वातानुकूलन
(एच वी ए सी) कार्यों के लिए
सामान्य विनिर्देश (2017)

**GENERAL SPECIFICATIONS for
HEATING, VENTILATION &
AIR-CONDITIONING (HVAC)
WORKS (2017)**



महानिदेशालय, के.लो.नि.वि., निर्माण भवन, नई दिल्ली 110011
DIRECTORATE GENERAL, CPWD, NIRMAN BHAWAN, NEW DELHI 110011



सत्यमेव जयते

भारत सरकार

Government of India

केन्द्रीय लोक निर्माण विभाग

C P W D

तापन, संवात और वातानुकूलन
(एच वी ए सी) कार्यों के लिए
सामान्य विनिर्देश (2017)

**GENERAL SPECIFICATIONS for
HEATING, VENTILATION &
AIR-CONDITIONING (HVAC)
WORKS (2017)**



महानिदेशालय, के.लो.नि.वि., निर्माण भवन, नई दिल्ली 110011
DIRECTORATE GENERAL, CPWD, NIRMAN BHAWAN, NEW DELHI 110011

All rights reserved. No part of this publication may be reproduced in any form or by any means, electronic or mechanical, including photocopy, recording or any information storage and retrieval system, without permission, in writing from the Director General (Works), CPWD, New Delhi

GOVERNMENT OF INDIA PUBLICATION

Published Under the Authority of
Directorate General
Central Public Works Department
Nirman Bhawan, New Delhi – 110011



ABHAI SINHA
Director General



सत्यमेव जयते

भारत सरकार
Government of India



केन्द्रीय लोक निर्माण विभाग
निर्माण भवन, नई दिल्ली - 110011
Central Public Works Department
Nirman Bhawan, New Delhi-110011
Tel : 23062556/1317, Fax : 23061884
E-mail : cpwd_dgw@nic.in

FOREWORD

CPWD has been handling all types of air conditioning, heating and ventilation works right from system design to installation, commissioning, operation & maintenance in Govt. buildings since 1947. The first air-conditioning specification "General Specifications for Air -conditioning Works" was published in 1977 and revised in 2004. Since then there have been tremendous changes in the field and air-conditioning industry has progressed rapidly. The existing specifications covered central air-conditioning system with reciprocating, centrifugal and screw type chilling units only. To incorporate the latest development & technology in the field and to include heating, ventilation & cold room system the existing specifications have been revised, which cover packaged units, central air-conditioning, central heating, ventilation including ETAC Plants and cold room works. The concept of energy saving has set in with the publication of Energy Conservation Building Code 2007 by the Ministry of Power and these have been duly included in the Specifications.

It is also put on record my sincere gratitude to Sh. Mukesh Vij, SDG(ER) and Sh. S.K. Chawla, CE, PEWZ for putting their untiring efforts in preparing the draft and revising these specifications. It is also to acknowledge the contributions of Sh. C.K. Varma, CE(E), Sh. C.S. Mittal, CE(E) and Sh. D.K. Tulani, SE(E) along with the members of Specifications Committee for giving their inputs to revise these specifications. The overall guidance in general provided by Sh. Balraj Chadha, ADG(TD) is also appreciable .

Errors, omissions, suggestions for modification in this specification may be made to SE(E) TAS in the office of Chief Engineer, CSQ(E), CPWD, Nirman Bhawan, New Delhi-110011.

New Delhi
March '2017

31/03/2017

(ABHAI SINHA)
DIRECTOR GENERAL, CPWD



MUKESH VIJ
Chairman
(Spec. Committee)



सत्यमेव जयते

भारत सरकार

Government of India



CPWD

केन्द्रीय लोक निर्माण विभाग

निज़ाम पैलेस, कोलकाता-700020

Central Public Works Department

Nizam Palace, Kolkata-700020

PREFACE

CPWD General Specifications for HVAC works 2017 is the revised version of the earlier specifications released in 2004. There was a growing need to revise these specifications due to major technological changes over a period of more than a decade as well as concept of energy efficiency gaining momentum after introduction of ECBC 2007. Accordingly changes have been effected in this revision.

Almost all the chapters have been modified to align them with the tried and trusted changes that have taken place in the field of air conditioning. VRV/VRF System along with window type and split type AC have been included in this edition. Magnetic Bearing Variable Speed Centrifugal Water Chillers, chilled beams, radiant cooling system Geo thermal based air cooling system, variable flow hydronic system and variable air volume boxes are some of the new technological additions which have found place in this edition. Similarly, inclusion of List of CFC and HCFC free Refrigerant along with their ODP, GWP and application at Annexure N as well as list of cooling demand densities in chapter 2 are some of the few useful tabular additions for all practicing HVAC engineers including designers of HVAC systems.

I am indeed grateful to Shri Abhai Sinha , Director General CPWD for reposing trust in me to undertake this arduous task in a shortest period of three months. My acknowledgements are also due to Shri. Balraj Chadha ADG (TD) who has facilitated in this task amply. Further, I express my deep appreciation to Shri. S.K.Chawla, CE (E) and Shri C.S.Mittal CE (E) in drafting this revision. I also appreciate the efforts of Shri C.K.Varma, Chief Engineer CSQ (E) who has not only contributed in the form of providing useful technical contributions but also provided the requisite administrative support to make the entire exercise of the revision possible within the given time frame.

Further, I acknowledge the efforts put in by the members of the specification committee for the thorough discussion and making useful amends wherever due to make this revision a useful exercise. My special thanks to Shri. D.K.Tulani SE TAS (E) for his valuable inputs and useful contributions in making this task simple.

Errors or Omissions and suggestions for improvements if any may be brought to the notice of SE TAS (E), Office of CE CSQ (E), CPWD, Nirman Bhavan New Delhi.

Place: Kolkata
Date: March 2017

(Mukesh Vij) 31.3.2017

Spl. Director General (ER), CPWD
Chairman Specifications Committee

MEMBERS OF SPECIFICATION COMMITTEE FOR E&M WORKS

1.	Sh. Mukesh Vij, SDG(ER), CPWD	Chairman
2.	Sh. Prabhakar Singh, ADG(NDR), CPWD	Member
3.	JS&CVO or his representative	Member
4.	Sh. S.K. Chawla, CE(E)PEWZ, CPWD	Member
5.	Sh. M.K. Sharma, CE CSQ (C), CPWD	Member
6.	Sh. Gurvinder Singh, DDG(W), CPWD	Member
7.	Sh. C.K.Varma,CE(E) CSQ, CPWD,	Member
8.	Sh. Surendar Singh, CE (E), PWD	Member
9.	Sh. Sandeep Mehta, CE(E) DDA,	Spl. Invitee
10.	Chief Technical Examiner or his representative	Member
11.	CA(NDR),CPWD	Member
12.	Sh. C.S.Mittal, CPM (PNB PZ)	Member
13.	Sh. Shahbuddin Ahmed, CE(E),BFLZ	Member
14.	Sh. Ujjwal Mitra, CE(NDZ)-III	Member
15.	Sh. Bijendra Kumar, CE(NDZ)-VII	Member
16.	Sh. Ashish Singh, Director Finance.	Member
17.	Sh. Rajeev Sharma, SE (E) DCEC-VII, CPWD	Spl. Invitee
18.	Sh. S.S. Garg, S E (E) TLQA, CPWD,	Spl. Invitee
19.	Sh. D.K. Tulani, SE (E) TAS, CPWD	Member Secretary

REFERENCES OF AMENDMENTS

S. No.	Reference under which issued	Chapter No.	Item No.	Page No.	Remarks

CONTENTS

Chapter-1	GENERAL	Page
1.1	Introduction	01
1.2	Conformity with statutory acts, rules, standards and codes	02
1.3	Safety codes and labour regulations	02
1.4	Works to be arranged by the department	03
1.5	Works to be done by the contractor	03
1.6	Power supply, water supply and drainage	04
1.7	Machinery for erection	06
1.8	Completeness of the tender, Submission of programme, approval of drawings and commencement of work	06
1.9	Dispatch of material to site and their safe custody	06
1.10	Co-ordination with other agencies	06
1.11	Quality of materials and works man ship	07
1.12	Care of the building	07
1.13	Colour scheme for the equipment & components	07
1.14	Inspection and testing	08
1.15	Running in period and date of acceptance	09
1.16	Guarantee	09
1.17	Payment Terms	10
1.18	Tender drawings, Drawings for approval and Completion Drawings	10
1.19	After Sales Service	12
1.20	Documents to be furnished on completion of Installation	12

Chapter-2 SYSTEMS AND SYSTEM REQUIREMENTS

2.1	Air Conditioning System	13
2.2	Recommended Cooling Demand Densities	15
2.3	Window type A.C.	16
2.4	Split type A.C.	17
2.5	VRV/VRF System	18
2.6	Packaged Type Units	21
2.7	Central Plant	21
2.8	Central Heating System	25
2.9	Mechanical Ventilation (For Non Air Conditioned Areas)	27
2.10	ETAC Plants	31
2.11	Cold Rooms	35

Chapter-3 ARCHITECTURAL AND STRUCTURAL REQUIREMENTS

3.1	Scope	37
3.2	Packaged Type Plants	37
3.3	Central Air Conditioning Plant Room	37
3.4	Weather Maker/ AHU rooms	38
3.5	Cooling Towers	39
3.6	Central Heating System	40
3.7	Mechanical Ventilation/ Evaporative Cooling System	40
3.8	Cold Rooms	41
3.9	General Structural Requirements	42
3.10	Check list for Space Provisions for Central Air Conditioning Works	44

Chapter -4 PACKAGED TYPE AIR CONDITIONING PLANTS AND VARIABLE REFRIGERANT FLOW / VOLUME SYSTEM

4.1	Water Cooled Packaged Type Plants	45
4.2	Air Cooled Packaged Type Plants	48
4.3	Variable Refrigerant Volume / Flow System	50

Chapter –5 CENTRAL AIR CONDITIONING PLANT

5.1	Scope	54
5.2	Reciprocating Compressors	54
5.3	Scroll Compressors	56
5.4	Centrifugal Compressors (Constant Speed And Variable Speed)	56
5.5	Screw Type Compressor	62
5.6	Magnetic Bearing Variable Speed Centrifugal Water Chillers	65
5.7	Condenser	72
5.8	Chiller	75
5.9	Chiller Plant Optimizer	78
5.10	Refrigerant Plumbing	78
5.11	Microprocessor Controller	81
5.12	Installation	82
5.13	Painting	82

Chapter -6 FACTORY BUILT AIR HANDLING UNIT (AHU), FAN COIL UNIT (FCU) AND OTHER AIR DISTRIBUTION SYSTEMS

6.1	Scope	83
6.2	Factory Built Air Handling Unit (AHU)	83
6.3	Fan Coil Units	88
6.4	Insulation	89

6.5	Painting	89
6.6	Chilled Beams	90
6.7	Variable Air Volume System	91
6.8	Radiant Cooling System	92
6.9	Geo Thermal Based Air Cooling System	93

Chapter -7 COOLING TOWERS

7.1	Scope	95
7.2	Type	95
7.3	Design	95
7.4	Material and Construction	96
7.5	Installation	97
7.6	Painting	97

Chapter –8 CIRCULATING WATER PUMPS

8.1	Scope	98
8.2	Type	98
8.3	Rating	98
8.4	Material and Construction	98
8.5	Accessories	99
8.6	Insulation	99
8.7	Installation	99
8.8	Painting	100
8.9	Variable Flow Hydronic Systems	100

Chapter-9 DUCTING

9.1	Scope	101
-----	-------	-----

9.2	Material	101
9.3	Construction	102
9.4	Fire Dampers	105
9.5	Variable Air Volume (VAV) Boxes	105
9.6	Acoustic Lining And Insulation	106
9.7	Flexible Ducting	106
9.8	Installation Of Metallic Duct	107
9.9	Balancing	108
9.10	Measurement	108

Chapter-10 WATER PLUMBING WORK

10.1	Scope	110
10.2	Plumbing Design	110
10.3	Pipe Materials	110
10.4	Pipe Joints	111
10.5	Pre Insulated Chilled Water Pipes	111
10.6	Valves	113
10.7	Strainers	113
10.8	Instruments	114
10.9	Expansion Tanks	115
10.10	Installation	115
10.11	Pressure Testing	117
10.12	Balancing	117
10.13	Measurement	118
10.14	Insulation	118

Chapter-11 INSULATION WORK

11.1	Scope	119
11.2	Material –Types	119
11.3	Material Specifications	120
11.4	Insulation Thickness	121
11.5	Application Of Insulation On Pipes (Including Suction Line Insulation)	121
11.6	Application Of Insulation On Pumps	122
11.7	Application Of Insulation On Expansion Tank	122
11.8	Application Of Insulation (Thermal) On Duct	122
11.9	Application Of Duct Lining (Acoustic Insulation)	123
11.10	Application Of Acoustic Lining In AHU Rooms	123
11.11	Measurement Of Insulation	123

Chapter –12 CONTROLS

12.1	Scope	125
12.2	Equipment Safety Controls	125
12.3	Refrigerant Flow Controls	126
12.4	System Controls	128
12.5	Operational Controls And Interlocks	128
12.6	Requirements Of Control Elements	129
12.7	Special Requirements For Cold Storages	131
12.8	Variable Speed Drive (VSD)	131
12.9	Economizer	134
12.10	Energy Recovery Wheel	135
12.11	Time Clock Control	138

12.12	Temperature Control	138
12.13	Demand Based Control	138

Chapter –13 ELECTRICAL WORK

13.1	Scope	140
13.2	General	140
13.3	Switch Boards	140
13.4	Power Cabling	141
13.5	Control Wiring	142
13.6	Earthing	143
13.7	Power Factor Capacitors	143
13.8	Remote Control Cum Indicating Panel	144
13.9	Motor Starter	144
13.10	Painting	145
13.11	Motor Efficiency	145

Chapter –14 CENTRAL HEATING SYSTEM

14.1	Scope	146
14.2	Electrically Operated Hot Water Generator	146
14.3	Painting	147

Chapter-15 MECHANICAL VENTILATION SYSTEM AND ETAC PLANTS

15.1	Scope	148
15.2	Centrifugal Fans	148
15.3	Axial Flow Fans	148
15.4	Propeller Fans	150
15.5	Roof Mounted Fans	150
15.6	Evaporative Type Air Cooling (ETAC)	151

15.7	Exhaust Unit	152
15.8	Two Stage Evaporative Coolers	152
15.9	Package Type Air Washers	153
15.10	Scrubber	154
15.11	Painting	156
Chapter-16 COLD ROOMS		
16.1	Scope	157
16.2	Compressor	157
16.3	Drive Arrangement	157
16.4	Motor	157
16.5	Condenser	157
16.6	Product Cooler	158
16.7	Refrigeration Piping	158
16.8	Defrosting & Reheat Arrangement	158
16.9	Painting	158
Chapter-17 INSPECTION, TESTING AND COMMISSIONING		
17.1	Scope	159
17.2	Initial Inspection At Manufacturer's Works	159
17.3	Initial Inspection At Site	161
17.4	Final Inspection	163
17.5	Testing Requirements And Procedures	163
Chapter –18 BUILDING MANAGEMENT SYSTEM		
18.1	Scope	168
18.2	System Architecture	168

18.3	Interface And Integration	169
18.4	Digital Controllers	169
18.5	Field Devices	171
18.6	BMS I-O (Input-Output) Summary	174

APPENDICES

	Page
A. Terminology	177
B. List of Relevant Indian Standards	182
C. I.S. Safety Codes	183
D. Heat Load Calculation Proforma	184
E. Heat Load Calculation Proforma For Cold Storage	185
F. Proforma for Schedule of Technical particulars	187
G. Proforma For Test Results And Notes On Test Instruments And Capacity Computations.	194
H. Maintenance	197
I. Typical A.C. Plant room Layout	203
J. Typical AHU room Layout	204
K. Typical Piping connection for AHU, Condenser/ Chiller & Pumps	205
L. Air –Side Economizer Acceptance Procedures	206
M. Values Of Performance Characteristics of Energy Efficiency Induction Motors	207
N. List of CFC and HCFC Free Refrigerants	211

CHAPTER -1

GENERAL

1.1 INTRODUCTION

1.1.1 Scope

1.1.1.1 These specifications cover the following types of air-conditioning, heating, ventilation and cold room works:

- i) Window AC , Split AC
- ii) VRV/ VRF type Air-conditioning System
- iii) Packaged type Air- conditioning plants
- iv) Central air-conditioning system
- v) Central heating system.
- vi) Mechanical ventilation system :
 - a) General Ventilation
 - b) Basement Parking & Shaft Ventilation
- vii) Evaporative type Air Cooling Plant.
- viii) Cold rooms.

1.1.1.2 Central air-conditioning system included in these specifications is by means of reciprocating / **Scroll** or centrifugal or screw type compressors. Therefore, only vapour compression type refrigeration equipments are covered herein. Absorption type refrigeration equipments are excluded from the scope of these specifications.

1.1.1.3 Water coolers / desert coolers and water softening plants for treatment of water are also excluded from the scope of these specifications.

1.1.1.4 These General Specifications cover the equipments and materials for the system, their testing and/ or inspection as may be necessary before their dispatch from their respective works, their delivery at site, all preparatory works, assembling, installation and adjustments, commissioning, final testing, putting into operation, equipment capacity computation and handing over of the complete system.

1.1.1.5 These General Specifications are subject to revision from time to time.

1.1.1.6 Each air-conditioning work has its own particular requirements. These General Specifications shall be supplemented with tender specifications as may be required for a particular work. The tender specifications, wherever they differ from these General Specifications, shall have over- riding value and shall be followed for that particular work.

1.1.2 Related Documents

These General Specifications shall be read in conjunction with the General conditions of contract. These General Specifications shall also be read in conjunction with the tender specifications, schedule of work, drawings and other documents connected with the work.

1.1.3 Terminology

The definition of terms used in these specifications shall be in accordance with IS: 3615- "Glossary of terms used in refrigeration and air-conditioning". Some of the commonly used terms are defined in Appendix 'A'.

1.1.4 Site Information

The tenderer should, in his own interest, visit the site and familiarise himself with the site conditions before tendering. For any clarification, tenderer may discuss with the Engineer-in-Charge.

1.1.5 Heat Load Calculations and Equipment Selection

- i) The successful bidder/ contractor should give detailed heat load calculations , immediately after award of work as per Appendix'D' separately for all the seasons in which, the specified conditions are to be maintained.
- ii) The successful Bidder/Contractor should also give the above heat load calculations wherever required separately for the areas served by each AHU in a central air conditioning/ heating system.
- iii) The equipment selection and duct design shall be made on the basis of the above heat load calculations wherever required.
- iv) The Contractor can refer and utilize the design done by the department/ consultants for the department, however, there shall be no commitment to provide the same to the contractor, nor the contractor shall be absolved of the responsibility of correct design and performance of the air-conditioning system provided by him.

1.2 **CONFORMITY WITH STATUTORY ACTS, RULES, STANDARDS AND CODES**

- i) All components shall conform to relevant Indian Standard Specifications, wherever existing, amended to date. A list of such standards is appended in Appendix 'B'.
- ii) **All works shall conform to National Building code as well as relevant BIS codes.**
- iii) All electrical works shall be carried out in accordance with the provisions of Indian Electricity Act, 2003 and Indian Electricity Rules, 1956 amended to date. They shall also conform to CPWD General Specifications for Electrical works, Part-I: Internal, 2013 and Part-II: External, 1994 and Part IV (Sub-station), 2013, as amended to date.
- iv) **All components shall conform to Energy Conservation Building Code 2007 of India as amended or revised up to date.**

1.3 **SAFETY CODES AND LABOUR REGULATIONS**

- i) All the safety procedures outlined in the safety codes listed in Appendix'C' shall be complied with.
- ii) In respect of all labour employed directly or indirectly on the work for the performance of the air conditioning contractor's part of work, the

contractor at his own expense, will arrange for the safety provisions as per the statutory provisions, B.I.S recommendations, factory act, workman's compensation act, CPWD code and instructions issued from time to time. Failure to provide such safety requirements would make the tenderer liable for penalty as provided in the labour laws/ GCC for each violation. In addition the Engineer-in-charge, shall be at liberty to make arrangements and provide facilities as aforesaid and recover the cost from the contractor.

- iii) The contractor shall provide necessary barriers, warning signals and other safety measures while laying pipelines, ducts cables etc. or wherever necessary so as to avoid accident. He shall also indemnify CPWD against claims for compensation arising out of negligence in this respect. Contractor shall be liable, in accordance with the Indian Law and Regulations for any accident occurring due to any cause. The department shall not be responsible for any accident occurred or damage incurred or claims arising there from during the execution of work. The contractor shall also provide all insurance including third party insurance as may be necessary to cover the risk. No extra payment would be made to the contractor due to the above provisions thereof.

1.4 WORKS TO BE ARRANGED BY THE DEPARTMENT

Unless otherwise specified in the tender documents, the following works shall be arranged by the Department:

- (i) Space for accommodating all the equipments and components involved in the work,
- (ii) False ceiling and/ or return air enclosure excluding return air duct wherever provided as required,
- (iii) Make up water tank for condenser water,
- (iv) Power supply, Water supply and Drain points as per para 1.6,
- (v) Masonry ducts/ service trench within and outside the building for carrying pipe lines and cables wherever specified.
- (vi) If top floor is air conditioned, over-deck insulation.

1.5 WORKS TO BE DONE BY THE CONTRACTOR

Unless otherwise mentioned in the tender documents, the following works shall be done by the contractor and therefore, their cost shall be deemed to be included in their tendered cost whether specifically indicated in the schedule of work or not: -

- i) Foundations for equipments including foundation bolts and vibration isolation spring/ pads,
- ii) Support columns and beams for cooling towers,
- iii) Suspenders, brackets and floor/ wall supports for suspending/ supporting ducts and pipes,
- iv) Suspenders and/ or cable trays for laying the cables,

- v) Excavation and refilling of trenches in soil wherever the pipes are to be laid directly in ground, including necessary base treatment and supports,
- vi) Sealing of all floor slab/ wall openings provided by the Department or contractor for pipes and cables, from fire safety point of view, after laying of the same,
- vii) Painting of all exposed metal surfaces of equipments and components with appropriate colour as per para 1.13.
- viii) Making openings in the walls/ floors/ slabs or modification in the existing openings wherever provided for carrying pipe line, ducts, cables etc.
- ix) Providing wooden/ metallic frames for fixing grills/ diffusers.
- x) Making good all damages caused to the structure during installation and restoring the same to their original finish.
- xi) Balancing of all HVAC systems in accordance with generally accepted engineering standards. A written balance report shall be provided (wherever asked for) to the Engineer-in-Charge or his representative for HVAC systems serving zones with a total conditioned area exceeding 500m².
- xii) A set of three copies of operations manual shall be provided to the Engineer-in-Charge or his representative containing following information at a minimum-
 - a) HVAC equipment capacity,
 - b) Equipment operation and maintenance manuals,
 - c) HVAC system control maintenance and calibration information, including wiring diagrams, schedules, and control sequence descriptions,
 - d) A complete written narrative of how each system is intended to operate.

1.6 POWER SUPPLY, WATER SUPPLY AND DRAINAGE

1.6.1 Power Supply

- i) Unless otherwise specified, 3 phase, 415 Volts, 50 Hz power supply shall be provided by the department free of charge to the contractor at one point for installation at site. Termination switchgear however, shall be provided by the contractor. Further extension if required shall be done by the contractor.
- ii) The power supply for testing and commissioning of the complete installation shall be made available by the Department free of charge to the contractor. For this purpose, the power supply shall be given at the main incomer unit of the main electrical panel (provided by the contractor) through U.G. cable, or bus-trunking arrangement. The termination of this feeder in the main incomer unit shall be the responsibility of the contractor and nothing extra shall be paid on this account.
- iii) Unless otherwise specified in the contract, further power distribution to the various equipments shall be done by the contractor.

- iv) Where the power supply has to be arranged by the Department at more than one point as per the terms of the contract, the termination of all such power feeders in the incomer of respective control panels (provided by the contractor) shall be the responsibility of the contractor.
- v) The contractor shall not use the power supply for any other purpose than that for which it is intended for. No major fabrication work shall be done at site. Power shall be used only for welding/ cutting works. The power supply shall be disconnected in case of such default and the contractor shall then have to arrange the required power supply at his cost.
- vi) Wherever there is a possibility of lower supply voltage, which does not allow motors to be operated, necessary voltage correction devices like HT voltage regulator/ ON- Load tap changer/ Servo Stabilizer etc. may be provided to ensure proper voltage.
- vii) Power supply shall also be backed by suitable standby DG set. It is necessary to provide stand by supply to fan motors of all AHUs, to ensure air circulation in air conditioning areas when the AC plant is not working due to non availability of normal electrical supply.
- viii) Additionally where the air conditioning is a functional/ critical requirement such as hospitals, computer centers, labs, or in buildings of Operational/ National importance etc., provision shall be made by the department for operation of suitable number of chilling units on standby power supply.

1.6.2 Water Supply

- i) Water supply shall be made available to the contractor by the Department free of charge at only one point for installation. Further extension if required shall be done by the contractor.
- ii) Water shall be made available by the Department free of charge in makeup water tank near the cooling tower, AC plant room, AHU room, expansion tank, hot water generator, air washer, etc. as required for testing and commissioning. Further connection from makeup water tank to cooling tower shall be carried out by the contractor and shall be separately measured & paid for as per contract.
- iii) Water analysis should be obtained of the water available at site and if required water softening plant may be provided.

1.6.3 Drainage

- i) Drain traps in A.C. plant room, AHU room, Air washer room, hot water generator and near cooling tower shall be arranged by the department.
- ii) All drainage arrangements from the drain traps in the A.C. plant room, AHU room, air washer room, hot water generator room etc. to the drain line shall be arranged by the Department as required.
- iii) Piping Connections from the equipment to the drain trap including providing valves at the drain points shall be done by the contractor. These items of work shall be separately measured and paid as per contract.

1.7 MACHINERY FOR ERECTION

All tools and tackles, heavy machinery handling equipment, etc. required for unloading/ handling of equipments and materials at site, their assembly, erection, testing and commissioning shall be the responsibility of the contractor.

1.8 COMPLETENESS OF THE TENDER, SUBMISSION OF PROGRAMME, APPROVAL OF DRAWINGS AND COMMENCEMENT OF WORK

i) Completeness of the tender

All sundry equipments, fittings, assemblies, accessories, hardware items, gaskets, masonry platforms/ foundation for Chilling Units, pumps, Cooling Towers etc., supports for pipes foundation bolts, supports, termination lugs for electrical connections, cable glands, junction boxes and all other items which are useful and necessary for proper assembly and efficient working of the various equipments and components of the work shall be deemed to have been included in the tender, irrespective of the fact whether such items are specifically mentioned in the tender or not.

ii) Submission of programme

Within fifteen days from the date of receipt of the letter of acceptance, the successful tenderer shall submit his programme for submission of drawings, supply of equipment, installation, testing, commissioning and handing over of the installation to the Engineer-in-Charge. This programme shall be framed keeping in view the milestones stipulated in the contract, building progress. Items like ducting, piping etc. that directly affect the building progress shall be given priority.

iii) Submission of Drawings

The contractor shall submit the drawings to the Engineer-in-Charge as per para 1.18.2 for approval before start of work.

iv) Commencement of Work

The contractor shall commence work as soon as the drawings submitted by him are approved.

1.9 DISPATCH OF MATERIALS TO SITE AND THEIR SAFE CUSTODY

The contractor shall dispatch materials to site in consultation with the Engineer-in-Charge. Suitable lockable storage accommodation shall be made available free of charge temporarily. Watch & ward however, shall be the responsibility of contractor. Programme of dispatch of material shall be framed keeping in view the building progress. Safe custody of all machinery and equipment supplied by the contractor shall be the responsibility of the contractor till final taking over by the department.

1.10 CO-ORDINATION WITH OTHER AGENCIES

The contractor shall co-ordinate with all other agencies involved in the work so that the work of other agencies is not hampered due to delay in his work.

Ducting, piping, cabling or any other work, which directly affect the progress of building work, shall be given priority.

1.11 QUALITY OF MATERIALS AND WORKMANSHIP

- i) The components of the installation shall be of such design so as to satisfactorily function under all conditions of operation.
- ii) The entire work of manufacture/ fabrication, assembly and installation shall conform to sound engineering practice. The entire installation shall be such as to cause minimum transmission of noise and vibration to the building structure.
- iii) All equipments and materials to be used in work shall be manufactured in factories of good repute having excellent track record of quality manufacturing, performance and proper after sales service.
- iv) None of the equipment/ machines supplied shall be more than Six months old from date of supply at site, Copy of Excise Gate Pass/ Invoice/ Shipment /Custom Clearance certificate/ details (in case of Imported equipments) shall be submitted to prove the date of manufacture & genuineness of the equipments/ machines supplied.

1.12 CARE OF THE BUILDING

Care shall be taken by the contractor during execution of the work to avoid damage to the building. He shall be responsible for repairing all such damages and restoring the same to the original finish at his cost. He shall also remove all unwanted and waste materials arising out of the installation from the site of work from time to time.

1.13 COLOUR SCHEME FOR THE EQUIPMENTS AND COMPONENTS

- i) Colour scheme for equipment like chilling unit, pumps, AHUs, cooling tower etc. shall be as per manufacturer's standard colour scheme.
- ii) The scheme of colour code painting of pipe work services for air conditioning installation shall be as per National building code and is indicated below:

Description	Ground colour	Lettering colour	First colour band
Condenser water piping	Sea Green	Black	French Blue
Chilled water piping	Sea Green	Black	Black
Central heating piping Below 60 deg C	Sea Green	Black	Canary Yellow
Central heating piping 60 deg C to 100 deg C	Sea Green	Black	Dark Violet
Drain pipe	Black	White	
Vents	White	Black	
Valves and pipe line fittings	White with black handles	Black	
Belt guard	Black & Yellow diagonal strips		
Machine Bases, Inertia Bases and Plinth	Charcoal Grey		

- iii) Colour bands shall be 150mm wide, superimposed on ground colour to distinguish type and condition of fluids. The spacing of band shall not exceed 4.0m.
- iv) In addition to the colour bands specified above all pipe work shall be legibly marked with black or white letters to indicate the type of service and the direction of flow identified as follows:-

High temperature Hot water	:	HTHW
Medium temperature Hot water	:	MTHW
Low temperature Hot water	:	LTHW
Chilled water	:	CHW
Condenser water	:	CDW
Steam	:	ST
Condensate	:	C

1.14 INSPECTION AND TESTING

1.14.1 Initial Inspection & testing

- i) Initial inspection of materials & equipments at manufacturer's as per details given in chapter 17 will be done by the engineer-in-charge or his representative. For item/ equipment requiring initial inspection at manufacturer's works, the contractor will intimate the date of testing of equipments at the manufacturer's works before dispatch. The contractor shall give sufficient advance notice regarding the dates proposed for such tests to the department's representative(s) to facilitate his presence during testing. The Engineer-in-charge at his discretion may witness such testing. Equipments will be inspected at the manufacturer/ authorised dealer's premises, before dispatch to the site by the contractor. For equipment sourced from abroad, the contractor shall include in his bid the costs of journey & stay, other costs if any, for sending his technically competent representative to witness the performance and pre-dispatch tests at the manufacturer's works. Evidence to this effect by way of travel documents etc. shall be produced before the payment against delivery is released. The Engineer-in-charge, at his discretion, may also witness such testing subject to Government Orders at that time.
- ii) The department also reserves the right to inspect the fabrication job at factory and the successful tenderer has to make arrangements for the same.
- v) The materials duly inspected by Engineer-in-Charge or his authorised representative shall be dispatched to site by the contractor.
- vi) No additional payment shall be made to the contractor for initial inspection /testing at the manufacturer's works by the representative of the Engineer-in-Charge. However, the department will bear the expenses of its representative deputed for carrying out initial inspection/testing.

1.14.2 Final Inspection & Testing

Final Inspection & testing will be done by the Engineer-in-Charge or his representative as per details indicated in Chapter 17.

1.14.3 Safety measures

All equipments shall incorporate suitable safety provisions to ensure safety of the operating personnel at all times. The initial and final inspection reports shall bring out explicitly the safety provisions incorporated in each equipment.

1.15 RUNNING IN PERIOD & DATE OF ACCEPTANCE

- i) After the installation work has been completed by the contractor, he will conduct tests and make adjustments as may be necessary to satisfy himself that the plant including low side equipments is capable of continuous running. There after he will offer to the department a running-in period of 7 days subject to a minimum aggregate of 120 hrs at his cost. The duty cycle of the plant during this running in period shall be same as that specified in the tender documents. In case of multiple compressor installations, all the compressors should be run by rotation. The plant will be operated and a log of all parameters will be maintained during this period. The contractor will be free to carry out necessary adjustments etc. during this period without stopping the plant. Record of inside conditions will be made during this period to check that the same are as per NIT requirements. The plant will be said to have successfully completed the running-in-period, if no break down or abnormal/unsatisfactory operation of any machinery occurs during this period. After this the plant will be made available for beneficial use. After the plant has operated without any major break down/ trouble and inside conditions are maintained as per NIT requirements for the above specified running in period, it shall be taken over by the department subject to guarantee clause mentioned below. This date of taking over of plant after trouble free operation during the running in period shall be the date of acceptance.
- ii) Any loss of refrigerant or oil during the running in period shall be made good by the contractor free of charge.
- iii) Capacity test of the chilling unit & other major equipments shall be carried out as and when conditions become stabilized as per details given under Appendix 'G'.
- iv) Seasonal testing may be carried out as & when outside conditions become suitable for the Major Season Test.

1.16 GUARANTEE

- i) The contractor shall guarantee the complete system to maintain the specified conditions under all conditions of ambience and internal loads subject to the condition that designed outside conditions & designed internal loads are not exceeded. Also the inlet/ outlet temperatures at the specified flow of water in the chiller unit shall be guaranteed.
- ii) All equipments shall be guaranteed for a period of 12 months from the date of acceptance and taking over of the installation by the Department against unsatisfactory performance and/or breakdown due to defective design, material, manufacture, workmanship or installation. The equipment or component or any part thereof so found defective during the guarantee period shall be repaired or replaced free of cost to

the satisfaction of the Engineer-in-Charge. In case it is felt by the department that undue delay is being caused by the contractor in doing this, the same will be got done by the department at the risk & cost of the contractor. The decision of Engineer-in-Charge in this regard shall be final.

- iii) Any leakage of refrigerant and/or oil due to defective design, manufacture, workmanship or installation during the guarantee period shall be made good by the contractor free of charge.

1.17 PAYMENT TERMS

1.17.1 The following percentage of contract rates shall be payable against the stages of work shown herein:

S.No.	Stage of work	Machinery & Equipment	All other items
I	After initial inspection (wherever specified) & delivery at site in good condition on pro-rata basis	80%	70%
II	On completion of pro-rata installation	10 %	20 %
III	On commissioning and completion of successful running in period	5 %	5 %
IV	On completion of major seasonal test	5 %	5 %

1.17.2 When the major seasonal test cannot be carried out on commissioning of the installation due to any reason not attributable to the contractor, the installation will be handed over to the Department for beneficial use after completion of successful running in test of 7 days subject to a minimum aggregate of 120 hours as per para 1.15 above. The balance payment shall be released to the contractor on his furnishing a bank guarantee in the specified format from a scheduled bank for an equivalent amount. The bank guarantee shall be valid for a period of 6 months. However it will be extended till the successful completion of the major seasonal test. This bank guarantee shall be independent of the one furnished for performance guarantee.

1.17.3 The following shall be considered major seasonal test for the purpose of the above payment terms: -

- a) Air-conditioning system : Summer or monsoon
- b) Central heating system : Winter
- c) ETAC : Summer
- d) Cold room/ Walk in cooler : Summer

1.18 TENDER DRAWINGS, DRAWINGS FOR APPROVAL & COMPLETION DRAWINGS

1.18.1 Tender Drawings

The drawings appended/ uploaded with the tender documents are intended to show the areas to be conditioned, space allotted for various equipments, tentative duct, cable and pipe routes. The equipments offered shall be suitable for installation in the spaces shown in these drawings.

1.18.2 Drawings for approval on award of the work (Not applicable in case of Window and Split AC)

The contractor shall prepare & submit three sets of hard copy & one Digital/ soft copy in AutoCAD format of following drawings and get them approved from the Engineer-in-Charge before the start of the work. The approval of drawings however does not absolve the contractor not to supply the equipments/ materials as per agreement, if there is any contradiction between the approved drawings and agreement.

- i) Lay out drawings of the equipments to be installed in various rooms such as plant room, AHU rooms, hot water generator room, cooling tower and other equipments.
- ii) Drawings including section, showing the details of erection of entire equipments including their foundations, water basin for the cooling towers / air washers, etc.
- iii) Plumbing drawings showing the layout of entire piping, dia & length of pipes, valves and isometric drawings showing connections to various equipment.
- iv) Ducting drawings showing sizes, locations of dampers, grilles & diffusers.
- v) Electrical wiring diagrams for all electrical equipments and controls including the sizes and capacities of the various cables and equipments,
- vi) Dimensioned drawings of all electrical and control panels,
- vii) Drawings showing the details of all insulations and vapour barrier works,
- viii) Drawings showing details of supports for pipes, cable trays, ducts etc.
- ix) Any other drawings relevant to the work.

The department shall, at its discretion, use the soft copy of such drawings to prepare and examine the integrated services layout, resolve conflicts, and advise the contractor to modify the execution drawings suiting & adjusting to all the services requirements. The contractor shall be bound to modify & execute accordingly.

1.18.3 Completion Drawings (Not applicable in case of Window and Split AC)

One set of Digital/ soft Copy and one set of the following laminated drawings shall be submitted by the contractor while handing over the installation to the Department. Out of this one of the sets shall be laminated on a hard base for display in the A.C. plant room. In addition one set will be given on compact disc.

- (i) Plant installation drawings giving complete details of all the equipments, including their foundations,
- (ii) AHU room installation drawings,
- (iii) Plumbing layout drawings including insulation giving sizes and lengths of all the pipes and the sizes and locations of all types of valves, and including isometric drawings for the entire piping including the pipe connections to the various equipments and insulation details wherever required,
- (iv) Duct layout drawings with their sizes and locations, and sizes and locations of all dampers, grills & diffusers,
- (v) Line diagram and layout of all electrical control panels giving switchgear ratings and their disposition, cable feeder sizes and their layout,
- (vi) Control wiring drawings with all control components and sequence of operations to explain the operation of control circuits,

(vii) BMS drawings (wherever applicable)

1.19 AFTER SALES SERVICES

The contractor shall ensure adequate and prompt after sales service in the form of maintenance, spares and personnel as and when required and shall minimise the breakdown period. In case of equipment supplied by other manufacturers the firm shall furnish a guarantee from the manufacturer for the same before the plant is taken over.

1.20 DOCUMENTS TO BE FURNISHED ON COMPLETION OF INSTALLATION

Three sets of the following documents shall be furnished to the department by the contractor on completion of work:-

- a) Completion drawings as per 1.18.3,
- b) One set in Digital form and 1 set in printed form of manufacturer's technical catalogues of all equipments and accessories,
- c) Operation and maintenance manual of all major equipments, detailing all adjustments, operation and maintenance procedure.

CHAPTER -2

SYSTEMS AND SYSTEM REQUIREMENTS

2.1 AIR-CONDITIONING SYSTEM

An air-conditioning system is a means of cooling/ heating, dehumidification/ humidification, filtration and its distribution to the various conditioned spaces , maintaining indoor air quality, energy efficiency and other resources . Various types of air-conditioning systems commonly used are:-

- a) Unit type equipments, which may be a window type room air-conditioner or a split type air-conditioner.
- b) Packaged type units, which may be fully self contained (factory assembled), or split type units.
- c) VRV/ VRF system
- d) Central plants, which are of two types :-
 - i) Central DX-Plants with AHUs etc.
 - ii) Central chilled water plants with AHUs, Fan Coil Units, Chilled Beams, Embedded chilled water pipes in slabs & walls, etc.

For each application there will specifically be only one system, which will be just right for it.

2.1.1 DRAWINGS

2.1.1.1 Following drawings shall be enclosed with tender documents :

- a) All floors HVAC layout
- b) Chilled & Condenser water SLD
- c) Electrical SLD for HVAC Panels

2.1.1.2 No other drawings shall be made available. The contractor may visit the site or discuss with Engineer-in-charge for any other site particular that he may need before submitting the tender.

2.1.1.3 Drawings have been prepared showing the areas to be Air conditioned & space allocated for the equipment. Adequacy of the plant room, AHU rooms etc for the equipment offered should be checked & confirmed by tenderer.

2.1.1.4 The above drawings represent a feasible scheme. Equipment layout, chilled water piping scheme, duct layout, sizes of grilles etc. shown in the drawings can be rearranged/ changed as per site/ Architectural requirements in consultation and with prior approval of Engineer-in-charge.

2.1.1.5 These are not working drawings. The contractor shall prepare detailed working drawings & execute the work as per working drawings approved by the Engineer-in-charge.

2.1.2 DESIGN PARAMETERS

2.1.2.1 CHILLING UNIT

- i) Centrifugal chilling unit : CFC and HCFC free refrigerant.
- ii) Suction temperature : As per manufacturer standard
- iii) Condensing temperature : design to suit duty of Water Chilling Unit

- iv) Condenser :
 - a) Water temperature IN 32.2deg C
 - b) Water temperature OUT 36.4 deg C
 - c) Temperature rise 4.2 deg C
 - d) Fouling factor 0.001(British unit)
 - e) Maximum permissible pressure drop: 10 m of water- head

- v) Chiller :
 - a) Water temperature IN 12.2 deg C
 - b) Water temperature OUT 6.67 deg C
 - c) Temperature drop 5.5 deg C
 - d) Fouling factor 0.0005 (British unit)
 - e) Maximum permissible pressure drop: 10 m of water- head

2.1.2.2 PIPING

- i) Maximum flow velocity : 2.5 m/s
- ii) Maximum friction : 5 m/100 m run

2.1.2.3 AIR HANDLING UNIT

- i) Maximum face velocity across cooling coil : 155 m/min
- ii) Maximum outlet air velocity : 610 m/min
- iii) Maximum velocity across filters :
 - a) Ordinary filters 155 m/min
 - b) Micro-vee filters 155 m/min
 - c) HEPA filters 155 m/min
- iv) Minimum spray density for humidification : 10 lpm/sq.m

2.1.2.4 DUCTING FOR AIRCONDITIONING (office Building)

- i) Maximum flow velocity :

	<u>MainDuct</u>	<u>Branch duct</u>
	400 m/min	250 m/min

- ii) Maximum velocity at supply air grilles/ diffusers : 150 m/min
- iii) Maximum friction in duct : 1cm WG/100 m run

2.1.2.5 DUCTING FOR AUDITORIUM ,CONFERENCE HALL , OT's :

Value of all above parameters be kept as three fourth of values specified at 2.1.2.4 above.

2.1.2.6 DUCTING FOR ETAC system and VENTILATION System (normal operation) in Basement :

Value of all above parameters be kept as 1.5 times of values specified at 2.1.2.4 above.

2.2 RECOMMENDED COOLING DEMAND DENSITIES

Following table from ASHRAE GRP 158, Load Calculation Manual (Heating & Cooling), provides the recommended cooling demand densities (m^2 /TR) for different building types using air conditioning systems. The requirements given in the table may be used for preliminary calculations. However, final sizing shall be based on the actual heat load calculations.

Example of Building air conditioning load (TR) calculation using the table given below.

To estimate the cooling demand (air conditioning load TR) of an office building having air conditioned area of 1,000 m^2

Using the *Lo values (m^2 /TR) given below in the table for office category building, the estimated total air conditioning load (TR) of the building will be

Preliminary estimated air conditioning load (TR) = area (m^2)/ Cooling demand density (m^2 /TR) = 1000/36

Notes:

‡ Refrigeration loads are for entire application.

Air quantities for heavy manufacturing areas are based on supplementary means to remove excessive heat.

* Air quantities for hospital patient rooms and office buildings (except internal areas) are based on induction (air-water) system.

Refrigeration and air quantities for applications listed in this table of cooling load check figures are based on all-air system and normal outdoor air quantities for ventilation except as noted.

Cooling Demand Densities				
		Refrigeration		
		m ² /Ton‡		
Classifications				
Apartment, High rise				
Auditoriums, Churches, Theatres				
Educational Facilities				
Schools, College, Universities				
Factories	Assembly Areas			
	Light Manufacturing			
	Heavy Manufacturing#			
Hospitals	Patient Rooms*			
	Public Areas			
Hotels, Motels, Dormitories				
Libraries and Museums				
Office Buildings*				
Private Offices*				
Stenographic Department				
Residential				
Shopping Centres, Department Stores and Specialty Shops				
Department Stores	Basement			
	Main Floors			
	Upper Floors			
Dress Shops				
Drug Stores				
Shoe Stores				
Malls				
Refrigeration for Central Heating and Cooling Plant				
Urban Districts				
College Campuses				
Commercial Centres				
Residential Centres				

Source: ASHRAE GRP 158, Load Calculation Manual (Heating & Cooling), Table A1.1- Cooling load Check figures

* Hi values of cooling demand density may be used for existing buildings where building envelope cannot be improved

* Av values may be used for unitary (WT or Split type) units and for AC areas surrounded by non AC area else

* Lo values may be used for new buildings.

2.3 WINDOW TYPE A.C.

APPLICATIONS:

Window A.C. are available in standard rating of 1, 1.5, 2 TR these are provided where-

- (i) Window for fixing the AC is available or necessary opening in wall is provided for the purpose.
- (ii) Sound level of up to 50 dB inside the room is acceptable.
- (iii) These types of A.C.s are efficient & easy to maintain as compared to split A.C.
- (iv) BEE star rated WTACs are available. As far as possible 5 star rated A.C. may be provided in all new installation for conserving electrical energy.

INSTALLATION:

- (i) While installing the A.C care be take that WTAC is not provided at back of sitting/ chair in room.
- (ii) Standard A.C are provided with control plate and wire at right side of A.C (as seen from front) hence power outlet points should be provide at right side of window etc.
- (iii) Standard installation procedures, as given by the manufacturers, may be followed.

2.4 SPLIT TYPE A.C.**APPLICATIONS:**

- (i) Where window for installation of WTAC is not available, Split Type AC are planned.
- (ii) Almost Silent (Low dB level) operation of A.C is important, considering VIP rooms, conference rooms, etc.

INSTALLATION

- i) Wherever split A.C. are planned in the new buildings, necessary openings in wall may be provided by with use of 75 mm PVC pipe sleeves at suitable locations for taking refrigerant pipes and cable to outdoor unit, so as to avoid unnecessary cutting/ damage to walls at a later stage. The slope of sleeve of PVC pipe should be towards exterior to avoid seepage of water into the room. This opening should be sealed properly after installation to avoid entry of vermin and rain water.
- ii) For condensate drain, 40 mm PVC/ HDPE pipe be also provided and taken to nearest drain or up to the stack for collection & disposal of condensate. The slope of such pipe also should be downwards. As far as possible, joints should be avoided in this pipe.
- iii) The length of connecting refrigerant pipes between outdoor and indoor unit be kept to minimum feasible at site. However it should not exceed 9 m , as the efficiency of the unit gets severely affected on increase of distance. The refrigerant pipes should be taken along the walls/ columns etc. duly clamped to their surface by saddles. If walls etc. are not available, tray be used to support the refrigerant pipes. Where bending of

refrigerant pipes is required, proper pipe bending tool should be used to avoid pinching of pipes.

- iv) The refrigerant pipes should be properly insulated as per the recommendations of the manufacturer of split type AC units. The insulation over refrigerant pipes be examined once in a year and in case of any deficiency/ defect the same may be replaced.

2.5 VRV/ VRF SYSTEM:

In a generalising definition, Variable refrigerant flow (VRF) can be explained as a multiple Split Air-conditioning system using principle of control of flow/ quantity of refrigerant through the Indoor Unit to control the cooling/ heating effect. VRF system uses refrigerant as the cooling and heating medium. This refrigerant is compressed and liquefied by a single outdoor condensing unit (ODU), and is circulated within the building through copper refrigerant pipes to multiple fan-coil units (FCUs) called the IDUs(Indoor Units).

VRF ODUs are typically provided with rectifier-inverter power system, which provided a Variable Voltage & Variable Frequency (V3F) supply to compressor motor, in order to support variable speed. This in turn provides variable refrigerant flow through the refrigerant lines meeting the demand of cooling/ heating. The speed of the motor is controlled through a feedback system sensing the refrigeration demand from the IDUs.

VRFs come in two system format, two pipe and three pipe systems. In a 2 pipe system all of the zones must either be all in cooling or all in heating. A three pipe Heat Recovery (HR) systems has the ability to heat certain zones while others require cooling. In this case the heat extracted from the zone requiring cooling is put to use in the zone requiring heating. This is made possible because the heating units are functioning as a condenser.

APPLICATIONS:

These systems are basically extensions of split type A.C's and are much less efficient as compared to central A.C. plant hence should not be provided except in following cases-

- i. In the existing building, requiring central AC but the space for providing AC plant, height of ceiling for ducting, water supply for chilled water based AC plant, is not available.
- ii. It is not possible to provide central A.C. plant and run the chilled water lines up to cool the rooms with fan coil units to cool the rooms.

Such system is normally provided where high diversity in demand is available i.e. small Guest houses, small hotels, small offices, Art Galleries, etc.

A comparison of the VRF/ VRV systems with the Central Chilled water system was got done. Also recommendations of BEE were taken in case of a large building AC requirement. It is added below for making decision.

S. No.	Points	VRF AC	Chilled Water based AC	Remarks
1	Peak Power Demand	1.6KW/TR peak. (Efficiency drastically reduces at high ambient as Delhi summers)	1.3KW/TR Peak. (IKW/TR<0.6 now for chilling units.)	Higher size & cost of Power Supply Capital Equipment like Transformers etc. & thus higher Cu losses (recurring) in VRF system.
2	Annual Power Consumption	1.15 to 1.20	1	Annually extra expenditure of 15 to 20% in electricity bills in VRF system.
3	Security & Safety Of Equipment & System	Copper piping on terrace & in building	MS piping	VRF system equipments/ materials prone to theft & damage by miscreants & monkeys.
4	Terrace Space	Almost 80% terrace is used for ODUs & Cu pipe & power cables	Only Cooling Towers need to be installed at terrace.	With VRF loss of space for SPV Generation to meet the Green Building Norms. Problem of cleaning terrace & loss of water proofing also occurs over time.
5	Water Scarcity	No water required	Regular Supply of Water required for condenser cooling	Major advantage in VRF system but, now STPs are generating water for meeting up to 75% of AC Plant demand. Water drift losses also being reduced by use of Geothermal Energy.
6	Air Quality of Conditioned space	RH ,Co ₂ , Bacteria, dust & other pollutants Control only to very limited extent.	Full control	Sick building syndrome is taken care of in Water based system with AHUs and demand based fresh air supply.
7	Service / attending to faults	Personnel have to go into the room. Problems of condensate dripping in rooms.	Such problems limited only in AHUs.	No disturbance to officers in water based system.
8	Long Term Benefits	Maintenance Expensive	Low Cost Maintenance	
9	Fire Safety	Refrigerant in system goes to all areas in building and is combustible at high temperatures, releasing toxic products of combustion.	Only water in AHUs and Air only in rooms through ducts. Refrigerant is limited to only within the Chilling Units.	Water based system is safer.
10	Life	10 Years	15-20 Years	Longer Life in water based system. In areas with proximity to sewage nallahs, the life is drastically reduced due to corrosion of Copper
11	Applications	Home or Small office with variable occupancy. More cost effective in room redundancy cases.	Large office, continuously large air conditioning loads, proper controlled conditioning of space.	Even with AHUs individual room temperature control possible with Variable Air Volume Valves.

12	ARI Certification	No	Yes	Standards applicable and products certified in case of water based Chilling machines.
----	-------------------	----	-----	---

Comparison between VRF/VRV System with Central Chilled Water System:

S.No	Variable Refrigerant Flow (VRF) system	Chiller based Air conditioners
1.	Power consumption in VRF system ranges up to 1.6 KW/TR of refrigeration.	Power consumption in this system range up to 1.3 KW/TR of refrigeration.
2.	Most of the VRF units are designed at an ambient temperature of 36°C, and so its use would not be suitable if the system is used in places with hotter temperature.	Customization in design of the Chiller system can be done with respect to ambient temperature.
3.	If the system is used at hotter place, then system de-rates.	This is not the case in chiller based system.
4.	It requires more space for its outdoor unit as maximum size of outdoor unit available is 60 hp, so a large no. of outdoor units would be required to fulfill the requirement of 3500-4000 TR	It can be managed by a single plant room.
5.	Its design is very complex	Its design is comparatively less complex.
6.	Its CoP (Coefficient of Performance) varies from 3 to 4.2; a higher CoP implies greater efficiency	Its CoP varies from 5.4 (for 750 TR chiller) to 6.3 (for 1000 TR chiller)
7.	Its part load efficiency is good if used at more than 50 % rated capacity	Its part load efficiency is good even at one – third of the rated capacity.

Source: Information by Bureau of Energy Efficiency while designing A.C. system of one of the largest CPWD Projects.

“VRF systems are best as alternative to room (window or split) air conditioner.

For an installation of 3500-4000 TR, as is proposed for the new Supreme Court building, a central chiller- based system will be more efficient than VRF system. In order to maintain the peak efficiency of the chiller based system, when the load is less than peak load, the following design strategy could be considered:

a. Installation of 3 or 4 modules of 750-1000 TR capacity: Each chiller could serve a different part of the building, and so air conditioning could be managed in different area accordingly to usage requirements. Further each chiller can deliver near –peak efficiency delivery upto about 1/3rd of its rated capacity, and so high efficiency can be delivered even with large variations due to usage variance and climatic conditions.

b. Appropriate control systems could be installed to manage cooling in various kinds of usage areas: Independent AHUs for common areas, and independent

fan coil units for rooms and chambers can provide the necessary level of control to ensure that appropriate cooling as per needs, is provided in different spaces within the complex. This will ensure that the overall demand for cooling is managed, and waste full air conditioning can be minimized.”

2.6. PACKAGED TYPE UNITS

2.6.1 Application

These are best suited for air conditioning of areas up to about 450 sqm (about 30 TR A/C load) located adjacent to each other. Beyond this central plant is generally more economical. These are generally available in 5 TR, 7.5 TR, 10 TR , 15 TR **and 20 TR** capacities. The components are housed in a vertical cabinet. These units can be used singly or in multiples of two/ three units.

2.6.2 Type: A packaged unit can be either water cooled or air cooled.

2.6.3 System components-

- i) A water cooled packaged type unit includes the following basic components:
 - (a) Refrigeration compressor
 - (b) Condenser (water cooled)
 - (c) Evaporator
 - (d) Expansion Valve
 - (e) Refrigerant piping along with controls
 - (f) Supply air blower
 - (g) Filters

Condenser in this system is cooled by a system of cooling tower(s), condenser water pumps & connecting condenser water piping.

- ii) An air-cooled packaged unit is in two portions-Indoor unit and outdoor unit. Compressor, Evaporator, Expansion Valve, SA blower & filters are in indoor unit & condenser along with condenser fan is in outdoor unit. Here condenser is cooled by a propeller fan.

2.7 CENTRAL PLANTS

For capacities larger than **100 TR**, it is generally economical to go in for central plants.

2.7.1 System components-

A central air-conditioning system may comprise of following basic components.

- i) Refrigeration unit (Central plant) comprising of compressor, condenser, expansion valve, evaporator & interconnecting refrigerant piping.
- ii) Hot water generators.
- iii) Cooling towers.
- iv) Condenser water pumps
- v) Chilled / Hot water pumps (Primary and Secondary System as applicable).

- vi) Chilled / Hot water piping (required in central chilled water system).
- vii) Condenser water piping.
- viii) Air handling units (AHUs) comprising of supply air blower, cooling coil and/ or heating coil, humidification system (wherever specified), & filters (the room in which AHU is installed is called weather maker room).
- ix) Air distribution system comprising of ducting, **variable air volume (VAV) valves, fire control dampers**, grilles & diffusers.
- x) **Treated fresh air system (TFA), Free Cooling System,**
- xi) Demand Control Ventilation System.**
- xii) Heat Recovery Wheel / Heat recovery pipe/any other measure for energy conservation for areas, requiring high fresh air intake.**
- xiii) Electric power supply & distribution.**
- xiv) Controls & control wiring.

Depending upon the application and design requirements, which the air-conditioning system must meet, some of above components shall have to be arranged in certain sequence to condition the air.

2.7.2 Type of Central plants

Refrigeration unit (Central plants) as mentioned under para 2.7.1 (i) above may be of DX type or chilled water type as per following details:-

2.7.2.1 DX (Direct Expansion) type central plant:-

- i) In this type of central plant the evaporator(s) component of the central plant is located in the air handling unit(s) & works there as DX-type cooling coil. The components-chiller, chilled water pumps & chilled water piping are, therefore, not required in this type of plant.
- ii) This type of plant is commonly installed under following circumstances-
 - a) When the air conditioning load is not very large say up to 100 TR & space for plant room is available adjacent to AHU room(s).
 - b) When the temperature to be maintained in air conditioning space is below 21⁰C, the use of DX type plant becomes technically essential due to the limiting factors of evaporation temperature of the refrigerant & the temperature difference between the primary & secondary cooling medium.

2.7.2.2 Chilled water type central plant

- i) The chilled water type central plant becomes necessary when a number of smaller zones require air-conditioning. In this case, the chilled water is generated in a centrally located plant room and is piped to various AHUs, which in turn are individually located near the space they air-condition.
- ii) The BHP per tonne of refrigeration in the case of chilled water system is high compared to the direct expansion system.

2.7.2.3 Depending upon the type of compressor used, Central air conditioning plants are of three types.

- i) Reciprocating type central air conditioning plant.

These plant use reciprocating compressor. These are available in capacities ranging from 30 TR to 110 TR. However these are slowly being discontinued due to poor compressor efficiency and being replaced with scroll & screw type compressors.

- ii) Screw type central air conditioning plant.

These plants use screw type compressors. These are generally used in capacities ranging from **80 TR and up to 400 TR at present.**

- iii) Centrifugal type central air conditioning plant.

These plants use centrifugal compressors. Centrifugal compressors are not suitable for circulating and expanding the liquid refrigerant in remote heat exchange surface. They are, therefore, used only to chill water/ brine for circulation through remote heat exchanger surface (AHU coils).

2.7.2.4 System Design & plant selection

- i) The system design shall be done after detailed heat load calculations considering the outside and inside design conditions, ventilation requirements and internal loads. The plant selection shall be made on the basis of the calculated peak load, load diversity, partial load requirements and standby capacity. Normally the size of chillers is so chosen that at least two chillers, each of 50% of full load requirement are provided. In case of very large requirements, sometimes the architectural & structural limitations may dictate the compulsions to limit the size of individual chillers to smaller capacity. The standby capacity in turn will depend upon the number of hours of operation of the plant per day, relative importance of the installation and functional requirements. Normally for 12 hrs operation of plant one number additional unit of the same capacity as standby may be provided. For 24 hrs operation of plant, 100% standby may be provided.
- ii) The type, capacity and quantities of the various components of the system shall then have to be worked out and specified.
- iii) It is also a good practice to simulate cost of operation of the plant by considering different capacity of chillers for the type of applications. It is established that by properly selecting the chiller size we can save up to 10 % in operational cost.
- iv) The various components of the system shall be so selected as to match each other under operating conditions of full load as well as anticipated partial loads.
- v) Having selecting the size of chillers it may be decided whether single circuit or dual circuit chiller be provided.
- vi) The overall dimensions of various equipments in the system shall be suitable for installation in the available space. The permissible loading of the building structure, acceptable noise level and aesthetics should also be considered.

- vii) Areas with different requirements of fresh air, degree of filtration and/ or operating hours shall need different and independent AHUs.
- viii) From the fire safety point of view, storage areas of combustible articles such as film stores and explosives shall not be served by the AHUs, which are serving other areas. Other fire precautions as per National Building Code, local municipal byelaws and other statutory requirements shall be complied with.
- ix) For 24 hrs A/C areas & where the secondary chilled water pumps are provided, to save energy, the secondary pumps may be provided with variable speed drive (VSD) to regulate water flow as per load requirement.
- x) For 100% (Fresh air) AHUs requiring 24 hrs. operation, variable speed drive (VSD) may be provided to regulate the flow of dehumidified air as per load requirement.
- xi) In case the cooling is done by positioning fan coil units (FCUs) within the conditioned spaces and circulated chilled water through them, it should also be supplemented by circulating conditioned air through 100 % FA AHU (Treated Fresh Air AHU) by a network of ducting, grills and diffusers to the conditioned spaces for better comfort conditions in terms of ventilation, & humidity control and Oxygen requirements.
- xii) For areas like operation theatre, animal house and where specifically required functionally, AHUs with 100% fresh air shall be used. The return/ used air in such cases shall be exhausted to atmosphere by installing a suitable exhaust air system. This exhaust air system shall consist of single skin blower section and a filter section. This exhaust air system may be ceiling suspended/ floor mounted as per the site availability.
- xiii) In 100% fresh air areas and areas having high occupancy such as lecture theatres, auditoria, etc., requiring high volume of fresh air, pre-cooling of fresh air be done by providing Heat Recovery Wheel.
- xiv) In addition to controlling the inside temperature it is necessary to control the concentration limit of various pollutants as per ISHRAE handbook table no. 29, which are listed below. This is done by providing Demand Control Ventilation System using sensors for detecting the concentration and varying the Fresh Air Supply through motorised dampers.

Contaminant	Concentration	Ppm	Exposure time
Carbon dioxide*	1.8 g/cum.	1000	Continuous
Carbon monoxide	55 mg/cum.	50	8 hr
Chlordane	55 µg/cum.	0.0003	Continuous
Ozone	100µg/cum.	0.05	Continuous
Radon**	0.027/WL	-	Annual Average
Nitrogen dioxide	9 mg/cum.	5	Continuous

Sulphur dioxide	13 mg/cum.	5	
Total Suspended Particulates = 100 µg/m/cum. 1 hrs * Threshold value - 600ppm (NIOSH) ** 3200 piococuries			

2.8 CENTRAL HEATING SYSTEM

2.8.1 A central heating system is a means of heating the air in a conditioned space with or without humidification. Various methods used for central heating are:-

- i) The most common method of heating is with the help of a hot water generator. This is achieved by circulating the hot water so generated either through: -
 - a) Heat convectors or radiators positioned in the conditioned spaces, or
 - b) Heating coils of AHUs and circulating the heated air through the conditioned spaces, analogous to the central chilled water air conditioning system.
- ii) Reverse cycle by providing changeover valves in the chilled and condenser water piping.

Use of Strip Heaters is now discontinued due to fire hazard.

2.8.2 Central Heating through Hot Water Generators

- i) General Description of System

The hot water generator be electrically operated. Coal & Oil fired hot water generators are now not in use due to very low energy efficiency and pollution considerations.

The hot water so generated is piped through either heat convectors/ radiators or AHUs, depending upon the system followed. Heat convectors/ radiators are used where no humidity control is required. In order to provide better comfort conditions, this type of heating can be supplemented with preheated fresh air circulated through AHUs and ducts. The central heating scheme can also be designed along with the central chilled water air-conditioning scheme where cooling during summer and heating during winter are required in one of following manners:

- a) Laying separate pipe lines for chilled and hot water flow from A.C. plant room to AHUs. Here AHUs will have separate cooling and heating coils. For humidity control in monsoon re-heat coils in the main initial section of S.A. duct shall be provided.
- b) In case of space constraints in respect to laying of separate pipe lines & cooling, heating coils, same water lines and heat transfer coils may be designed to carry chilled water during summer/ monsoon for cooling and hot water during winter for heating. In this case however humidity control by reheat shall not be possible, as strip heaters used earlier are not allowed due to Fire Protection consideration.

ii) System Component :

A complete central heating system may include the following components :

- a) Hot water generator,
- b) Hot water pump,
- c) Hot water piping,
- d) Convector/ radiator
- e) Heat transfer units (AHUs), variable air volume (VAV) valves, fire control dampers, grills & diffusers
- f) Treated fresh air system (TFA),
- g) Demand Control Ventilation System.
- h) Heat Recover Wheel.
- i) Air filters,
- j) Air distribution system,
- k) Controls and control wiring and,
- l) Power supply control and distribution arrangement.

Some or all of the above components shall have to be arranged in a proper sequence to condition the air.

iii) System Design and plant selection:

It shall be done as per para 2.7.2.4 above.

2.8.3 Central Heating through electric strip heaters :

Strip heaters used earlier are not allowed due to Fire Protection consideration.

2.8.4 Central Heating through Reverse Cycle :

i) General Description.

- a) The chilled water air-conditioning system which is used for cooling in summer can also be used for heating in winter by providing additional valves & piping for interchanging the condenser water & chilled water flow circuits.
- b) During summer when cooling is required, the chilled water plant is operated as a conventional system with the chilled water being circulated through the cooling coils of the AHUs and FCUs to cool and dehumidify areas and condenser water being circulated through the cooling tower.
- c) During winter, when heating is required, the condenser water is circulated through the cooling coils of AHUs and FCUs. The warm condenser water heats the air passing over AHU/ FCU cooling coils and gets cooled in the process. The cooled condenser water is then circulated through the condenser to condense the refrigerant vapour and it gets heated up in the process. The cooling coils thus perform the function of the cooling tower. The chilled water from the chiller is circulated through the cooling tower. The temperature of chilled water being lower than the ambient air, the chilled water gets heated by the ambient air. The chilled water from the cooling tower is then circulated through the chiller to evaporate the refrigerant & it gets cooled in the process. The cooled water is then circulated through the cooling tower. The cooling tower performs the function of the cooling coil. This winter heating is known as reverse cycle heating and can be accomplished by interconnection of chilled water and condenser water supply and return headers through change over valves.

d) **This system can be used in places where winter ambient temperature is more than 7.2⁰C (W.B) & Quality of water shall have hardness less than 60 PPM.**

ii) Limitations :

- a) The reverse cycle heating cannot be resorted to when the outside wet bulb temperature drops below 7.2⁰C.
- b) Further, if the quality of condenser water is bad, circulation of condenser water through the cooling coils may foul the tubes of the cooling coil and may also lead to scale formation inside the tubes of the cooling coils. **Hence this system is used where hardness of water is less than 60 PPM.**

2.8.5 Central Heating through Heat Pumps:

For cold areas having RH below 55% throughout the year, heat pumps may be used, if economical.

2.9 Mechanical Ventilation (For Non Air Conditioned Areas)

2.9.1 Ventilation

Ventilation is the process of changing air in an enclosed space. A proportion of the air in the space should be continuously withdrawn and replaced by fresh air drawn from outside to maintain the required level of air purity. Ventilation is required to control the following:

- a) Oxygen Content — Prevent depletion of the oxygen content of the air;
- b) Carbon dioxide and Moisture — Prevent undue accumulation;
- c) Contaminants — Prevent undue rise in concentration of body odours and other contaminants such as tobacco smoke;
- d) Bacteria — Oxidize colonies of bacteria and fungus to prevent their proliferation.
- e) Heat — Remove body heat, heat generated by electrical & mechanical equipment, solar heat gains through walls & glass, etc.

Mechanical ventilation is one of several forms of ventilation options available. It usually consists of fans, filters, ducts, air diffusers and outlets for air distribution within the building. It may include either mechanical exhaust system or exhaust can occur through natural means.

Natural ventilation and natural exhaust are also options. The scope of this section is therefore restricted to mechanical ventilation.

2.9.2 Design Considerations.

Following considerations provide details regarding the various parameters that affect the type of ventilation system selected for a particular application, and the sizing of the ventilation plant:

2.9.2.1 National Building Code of India 2005 specified the ventilation requirement as per following table:

Ventilation Requirement for various areas in various buildings :

S.No.	Application	Air Change per hour
1.	Assembly Rooms	4-8
2.	Bank/building societies	4-8
3.	Bathrooms	6-10
4.	Bedrooms	2-4
5.	Canteens	8-12
6.	Cinemas and theatres	10-15
7.	Club rooms	12, <i>Min</i>
8.	Conference rooms	8-12
9.	Corridors	5-10
10.	Dance halls	12, <i>Min</i>
11.	Engine Room	15-30
12.	Entrance halls	3-5
13.	Garages	6-8
14.	Glass Houses	25-60
15.	Gymnasium	6, <i>Min</i>
16.	Hospital –sterilizing	15-25
17.	Hospital –ward	6-8
18.	Hospital domestic	15-20
19.	Laboratories	6-15
20.	Laundries	10-30
21.	Lavatories	6-15
22.	Lecture theatres	5-8
23.	Libraries	3-5
24.	Living rooms	3-6
25.	Offices	6-10
26.	Photo and X- ray dark room	10-15

27.	Recording control rooms	15-25
28.	Restaurants	8-12
29.	School room	5-7
30.	Shops and supermarkets	8-15
31.	Shower baths	15-20
32.	Stores and Warehouses	3-6
33.	Swimming Bath	10-15
34.	Toilets	6-10

Note: - The ventilation rates may be increased by 50 percent where heavy smoking occurs or if the room is below ground.

2.9.2.2 CMM required for ventilation system is thus calculated Based on the volume of the room and from the above table as-

$$\text{CMM} = \frac{(\text{no. of air changes/ hour}) \times (\text{volume in cu. m of space to be ventilated})}{60}$$

2.9.2.3 CMM required for Pressurisation of lifts lobby, lift shaft, stair case shaft is calculated from closed door as well as opened door area as-

- i) Leakage area = total nos. of doors x gap in doors (normally taken as 2 mm) x perimeter of doors.
- ii) Leakage form closed door = 0.821 x leakage area x pressure difference.
- iii) Opened door leakage = door area x no. of opened door (normally considered 1 door) x velocity (normally considered as 0.76 m / sec) of air.
- iv) Total air leakage = closed door + opened door leakage.
- v) Add 10% safety factor/ duct leakage etc., which will give CMM required.

2.9.2.4 CMM required for Basement Parking Ventilation

- i) Divide the basement in zones of area not exceeding 3000 sqm. in case sprinkler system is provided in basement, if not, then not exceeding else 750 sqm.
- ii) For each zone separate set of supply air fans and exhaust air fans shall be provided. Supply air fans shall not be required in areas in zone near Ramps or zone with natural ventilation, however sufficiency may be examined.
- iii) Minimum 12 air changes/hrs. are required to be provided.

- iv) Calculate the CMM required for each Zone as per 2.9.2.2.
- v) The recommended ventilation rate will ensure that the CO level will maintained within 29 mg/m³ with peak level not to exceed 137 mg/m³.

2.9.2.5 Calculation of Fan Static-

- i) Pressurization system for lifts lobby, lift shaft, stair case shaft -
As per NBC part – 5 fire and light safety the following pressure are to be maintained for various shafts in high-rise building more than 25 mtr. in height-

Building Height	Pressure Difference	
	Reduce Operation (Stage 1 of a 2 Stage system)(Pa)	Emergency operation (Stage 2 of a 2 stage or single stage system)(Pa)
Less than 15 m	8	50
15 m or above	15	50

- ii) If possible the same levels shall be used for lobbies and corridors, but level slightly lower may be used for these spaces if desired. The difference in pressurization levels between staircase and lobbies (for corridors) shall not be greater than 5 Pa.
- iii) For Basement Parking Ventilation the static can be calculated by duct friction method using a ductolator.

2.9.2.6 Selection & Installation of Fans :

Having defined the fan CMM & static to be developed, the fan is selected on basis of following criterion-

- i) Pressurization system for lifts lobby, lift shaft, stair case shaft :
 - (a) Fans are normally installed at terrace and are to be enclosed in GI housing.
 - (b) Some duct work is required for connecting up to the shaft.
 - (c) These fans shall be operated automatically in case of fire on signal from IBMS or directly from Fire Control Panel of AFAS. Panels for these fans can be provided in lifts machine rooms. Auto manual switch is required to be provided to facilitate local testing.
- ii) Basement car parking ventilation :
 - (a) Normally centrifugal fan are provided in fan room in basement. In case fan room is not available, ceiling mounted axial fans may be provide.
 - (b) All exhaust fan provided for the scheme, shall be fire rated for 900°C for 2 hrs.
 - (c) Normal ventilation fans for min. 12 air change/ hrs are kept on during working hours. However CO₂ sensor may be provide which will continuously monitor the air quality and operate the normal fans only when required and there by conserve energy.

- (d) For each zone, zonal electrical panel is required to be provided which shall get the signal from fire alarm panel to activate the fans in case of fire to achieve 30 air changes per hr.
- (e) While selecting the fans noise level of fans may be kept under consideration to make sure that the noise level is kept below 80 decimal at all times except in case of fire.
- (f) Selection of Fan type for Ventilation System

The characteristics and applications of fans & the efficiencies of various type of fans are tabulated below for selection of fans-

Centrifugal Fans			
Type	Characteristics	Typical Applications	Efficiency (%)
Radial	High pressure, medium flow, efficiency close to tube-axial fans, power increases continuously	Various industrial applications, suitable for dust laden, moist air/ gases	72–79
Forward-curved blades	Medium pressure, high flow, dip in pressure curve, efficiency higher than radial fans, power rises continuously	Low pressure HVAC, packaged units, suitable for clean and dust laden air/ gases	60–65
Backward curved blades	High pressure, high flow, High efficiency, power reduces as flow increases beyond point of highest efficiency	HVAC, various industrial applications forced draft fans, etc.	79–83
Airfoil type	Same as backward curved type, highest efficiency	Same as backward curved, but for clean air applications	79–83
Axial Flow Fans			
Type	Characteristics	Typical Applications	Efficiency (%)
Propeller	Low pressure, high flow, low efficiency, peak efficiency close to point of free air delivery (zero static pressure)	Air-circulation, ventilation, exhausts.	45–50
Tube-axial	Medium pressure, high flow, higher efficiency than propeller type, dip in pressure-flow curve before peak pressure point.	HVAC, drying ovens, exhaust Systems	67–72
Vane-axial	High pressure, medium flow, dip in pressure-flow curve, use of guide vanes improves Efficiency exhausts	High pressure applications including HVAC systems	78–85

2.10 ETAC Plants

A mechanical ventilation system is a means to dispense of unwanted odours, fumes and heat content to maintain freshness in the ventilated space. When this is supplemented with an air washer for lowering dry bulb temperature and

providing better comfort conditions in dry climates, the system is known as Evaporative Type Air Cooling (ETAC).

2.10.1 Design Considerations

- (i) The climatic zone in which the building is located is a major consideration. An important distinction that must be made is between hot dry and warm-moist conditions. Hot-dry work situations occur around furnaces, forges, metal-extruding and rolling mills, glass forming machines, and so forth.
- (ii) Typical warm-moist operations are found in textile mills, laundries, dye houses, and deep mines where water is used extensively for dust control. Warm-moist conditions are more hazardous than the hot-dry conditions.
- (iii) Siting (and orientation) of the building is also an important factor. Solar heat gain and high outside temperature increase the load significantly. How significantly depends, on the magnitude of these gains particularly in relation to other gains for example the internal load.
- (iv) The comfort level required is another consideration. In many cases, comfort levels (as understood in the context of Residential Buildings, Commercial Blocks, Office Establishments) cannot be achieved at all and therefore, what is often aimed at will be 'acceptable working conditions' rather than 'comfort'.
- (v) Evaporative cooling units (air washers) should be located preferably on summer-windward side. They should be painted white or with reflective coating or thermally insulated, so as to minimize solar heat absorption.
- (vi) In locating the units, care should be taken to ensure that their noise level will not be objectionable to the neighbours. Appropriate acoustic treatment should be considered, if the noise levels cannot be kept down to permissible limits.
- (vii) Exhaust air devices, preferably to leeward and overhead side may be provided for effective movement of air.
- (viii) In the case of large installations it is advisable to have a separate isolated equipment room if possible.
- (ix) The equipment room should be adequately dimensioned keeping in view the need to provide required movement space for personnel, space for entry and exit of ducts, the need to accommodate air intakes and discharge, operation, maintenance and service requirements.
- (x) Arrangements for draining the floors shall be provided. The trap in floor drain shall provide a water seal between the equipment room and the drain line. Water proofing shall be provided for floor slabs of equipment rooms housing, evaporative cooling units.
- (xi) Wherever necessary, acoustic treatment should be provided in plant room space to prevent noise transmission to adjacent occupied areas.
- (xii) In case the equipment is located in basement, equipment movement route shall be planned to facilitate future replacement and maintenance. Service ramps or hatch in ground floor slab should be provided in such cases. Also arrangements for floor draining should be provided.

- (xiii) In the case of large and multi-storied buildings, independent Ventilation/Air Washer Units should be provided for each floor. The area to be served by the air-handling unit should be decided depending upon the provision of fire protection measures adopted. The Units should preferably be located vertically one above the other to simplify location of pipe shafts, cable shafts, drainers.

2.10.2 General Description of System

- i) The air in the ventilated space is exhausted into the atmosphere. This air is made up by injecting fresh air from outside. In a simple ventilation system, this fresh air (makeup air) is supplied untreated with the help of blower and duct network. However, in ETAC system, most suitable in a dry climate, this fresh air (make up air) is treated in an air washer before its supply to the ventilated space for providing better comfort conditions.
- ii) The air washer is basically a spray chamber where the air and the cooling medium are brought into contact with each other. The air is drawn through the spray chamber by means of a fan and water is sprayed by means of a water pump & piping network. Such a spray chamber, complete with water collecting tank, eliminator plates, inlet louvers and other auxiliary equipments are known as air washers. During the course of flow through the air washer, the air may get cooled & humidified or cooled & dehumidified or heated & humidified depending on the temperature of spray water as is given hereunder:-
 - a) When the water used in the spray is simply re-circulated, the air passing through air washer will get cooled & humidified.
 - b) When the water used in the spray is chilled (by some external devise) & its temperature is higher than the dew point temperature of entering air, the air on passing through air washer will get cooled & humidified.
 - c) When the water used in the spray is chilled (by some external devise) & its temperature is lower than the dew point temperature of entering air, the air on passing through air washer will get cooled & dehumidified.
 - d) When the water used in the spray is heated (by some external devise), the air on passing through air washer will get heated & humidified.

The air washers are usually constructed in two different lengths of 2.75 mtrs long and 4.25 mtrs long. The 2.75 mtrs long air washers are equipped with two banks of spray opposing each other. These air washers are used for humidification or dehumidification purpose. The 4.25 mtrs long air washers are usually with three banks of sprays. These air washers are generally used for certain special applications where high percentage of saturation of air is required.

- iii) Where ex-filtration of air from the ventilated space is to be prevented from reaching the other areas, a slight negative pressure is to be maintained in the ventilated space. This can be achieved by keeping the exhaust air quantity slightly higher than supply air (make up air) quantity. This is especially necessary where odours and fumes are required to be prevented from reaching other areas.

2.10.3 System Components

- i) A complete mechanical ventilation system with air washers includes the following components: -
 - a) Means of exhausting and / or injecting the air,
 - b) Air filters,
 - c) Air distribution,
 - d) Air washer,
 - e) Water spray pump, nozzles & piping network,
 - f) Controls and control wiring, and
 - g) Power supply and distribution arrangement.
- ii) Depending upon the application and design requirements, which the mechanical ventilation / ETAC system must meet, some or all of the above components shall have to be arranged in a certain sequence to condition the air.

2.10.4 System Design

- i) The system design shall be done by first deciding upon the number of air changes per hour required to be maintained in the space. The capacity of the exhausting and/or the injecting equipments can then be worked out on the basis of the volume of the space and the number of air changes required per hour.
- ii) The recommended number of air changes per hour for various applications are as given at 2.9.2.1.
- iii) The other requirements shall be as given under paras 2.10.1 to 2.10.3
- iv) A brief system design for some of the applications is given below:
 - a) Kitchens:

The exhaust system should take care of all the heat, smoke and odours produced during the cooking process and also maintain a hygienic atmosphere within the kitchen. The exhaust of air should be done through hoods equipped with grease filters, duct network and a exhaust blower. The hood should be of such a size as to capture, as nearly as possible, all the above pollutants produced in the cooking process and to contain them until the fan can exhaust them. Grease filters are used with the hood to protect the exhaust system. The exhaust air is made up by using fresh air from outside with the help of a blower and a duct network. The makeup air can be supplied untreated, or treated in an air washer so that slight negative pressure is maintained in the kitchen to prevent exfiltration of the pollutants to the public areas. This is achieved by exhausting approximately 10% more air than the supply air quantity. Air curtains can also be used at entry / exit points of the kitchen to prevent the kitchen pollutants from going into the public areas.
 - b) Toilets:

Where the toilets are scattered and located at different places, a local exhaust system with propeller type exhaust fans mounted on the toilet walls exposed to the atmosphere is recommended. However, in multi-storied buildings, where

the toilets are generally located one above the other in the various floors, the toilet shaft can be used for exhausting the air through sheet metal ducts with a centrifugal fan installed on the rooftop.

c) Car Parks

In the case of basement floor parking areas, a push-pull arrangement of ventilation can be used. One set of axial flow fans can push fresh air into the basement area and another similar set can evacuate the fume-laden air.

d) Mechanical Plant Rooms:

In the case of air conditioning plant rooms, generator rooms, substation, boiler room etc., located in the building basement, a push-pull arrangement of ventilation as mentioned at (c) above may be used.

e) Designated Smoking Rooms

To curb any movement of contaminated air from the smoking zone to non-smoking areas, it should be ensured that the smoking zone operates at a negative pressure in comparison with the surrounding non-smoking areas.

Ventilation system of the smoking zone should be separate from that of the non-smoking areas. To maintain the required indoor air quality standards in the smoking zones, the smoking zones should have higher ventilation rates than non-smoking areas and should be designed for at least 60 cubic feet per minute per person.

The contaminated air from the smoking zone should be exhausted directly to the outdoors. It should be ensured that there is no recirculation of this air contaminated with tobacco smoke, to the non-smoking zones of the building.

If the smoking zone is mechanically ventilated, it should have an air circulation rate of not less than 30 air changes per hour.

2.11 COLD ROOMS

A cold storage system is a means of achieving and maintaining low temperature conditions, with or without humidity control, in an enclosed space. For smaller capacities these can be of factory assembled units such as deep freezers, bottle coolers and walk-in-coolers. For larger capacities and to meet the specific requirements, site assembled or built up cold storage systems are resorted to. These General Specifications only cover the latter type, viz., built up cold storage systems.

2.11.1 General Description of the System

i) A cold storage system involves refrigeration equipment, with or without humidity control equipment depending upon the application. Where humidity control is required, dehumidifiers or driers as are more commonly called, are used, especially in very low temperature applications. In normal cases, it should be possible to achieve the required humidity conditions with the normal refrigeration cycle.

- ii) The conventional method is to provide a product cooler, which is nothing but an evaporator in the refrigeration cycle, within the cold room. Alternatively, conditioned air through AHUs can also be fed to the cold room.
- iii) The cold room has to be properly insulated to reduce the refrigeration load and to maintain the desired inside conditions.

2.11.2 System Components

A built up cold storage system shall include the following components: -

- i) Refrigeration unit comprising of compressor, condenser, expansion valve, evaporator & refrigerant piping,
- ii) Cooling Tower,
- iii) Product Cooler/ AHU,
- iv) Air filtration and distribution,
- v) Piping systems which include refrigerant piping, condenser water piping, hot water/steam piping for defrosting,
- vi) Controls and control wiring,
- vii) Power supply control and distribution arrangement.
- viii) Dehumidifier

Depending upon the application and design requirements, which the cold storage system must meet, some of the above components shall have to be arranged in a certain sequence to give the required conditions.

2.11.3 System Design

- i) The system design shall be done as per para 2.1.2.3. In addition, provision for automatic defrost and disposal of collected water should be made. The selection of the type of defrosting shall be appropriate to the inside conditions.
- ii) Provision shall also be kept for safety alarm bell with high intensity blinking LED to assist any one trapped in the cold room.
- iii) Standby product cooler shall be provided as required.

CHAPTER-3

ARCHITECTURAL AND STRUCTURAL REQUIREMENTS

3.1 SCOPE

This chapter outlines the general guidelines for planning space requirements, equipment location, floor loading & other structural requirements for various types of HVAC systems

3.2 PACKAGED TYPE PLANT

3.2.1 Space Requirements

- i) The floor area requirement for installation of the packaged type plant room shall be as under:
 - a) Single Unit : 3 m X 2.5 m
 - b) Double Units : 3 m X 4 m
 - c) Triple Units : 3 m X 5 m
- ii) Dimensions indicated are clear space requirements. The minimum clear height of the packaged unit room shall be same as that of the space to be air-conditioned to facilitate laying of ducts.

3.2.2 Equipment Location

The packaged type plant room should be adjacent to the space to be air-conditioned.

3.2.3 Floor loading & other structural requirements

- i) Floor loading of the packaged type unit plant room shall not be less than 1200 Kg/ sqm
- ii) The plant room should have a fresh air intake point, fresh water connection and drain point for draining out condensate.

3.3 CENTRAL AIR CONDITIONING PLANT

3.3.1 Space requirements

- i) Space requirement for central air conditioning plant shall be worked out on following basis:
 - Chilling unit
 - a) Reciprocating - 25-30 sq.m per unit (in case of single compressor unit).
 - b) Reciprocating - 40 sq.m. per unit (in case of multi compressor unit)
 - c) Centrifugal/ screw - 40-50 sq.m. per unit
 - d) Centrifugal pump - 8-10 sq.m each pump
 - e) Electrical panel - 20-25 sq.m per chilling unit

- f) Control panel - 20-25 sq.m
- ii) Additional space for circulation shall be taken as 20-25% of the above total space.
- iii) Provision shall also be kept for anticipated future requirements.
- iv) The minimum clear height of the plant room shall be 3.6 m in case of Reciprocating plants and 4.5 m in case of Centrifugal & Screw type plants.
- v) The entrance to A.C. plant room for centrifugal / screw type units shall be through rolling shutter/ suitable door shutters of steel or strong material to take self load having minimum width of 3 m & height not less than 4 m for centrifugal/ screw type units & 3.5 m for reciprocating type units.

3.3.2 Equipment location

The plant room shall have easy accessibility for moving in and out of equipments and shall be well ventilated. The location of the plant room shall also take into consideration the routing of the chilled water and condenser water lines from the plant room. As far as possible the plant room should be in close proximity to the electrical substation, since AC plant is main power load. The plant room shall be preferably located in a separate service building along with the substation. Basements shall be avoided from the fire safety point of view.

3.3.3 Floor loading and other structural requirements

- i) The floor loading of the AC plant shall be 2000 Kg/sq m
- ii) The Plant room should have a fresh water connection & drain trap.

3.4 WEATHER MAKER / AHU ROOMS

3.4.1 Space requirements

- i) Floor area requirement for the AHU room shall be as under:

For AHUs upto 340 CMM	: 4.5 m X 3.5 m
For AHUs between 340 CMM & 680 CMM	: 5.5 m X 4.5 m
- ii) The minimum clear height of the AHU room shall be the same as that of the air-conditioned space to facilitate laying of ducts.

3.4.2 Equipment Location

AHU rooms should be contiguous to the respective areas to be air-conditioned by them. Their location should also take into consideration the feasibility of routing the ducts as well as provision of chilled water lines, water connections for the humidification equipments, fresh air inlet point and drain outlets. In multistoried constructions, the AHUs should be located in a vertical configuration to facilitate laying of chilled water lines. Individual AHUs shall not serve more than one floor from the fire safety point of view. Similarly each fire compartment shall have a separate AHU. Where the AHUs are located in the basement or in any floor below the air-conditioned floors, individual shafts shall

be provided for each AHU from the AHU room for the supply and return air, from the fire safety point of view.

3.4.3 Floor loading and other structural requirements.

- i) The floor loading of AHU room shall be 800 Kg/ sq m
- ii) The doors of the AHU rooms shall be single leaf, air tight having a minimum width of 1.2 m and openable outside. The floor of the AHU room shall slope towards the drain point. For clean room applications and other special requirements the internal finish of the AHU room shall be suitable for these special applications.
- iii) All cutouts in the floor for the pipelines and cable shall be effectively sealed from the fire safety point of view.
- iv) The clear height required to be maintained under the false ceiling shall take into consideration the ducting design and after allowing for the depth of the beams, thickness of the false ceiling including its frame work, recessed light fittings, etc.
- v) The cutouts required in the floor slabs for installing the pipes, ducts and / or cables shall be decided at the initial planning stage and marked in the architectural drawings.
- vi) Requirements for fresh air openings, water and drain in the AHU rooms as well as insulation of exposed roof slabs of conditioned areas as well as AHU room shall also be detailed in the initial planning stage.
- vii) The beams in the ceiling of AHU rooms shall be of low depth to facilitate installing of supply air duct and return air duct.

3.5 COOLING TOWERS

3.5.1 The space occupied by each cooling tower & approximate operating weight for each cooling tower is given as under. In addition there shall be ample open space all around cooling towers for free flow of air.

Capacity	Space requirement per cooling tower	Weight per cooling tower
Upto 40 TR	4m x4m	1000 Kg
50- 100 TR	5m x4m	2500 Kg
125-175 TR	6m x4m	5000 Kg
200-300 TR	7m x4m	6000 Kg
325-400 TR	7m x5m	7500 Kg
425-600 TR	8m x5m	10000 Kg

However the NIT approving authority may give the exact weight after finalizing the makes and getting information from the manufacturers.

3.5.2 Equipment location

These may be located at a well ventilated place either at ground level and contiguous to the plant room, or on the terrace of the building in consultation with the Architect. In case the cooling towers are located on the terrace of the

building, the structural loading of the terrace shall be considered. For this respective columns are to be raised by two feet at the terrace. Cooling towers shall be installed in such a way that their load is transferred directly to the columns for which necessary Mild steel-I sections shall be provided by Air-conditioning contractor. The cooling towers shall be rested on Mild Steel-I sections & not on terrace slab. Sufficient free space shall be left all around for efficient operation of the cooling tower.

3.6 CENTRAL HEATING SYSTEM

3.6.1 Space Requirements

- i) The space requirement shall depend upon the type and capacity of the hot water generator chosen for the work and its overall dimensions.
- ii) Sufficient space shall be left all around the hot water generator for maintenance and operation purpose.
- iii) Space shall also be provided for the auxiliary equipments such as hot water circulating pumps and electrical control panels.
- iv) The minimum clear height of hot water generator room shall be 4.5 m.
- v) Sufficient space should also be provided for the storage of fuel in case of oil fired hot water generator. Though the daily service tank shall be provided within the room, bulk storage tank may be provided outside the buildings, either above or below ground level.
- vi) Use of HSD/ LDO oil fired hot water generator has been discontinued due to pollution & fire safety considerations.
- vii) Space requirement for AHUs shall be as under 3.4.1.

3.6.2 Equipment Location

- i) The hot water generator room shall preferably be located in a separate service building from the fire safety point of view. The room shall have easy accessibility for moving in and out the equipments.
- ii) Electrically operated hot water generator shall preferably be located in close proximity to the electrical substation, especially in the case of large capacity hot water generator.
- iii) The AHU rooms shall be located as under 3.4.2

3.6.3 Structural Requirements

- i) The floor loading of the hot water generator room shall be 2000 Kg/sq m.
- ii) The floor loading of the AHU rooms and other requirements shall be as under 3.4.3

3.7 MECHANICAL VENTILATION/ EVAPORATIVE COOLING SYSTEM

3.7.1 Space Requirement

- i) The space requirement for the equipments, air washers etc., shall be as per the manufacturer's recommendations.
- ii) Space shall also be provided as required for the installation of the pumps along with the air washers.
- iii) The minimum clear height of the equipment and air washer rooms shall be 3.6 m. The actual height required would depend upon the capacity of the equipment and manufacturer's recommendation.

3.7.2 Equipment Location

- i) The plant room shall be located contiguous to the space to be ventilated to reduce the pressure drop in the system.
- ii) Where air washers are also to be installed the room shall be treated with waterproof treatment and shall be located adjacent to the blower room.
- iii) The plant room shall be so located that it is conveniently possible to exhaust or inject the air to / from the ambient.

3.7.3 Floor loading & other Structural Requirements

- i) The floor loading of the plant room and air washer room shall be 2000 kg./sq.m.
- ii) The doors of the plant room and air washer room shall be single leaf, air tight and open able outside. The floor and walls of the air washer room shall be properly treated, preferably with tiles to prevent seepage of water to the adjoining areas. The floor of the air washer room shall be properly sloped towards the drain point.
- iii) The air washer room shall be provided with water and drain points.
- iv) Fresh air opening along with masonry louvers, fresh water connection and drain outlet shall be provided in the plant room / air washer room.

3.8 COLD ROOMS

3.8.1 Space Requirements

- i) The space requirement shall have to be worked out in individual cases depending upon the system selected.
- ii) Sufficient space should be kept around the equipments for operation and maintenance purposes.
- iii) Normal room height in the building should be adequate for the equipment room as well as the cold room.

3.8.2 Equipment Location

- i) **Plant Room**
The plant room shall have to be necessarily adjacent to the cold room where DX system is used. The plant room shall have easy accessibility

for men and materials and shall be well ventilated. In an air-cooled system, the condenser shall have to be located in a well ventilated space and preferably within the equipment room.

- ii) AHU's Rooms and Cooling Towers
These shall be located as under 3.4.2 & 3.5

3.8.3 Floor loading and other Structural Requirements

- i) The floor loading for the equipment room shall be 2000 kg /sq. m.
- ii) The floor loading/ weight of the equipment for AHU rooms and cooling towers shall be as under 3.3.4 & 3.5.
- iii) Where the cold rooms are located in the uppermost floor, the roof slab shall be provided with effective water proofing treatment to avoid any damage to the insulation of the cold room. For the same reason, the cold rooms shall be located away from the wet areas such as toilets.
- iv) Where the cold rooms are located on the ground floor, the flooring shall be effectively treated to prevent any seepage of water from the ground into the cold room.
- v) Suitable insulation along with vapour barrier shall be provided on all the sides of the cold room including the roof and flooring, especially in low humidity applications.

3.9 GENERAL STRUCTURAL REQUIREMENTS

- i) If the building is air conditioned, the roof of the air conditioned areas & W.M. room shall have insulation on the roof (preferably over deck insulation wherever possible) and insulation in the walls. Buildings or complexes that have a connected load of 100kW or greater or an air-conditioned area of 1000 m² or more should comply with the thermal transmittance value (U-factor) requirements or R- value of insulation specified below. The U-factor takes into account all elements or layers in the construction assembly, including the sheathing, interior finishes, and air gaps, as well as exterior and interior air films. The roof insulation shall not be located on a suspended ceiling with removable ceiling panels.

Roof Assembly U-Factor and Insulation R-Value Requirements

Climate zone	24-Hour use buildings- Hospitals, Hotels, etc.		Daytime use buildings Other building Types	
	Maximum U-Factor of the overall Assembly (W/m ² -C)	Minimum R-value of Insulation Alone (m ² .K/W)	Maximum U-Factor of the overall Assembly (W/m ² -C)	Minimum R-value of insulation alone (m ² .K/W)
Composite		R-3.5		R-2.1
Hot and Dry		R-3.5		R-2.1
Warm and Humid		R-3.5		R-2.1
Moderate		R-2.1		R-2.1
Cold		R-3.5		R-2.1

Opaque Wall Assembly U-Factor and Insulation R-Value Requirements

Climate zone	24-Hour use buildings- Hospitals, Hotels, etc.		Daytime use buildings Other building Types	
	Maximum U-Factor of the overall Assembly (W/m ² -C)	Minimum R-value of Insulation alone (m ² .K/W)	Maximum U-Factor of the overall Assembly (W/m ² -C)	Minimum R-value of insulation alone (m ² .K/W)
Composite		R-2.1		R-2.1
Hot and Dry		R-2.1		R-2.1
Warm and Humid		R-2.1		R-2.1
Moderate		R-2.1		R-2.1
Cold		R-2.2		R-2.35

- ii) All the glazed window of air-conditioning areas shall preferably be provided with double pane glass windows.
- iii) Buildings or complexes that have a connected load of 100kW or greater or an air-conditioned area of 1000 m² or more should comply with the fenestration requirements (as applicable) specified below:

Climate zone	Vertical fenestration U-Factor (W/m ² -C) and SHGC requirements		
		WWR ≤ 40%	40% < WWR ≤ 60%
	Maximum U-Factor	Maximum SHGC	Maximum SHGC
Composite	3.3	0.25	0.2
Hot and Dry	3.3	0.25	0.2
Warm and Humid	3.3	0.25	0.2
Moderate	6.9	0.4	0.3
Cold	3.3	0.51	0.51

Minimum VLT Requirements	
Window Wall ratio	Minimum VLT
0-0.3	0.27
0.31-0.4	0.2
0.41-0.5	0.16
0.51 - 0.6	0.13

Climate zone	Skylight U-Factor (W/m ² -C) and SHGC requirements			
	Maximum U-Factor		Maximum SHGC	
	With curb	w/o curb	0-2% SRR	2.1-5% SRR
Composite	11.24	7.71	0.4	0.25
Hot and Dry	11.24	7.71	0.4	0.25
Warm and Humid	11.24	7.71	0.4	0.25
Moderate	11.24	7.71	0.61	0.4
Cold	11.24	7.71	0.61	0.4

- iv) All the doors/ windows of air-conditioned areas shall be made airtight. Air leakage for glazed swinging entrance doors and revolving doors shall not exceed 5.0 l/s m². Air leakage for other fenestration and doors shall not exceed 2.0 l/s m².
- v) The following areas of the enclosed building envelopes shall be sealed, caulked, gasketed, or weather stripped to minimize air leakage:
 - a) Joints around fenestration and door frames
 - b) Openings between walls and foundation and between walls and roof and wall panels.
 - c) Opening at penetrations of utility services through roof, walls, and floors
 - d) Site-built fenestration and doors
 - e) Building assemblies used as ducts and plenums
 - f) All other openings in the building envelope
- vi) For air conditioning areas, where the return air is collected/ carried back to AHU rooms above false ceiling, the false ceiling shall be airtight & preferably shall be of Gypsum Board.
- vii) Total water requirements of air conditioning plant shall be assessed @ 15 litre/TR/Hr of plant operation. For 24 hour operation the number of operating hours shall be taken as 16. For small central plants a makeup water tank of same capacity shall be provided along the cooling towers with bottom of this make up tank being at least 0.75 mtrs above the sump level of cooling tower. For large size central plants an underground tank of total water requirement capacity shall have to be provided near the A.C. Plant room and a makeup water tank of part water requirement shall be provided along with cooling towers.

3.10 CHECK LIST FOR SPACE PROVISIONS FOR CENTRAL AIR CONDITIONING WORKS

- i) A.C Plant room
- ii) AC plant room water connection & drainage
- iii) Cooling tower location
- iv) AHU room
- v) AHU room water connection & drainage
- vi) Shaft for carrying chilled water pipes
- vii) False ceiling co-ordination
- viii) Ceiling height to accommodate ducting
- ix) Water requirement
- x) Routes of piping/ cable
- xi) Thermal/ acoustic insulation
- xii) Air tightness of windows/ doors
- xiii) Insulation for AC areas on top floors.

CHAPTER- 4

PACKAGED TYPE AIR CONDITIONING PLANTS AND VARIBALE REFRIGERANT FLOW/ VOLUME SYSTEM

4.1 WATER COOLED PACKAGED TYPE PLANTS

4.1.1 Scope

This chapter covers the requirements of packaged type air-conditioning plants with water-cooled condensers of 5, 7.5, 10 , 15 and 20 TR capacities.

4.1.2 General Construction :

- i) The packaged type plants shall be self-contained units generally conforming to **IS: 8148 1976 (packaged air- conditioner)**. The plant may have a single or multi refrigeration circuit as per design of respective manufacturers. Each compressor, however, shall have a independent condenser, evaporator & refrigerant circuit.
- ii) The packaged unit shall be constructed with adequate strength and rigidity to withstand handling, transportation and usage.
- iii) The unit shall be fabricated so as to be free from undue noise and vibration. All valves and refrigerant piping shall be suitably clamped.
- iv) The internal components of the unit shall be located so as to be easily accessible for inspection and maintenance. All parts which are accident hazard shall be effectively guarded.
- v) Due care shall be taken in the use of materials likely to come in contact with water, namely, condensate tray, etc. by the use of corrosion resistant material, or by treatment with corrosion resistant coating.
- vi) The unit shall be completely factory assembled.

4.1.3 Cabinet :

- i) The cabinet will have a frame work of either M.S. angles or formed M.S. sheet sections in order to provide structural rigidity. Properly formed close fittings and easily removable sheet metal panels shall be provided all around this frame work to make a closed & streamlined cabinet. The sheet used shall be of minimum 1.25mm thickness.
- ii) Inside and outside surfaces shall be finished with polyester epoxy powder coating.
- iii) The fan section and coil section of cabinet shall be insulated with at least 25mm resin bonded fibre glass lining on the inside duly finished with minimum 0.5mm thick aluminium sheet.
- iv) An insulated condensate tray shall be provided beneath the cooling coil so as to avoid dripping over the equipment installed in the lower portion of the cabinet. The drip tray should have a drain connection for leading away the condensate.

- v) A conditioned air outlet from the cabinet should be provided with suitable flanges in order to connect it to the canvas of the supply air ducting at the cabinet top.
- vi) A return grill of streamlined design shall be provided in the elevation in front of the filter section. This grill should be easily removable for inspection / maintenance of filter.

4.1.4 Compressor :

- i) Compressor shall be scroll hermetic or semi hermetic type suitable for CFC/HCFC free refrigerant.
- ii) It shall be fitted with suction and discharge stop valves, permitting full servicing facilities, built in safety controls, filters, release valves, control valve and other standard accessories.
- iii) The compressor shall be installed on vibration isolating resilient material, so as to ensure operation with the minimum noise and vibrations.
- iv) Each compressor shall be provided with protection against high refrigerant pressure and low refrigerant pressure, anti-cycle timer, indication lamps, fault alarm etc through microprocessor controller.
- v) Compressor shall be designed for 4.4 deg C suction temperature and 43.3 deg C discharge temperature.

4.1.5 Compressor Drive :

- i) The compressor motor shall be squirrel cage induction motor capable of continuous operation at 415 V \pm 10% , 50 Hz, 3 phase AC supply.
- ii) The motor shall be suction cooled, in case of sealed semi-hermetic type units.
- iii) The starter shall be as per para 13.9 and shall be provided on the packaged unit itself.

4.1.6 Condenser :

- i) Condenser shall be of horizontal shell and tube construction with M.S. shell and integrally finned copper tubes. Thickness of tube shall be minimum 1.0 mm before finning.
- ii) The end covers shall be removable type and suitable provision shall be made in the unit cabinet, enabling easy cleaning of condenser tubes.
- iii) The condenser shall serve as liquid receiver for the refrigerant circuit & shall be complete with following: -
 - a) Inlet and outlet refrigerant connections.
 - b) Inlet and outlet water connections.
 - c) Relief / purge valve and connections.

- d) Drain valve, air vent, test cock connection, facility with valves for descaling of tubes etc.

4.1.7 Cooling Coil

- i) Cooling coil shall be 3 or 4 rows deep, as per manufacturer's standards, made of copper tubes of minimum 0.5 mm thickness and aluminium fins of minimum 0.15 mm thickness, mechanically bonded to the coils.
- ii) No of fins per cm of tube shall be 4 to 5.
- iii) Coil shall be fitted with equalizing copper distributor to ensure that each coil circuit receives equal amount of refrigerant.
- iv) The coil shall be designed for a face velocity of not more than 155 m/min. Coil shall be thoroughly evacuated, dried and pressure tested to 21 Kg /sq.cm (300 psi).

4.1.8 Refrigerant Plumbing

- i) The unit shall be complete with refrigerant plumbing using copper tubes. Plumbing work shall be in accordance with para 5.7 of these specifications.
- ii) The refrigerant circuit shall include thermo-static expansion valve and suction gas stainer.
- iii) The work shall include provision of suction line insulation as per manufacturer standards.

4.1.9 Fan and Drive

- i) Fan shall be statically and dynamically balanced single/double inlet centrifugal type, designed for quiet operation. The fan wheel shall be constructed of aluminium or galvanised steel. Self-oiling bearing easily accessible for maintenance, with thrust collar shall be provided. Preferably, the bearings shall be life lubricated sealed type, mounted on vibration absorbing resilient supports.
- ii) The fan shall be belt driven through adjustable pulley permitting air quantity to be varied by adjusting the fan speed. Suitable fan belt tension adjusting arrangement shall be provided.
- iii) The fan motor shall be mounted within the cabinet. This shall be of TEFC enclosure, squirrel cage, induction motor of suitable HP for the duty involved. This shall be located with proper alignment with fan pulley for the belt drive.
- iv) Starter (DOL) and independent SPP shall be provided.
- v) The CMH and static pressure of the fan shall be as specified in the schedule of work.

4.1.10 Interlocking

The compressor motor shall be interlocked with the following:

- i) Air flow switch in the evaporator fan discharge
- ii) Differential pressure switch in the condenser water line
- iii) Condenser water pump
- iv) Cooling tower fan motor

4.1.11 Filters

- i) Cleanable aluminium wire mesh/ synthetic media type air filters, at least 25 mm thick, shall be provided, swung fit to prevent air by pass.
- ii) Face velocity across the filters shall not exceed 100 m/min.

4.1.12 Humidification

Where close control of RH is required provision of pan type humidifier shall be made as per para 6.2.3.6.2.

4.1.13 Micro process controller

Each packaged units shall be equipped with a micro-processor controller having all operating & safety controls.

4.1.14 Insulation

Insulation of packaged units shall be as per para 4.1.3 (iii) & Chapter 11 of these specification.

4.1.15 Power Consumption Rating for Packaged Air Conditioner under test conditions

Cooling Capacity		Maximum Power Consumption in Watts	
Watts	Tons of Refrigeration	Water Cooled	Air Cooled
10,000	3	3,750	4,750
17,500	5	6,000	7,000
26,250	7.5	9,000	10,000
35,000	10	11,500	13,500
52,000	15	17,000	20,000

4.2 AIRCOOLED PACKAGED TYPE PLANTS

4.2.1 Scope

This chapter covers the requirements of packaged type air-conditioning plants with air-cooled condensers of 5, 7.5, 10 , 15 and 20 TR capacities.

4.2.2 General Construction

- i) The air-cooled package unit shall be supplied in two portions –outdoor portion made up of the condenser & condenser fan and indoor unit

made up of the evaporator & evaporator fan. The compressor can be provided along with the condenser or the evaporator depending upon the manufacturer's practice or the required application at site.

- ii) The two portions shall be piped together at site.
- iii) General construction shall be as per 4.1.2.

4.2.3 Cabinet

The cabinet shall be provided separately for the two portions as shown per para 4.1.3.

4.2.4 Compressor and Compressor Drive

These shall be as per 4.1.4 and 4.1.5

4.2.5 Condenser

The condenser shall be air-cooled and shall be in general conforming to para 5.5.4

4.2.6 Cooling Coil

This shall be as per 4.1.7

4.2.7 Refrigerant Piping

This shall be as per 4.1.8.

4.2.8 Fan and Drive

- i) These shall be as per 4.1.9.
- ii) Separate fans along with their drives shall be provided for the condenser and evaporator portions.

4.2.9 The compressor motor shall be interlocked with the following:

- i) Air flow switch in the evaporator fan discharge.
- ii) Air flow switch in the condenser fan discharge.

4.2.10 Filters

These shall be as per 4.1.11

4.2.11 Humidification

Where specified, this shall be provided as per 4.1.12

4.2.12 Insulation

Insulation of packaged units shall be as per para 4.1.3 (iii) & Chapter 11 of these specification.

4.3 VARIBALE REFRIGERANT VOLUME/ FLOW SYSTEM

The system selected is a modular system, with number of indoors connected to centrally located outdoor units. The outdoor units for all the system shall be air cooled type.

4.3.1 General Description

All the VRF air conditioners shall be fully factory assembled, wired, internally piped & tested. The outdoor unit shall be pre-charged with first charge of refrigerant. Additional charge shall be added as per refrigerant piping at site. All the units shall be suitable for operation with 415 V \pm 10%, 50 Hz \pm 3%, 3 Phase supply for outdoor units; & 220 V \pm 10%, 50 Hz \pm 3%, 1 Phase supply for indoor units.

4.3.2 Specifications of Outdoor units :

- i) Outdoors units of the VRV system shall be compact air cooled type.
- ii) The outdoor unit should comprise of Inverter controlled Twin Rotary Compressor / Scroll Compressor
- iii) Each module of outdoor unit must have at least 50 % of Variable compressor which can work on Part load Suitable to operate at heat load proportional to indoor requirement.
- iv) The ODU must deliver COP of minimum 4.7 at 50 % load.
- v) The outdoor units must be suitable for up to 225 m refrigerant piping between outdoor unit & the farthest indoor units. Allowable level difference between outdoor unit & indoor units shall be 50 m in case of outdoor unit on top & 40 m in case of outdoor unit at bottom.
- vi) Allowable level difference between various indoor units connected to one out door unit shall be up to 15 m.
- vii) The outdoor units shall be suitable to operate within an ambient temperature range of 5 Deg C to 43 Deg C in cooling mode; & -20 Deg C to 15 Deg C in heating mode.
- viii) The entire operation of outdoor units shall be through independent remotes of indoor units. No separate Start/ Stop function shall be required.
- ix) Starter for the Outdoor Unit compressor shall be "Direct on Line" type. Inverter compressor of the unit shall start first & at the minimum frequency, to reduce the inrush current during starting.
- x) Complete refrigerant circuit, oil balancing/ equalizing circuit shall be factory assembled & tested

4.3.3 Specifications of Indoor units :

The units include pre-filter, fan section and DX coil section. The housing of units shall be light weight powder coated galvanized steel. Units shall have external casing of ABS Plastic for supply and return air.

- i) 4 Way Cassette type indoor units :
 - (a) These units shall be installed between the bottom of finished slab & top of false ceiling.
 - (b) Unit shall have provision of connecting fresh air without any special chamber & without increasing the total height of the unit (320 mm maximum).

- (c) The unit must have in built drain pump, suitable for vertical lift of 750 mm.
- (d) Unit must be insulated with sound absorbing thermal insulation material, Polyurethane foam. The sound pressure level of unit at the highest operating level shall not exceed 46 dB (A).
- (e) The unit must have drain pump kit if. The drain pump must be suitable to lift drain up to 1000 mm from the bottom of the unit.

ii) 4 Way Compact Cassette type indoor units.

- (a) The compact cassette unit should perfectly fit into ceilings and match the standard architectural modules, without the need to cut ceiling tiles.
- (b) The flaps fold tightly against the ceiling when operation stops so that the ceiling is affected only slightly even if air conditioning is installed.
- (c) Designed for simple & easy installation and maintenance. It should be slim in design only 268 mm in height even when an electrical box is located inside the unit.
- (d) The unit must have drain pump kit if. The drain pump must be suitable to lift drain up to 1000 mm from the bottom of the unit.

iii) Concealed duct type units

- (a) These units shall be ceiling suspended with suitable supports to take care of operating weight of the unit, without causing any excessive vibration & noise.
- (b) The cold air supplied by these units will be supplied to the area to be air conditioned, through duct system specified in the tender.
- (c) Each indoor unit must have electronic expansion valve operated by microprocessor thermostat based temperature control to deliver cooling/ heating as per the heat load of the room
- (d) The Sound Pressure level of unit at the highest operating level shall not exceed 38 dB (A), at a vertical distance of 1.5 m below the units with duct connected to the unit.
- (e) The unit must have provision of adding drain pump kit if required & specified. The drain pump must be suitable to lift drain up to 1000 mm from the bottom of the unit.

iv) Wall Mounted Units.

- (a) Wall mounted units must be compact & stylish design that does not detract from the décor of the room.
- (b) Each indoor unit must have electronic expansion valve operated by microprocessor thermostat based temperature control to deliver cooling/ heating as per the heat load of the room.
- (c) The unit must have provision of adding drain pump kit if required & specified. The drain pump must be suitable to lift drain up to 1000 mm from the bottom of the unit.
- (d) The sound pressure level of unit at the highest operating level shall not exceed 46 dB(A).

(e) Refrigerant control in the indoor unit shall be through Electronic Expansion Valve.

v) Installation:

- (a) The units shall be mounted on ribbed rubber pads for vibration isolation. The contractor shall supply the required charge of refrigerant, lubricant and other consumables, for commissioning and testing of the equipment.
- (b) All the equipment shall be thoroughly tested and checked for leaks. All safety controls shall be suitably set and a record of all setting shall be furnished to the project supervisor.
- (c) Providing and fixing M.S. structural support for condensing unit with vibration isolator pad in-between support and structure and vibration isolation suspender and pads for evaporating units shall be in scope of contractor.

vi) Painting:

Shop coats of paint that have become marred during transportation or erection shall be cleaned off with mineral spirits, wire brushed and spot primed over the affected areas, then coated with enamel paint to match the finish over the adjoining shop- painted surfaces.

vii) Condensate Drain Piping:

All pipes to be used for condensate drain shall be PVC pipe conforming to IS: 4985 - Class I & all joints should be Gluing or solvent cementing as per manufacturer recommendation.

viii) Refrigerant Piping:

- (a) All refrigerant pipes and fittings shall be type 'L' hard drawn copper tubes and wrought copper fitting suitable for connection with silver solder. The copper thickness of wall shall be 20G/ 22G(0.7 to 1 mm)
- (b) All joints in copper piping shall be swaged joints using low temperature brazing and/ or silver solder. Before jointing any copper pipe or fittings, its interior shall be thoroughly cleaned by passing a clean cloth via wire or cable through its entire length. The piping shall be continuously kept clean of dirt etc. while construction of the joints. Subsequently, it shall be thoroughly blown out using nitrogen.
- (c) Refrigerant lines shall be sized to limit pressure drop between evaporator and condensing unit to less than 0.2 kg per Sq.cm.
- (d) After the refrigerant piping installation has been completed the refrigerant piping system shall be pressure tested using, Freon mixed with nitrogen at a pressure of 20 Kg per Sq. cm. (High side) and 10 Kg per Sq. cm (Low side). Pressure shall be maintained on the system for 24 hours.
- (e) The system shall then be evacuated to a minimum vacuum of 70 cm. of mercury and held for 24 hours, during which time; change in

vacuum shall not exceed 12 cm of mercury.

- (f) All refrigerant piping shall be installed strictly as per the instructions and recommendations of air conditioning equipment manufacturers.

ix) Power Supply:

- (a) Power supply near the indoor unit will be provided by the department with suitable 6A plug point socket & switch.
- (b) However, where the power requirement is of central control from ODUs, as per the design of the system, the entire power supply then shall be done by the contractor.

CHAPTER –5

CENTRAL AIR CONDITIONING PLANT

5.1 SCOPE

This chapter describes central Air-conditioning plant with factory assembled & tested chilling units comprising of reciprocating/ **scroll**/ centrifugal/ screw compressor, as the case may be, direct driven with electric motor, water/ air-cooled condenser, chiller, connecting refrigerant plumbing, microprocessor based safeties and controls including first charge of refrigerant & compressor oil.

5.2. RECIPROCATING COMPRESSORS

5.2.1 Type

Reciprocating compressor shall be multi cylinder open type, semi-sealed (semi-hermetic), or totally (hermetically) sealed type. It shall be using CFC/ HCFC free refrigerant only. The suction chamber of the compressor should be of generous proportions and should have changes of direction of flow to ensure separation of entrained oil and liquid refrigerant from the gas before it enters suction manifold.

5.2.2 Drive

The compressor shall be direct driven.

5.2.3 Crankcase heaters.

- i) The compressors shall be equipped with electrical crankcase heaters. These heaters shall be fitted in steel pockets to avoid the oil coming in direct contact with the heating element. The heater elements shall remain energized only during the off cycle of the compressor and shall be de-energized when the compressor is operating to prevent the mixing of oil and refrigerant and their accumulation in the crankcase when the compressor is off.
- ii) An indicating light and a push button switch shall be provided for testing the continuity of the heater element.

5.2.4 Lubrication system

- i) The lubrication system shall be force feed type with a reversible positive displacement type oil pump to provide pressure lubrication to bearings and other wearing surfaces.
- ii) The crankcase shall be fitted with the following: -
 - a) A pump suction strainer,
 - b) An oil level bull's eye to check the oil level,
 - c) An oil drain with a magnetic drain plug,

- d) Connection for oil pressure gauge with control valve

5.2.5 Isolating valves and accessories

- i) Suction and discharge isolating valves shall be provided for each compressor.
- ii) The compressor shall be complete with all accessories such as pipe flanges, suction strainers, etc.

5.2.6 Safety Controls

Safety controls shall be provided as per details given under para 12.2 "Equipment Safety controls."

5.2.7 Capacity controls

Each compressor shall be equipped for capacity control by cylinder unloading. Unloading shall be achieved by lifting of suction valves or through bypass valves in the discharge chamber. The capacity control mechanism shall be so arranged that the compressor starts unloaded and shall be loaded in stages up to 100% loading of the compressor.

5.2.8 Interlocking

The compressor motor shall be interlocked with the following: -

- i) Differential pressure switch in the chilled water line(s) in case of chilled water system, and air flow switch in the evaporator fan discharge in the case of direct expansion system.
- ii) Differential pressure switch in the condenser water line(s) in case of water cooled condenser and air flow switch in the condenser fan discharge in the case of air cooled condenser.
- iii) Anti-freeze thermostat in case of chiller.
- iv) Condenser water pump in case of water cooled condenser and condenser fan in case of air cooled condenser.
- v) Chilled water pump in case of chilled water system and evaporator fan in case of direct expansion system.

The interlocks shall be provided with indicating lamps or flags in the control panel in the refrigeration plant room.

5.2.9 Drive Motor

- i) The electrical motor driving the compressor shall be squirrel cage induction motor class 'F' insulation, fan cooled for open type unit; and totally enclosed, (refrigerant cooled) for hermetic/ semi-hermetic unit. The motor shall be suitable for operation on $415 \pm 10\%$ volts, 3 phase,

50 HZ alternating current supply, unless otherwise specified. The motor synchronous speed shall not exceed 1500 r.p.m.

- ii) For open type compressor, the continuous B.H.P. rating of the motor shall be at least 110% of the maximum power requirement of compressor and drive under specified design conditions.

5.2.10 Motor Starter

These shall be same as per details given under para 13.9 "Motor Starter".

IKW / TR (Input Kilo Watt / TR) shall not exceed 0.84 at ARI condition or COP at ARI condition shall not be lower than 4.2.

5.3 **SCROLL COMPRESSORS:**

- A) Compressors: Shall be hermetic, scroll-type, including:
 - i) Compliant design for axial and radial sealing.
 - ii) Refrigerant flow through the compressor with 100% suction cooled motor.
 - iii) Large suction side free volume and oil sump to provide liquid handling capability.
 - iv) Compressor crankcase heaters to provide extra liquid migration protection.
 - v) Annular discharge check valve and reverse vent assembly to provide low-pressure drop, silent shutdown and reverse rotation protection.
 - vi) Initial oil charge.
 - vii) Oil level sight glass.
 - viii) Vibration isolator mounts for compressors.
 - ix) Brazed-type/ shell and tube connections for fully hermetic refrigerant circuits.
 - x) Compressor Motor overloads capable of monitoring compressor motor current. Provides extra protection against compressor reverse rotation, phase-loss and phase-imbalance.

Chiller power consumption values shall be as per ECBC norms.

5.4 **CENTRIFUGAL COMPRESSORS (CONSTANT SPEED AND VARIABLE SPEED)**

- 5.4.1 Type- Centrifugal compressor shall be open/ semi-sealed/ totally sealed type. It shall be working on **CFC and HCFC free refrigerant**. The impeller shall be of shrouded design and made of cast aluminium alloy of high strength and protected against corrosion. This shall be statically and dynamically balanced and over speed tested so as to ensure vibration free operation. The impeller shaft or drive end of the gear shaft, as the case may be, shall be connected with the motor through a flexible coupling in case of open design and rotor shaft in case of hermetic design. The compressor casing shall be of high strength ductile casting and of such design that servicing can be carried out without disturbing connections.

5.4.2 Drive gear

- i) The centrifugal compressor **shall be preferably variable speed.**
- ii) The variable speed compressor shall have compressor/ chiller manufacturer's factory matched variable speed drive.
- iii) Where the impeller is designed for operation at speed higher than the drive motor, necessary speed increasing gear shall be connected to the impeller shaft in a self aligning and balanced way. The gears and pinion shall be pressure lubricated.
- iv) Variable speed drive (VSD) drive shall be installed with appropriate controls in accordance with section 5.3.11 and 5.3.12

5.4.3 Bearings :

The compressor shall incorporate the necessary design features to take both axial and radial thrusts. The bearings shall be of self aligning type. The bearing shall be pressure lubricated during operation and shall be completely sequenced and interlocked with the start up of the machine in such a way that oil pump should start earlier than the machine and the machine should start after some time, provided the required oil temperature and pressure is maintained during the start up period.

5.4.4 Shaft seal :

The compressor shaft seal (in case of open type machines) shall be as per manufacturer's standard design.

The seal should have small face area and low rubbing speed. It should provide an efficient seal under both vacuum and pressure lubricated during compressor operation. The seal must effectively prevent the leakage of refrigerant along the shaft during shut down periods. During operation an oil film should prevent outward leakage of refrigerant.

5.4.5 Lubrication system :

Lubrication system must ensure complete forced and speed lubrication (at a pressure and controlled temperature) to all bearing surfaces under any speed conditions, at start up, at shut down and during operation at various loads. Adequate arrangement shall be provided to take care of lubrication during failure of power or abnormal shutdown. Full lubrication must be available to the machine during acceleration and deceleration periods through an automatic auxiliary motor driven pump. The lubrication system should include the following:

- a) **Filter mesh size shall be as per manufacturer's standard.**
- b) Oil level indicator
- c) Oil coolers and oil heaters (with built-in thermostat to aid maintaining constant temperature)

5.4.6 The compressor shall be complete with all accessories such as drive arrangement (for open drive machines), capacity control, safety controls.

5.4.7 Capacity Control :

- a) The compressor shall be equipped for modulating the capacity from 100% upto the 25% **at constant condenser entering water temperature without surging and hot gas bypass**. The pre rotation vanes located at the impeller inlet for controlling the capacity shall be aerofoil shaped and shall be made as per manufacturer's standard. The vane position shall be controlled through hydraulic/ linkage system.
- b) The positioning of the vane shall be through microprocessor-based controller with its sensing elements in the outgoing chilled water lines. The automatic damper will enable maintenance of specified chilled water temperature within ± 0.11 deg C.

5.4.8 Safety Control :

Safety controls shall be provided as per details given under para 12.2 "Equipment Safety controls."

5.4.9 Inter locking

It shall be as per details given in para 5.2.8.

5.4.10 Drive motor:

- i) The drive motor shall be an independent and coupler type or semi-hermetic/ hermetic type depending on the design adopted by the manufacturer.
- ii) The electric motor shall be of squirrel cage type and shall be suitable for operation on 400/415 V $\pm 10\%$, 3 phase, 50 Hz, AC supply. **All Compressor motors in Screw and Centrifugal chillers with variable speed compressors shall be provided with VFD and shall also be suitably designed for use with Variable Frequency Drive.**
- iii) Synchronous speed of the motor shall not exceed 3000 RPM.
- iv) Continuous BHP rating of the motor shall not be less than the maximum power requirement of the compressor and drive under specified design conditions.
- v) The motor shall be TEFC or SPDP as per installation requirement for open type chiller unit and Totally Enclosed refrigerant cooled for hermetic / semi hermetic type chiller unit. **For outdoor (exposed to atmosphere) chiller applications , TEFC motor shall be used .**
- vi) Motor protection during over current shall be provided through winding temperature sensor in case of refrigerant cooled motors/ current sensing in each phase through microprocessor in case of open type air cooled motors.
- vii) Power factor correction capacitors as required to maintain a displacement power factor of 95% at all load conditions shall be provided.

5.4.11 Control Console :

The chiller shall be controlled by a stand-alone microprocessor based control center. The chiller control panel shall provide control of chiller operation and monitoring of chiller sensors, actuators, relays and switches.

The chiller control panel shall also provide:

1. System operating information including:
 - i) return and leaving chilled water temperature
 - ii) return and leaving condenser water temperature
 - iii) evaporator and condenser saturation temperature
 - iv) differential oil pressure
 - v) percent motor current
 - vi) evaporator and condenser saturation temperature
 - vii) compressor discharge temperature
 - viii) oil reservoir temperature
 - ix) compressor thrust bearing positioning and oil temperature
 - x) operating hours
 - xi) number of compressor starts

2. Digital programming of setpoints through the universal keypad including:
 - i) leaving chilled water temperature
 - ii) percent current limit
 - iii) pull-down demand limiting
 - iv) six-week schedule for starting and stopping the chiller, pumps and tower
 - v) remote reset temperature range

3. Status messages indicating:
 - i) system ready to start
 - ii) system running
 - iii) system coast down
 - iv) system safety shutdown-manual restart
 - v) system cycling shutdown-auto restart
 - vi) system pre-lube
 - vii) start inhibit

4. The text displayed within the system status and system details field shall be displayed as a color coded message to indicate severity: red for safety fault, orange for cycling faults, yellow for warnings, and green for normal messages.

5. Safety shutdowns enunciated through the display and the status bar, and consist of system status, system details, day, time, cause of shutdown, and type of restart required. Safety shutdowns with a fixed speed drive shall include:
 - i) evaporator – low pressure
 - ii) evaporator – transducer or leaving liquid probe
 - iii) evaporator – transducer or temperature sensor
 - iv) condenser – high pressure contacts open

- v) condenser – high pressure
- vi) condenser – pressure transducer out of range
- vii) auxiliary safety – contacts closed
- viii) discharge – high temperature
- ix) discharge – low temperature
- x) oil – high temperature
- xi) oil – low differential pressure
- xii) oil – high differential pressure
- xiii) oil – sump pressure transducer out of range
- xiv) oil – differential pressure calibration
- xv) oil – variable speed pump – pressure setpoint not achieved
- xvi) control panel – power failure
- xvii) motor or starter – current imbalance
- xviii) thrust bearing – proximity probe clearance
- xix) thrust bearing - proximity probe out – of – range
- xx) thrust bearing – high oil temperature
- xxi) thrust bearing – oil temperature sensor
- xxii) watchdog – software reboot

5.1 Safety shutdowns with a VSD Shall include:

- i) VSD shutdown – requesting fault data
- ii) VSD – stop contacts open
- iii) VSD – 110 % motor current overload
- iv) VSD – high phase A, B,C inverter heat-sink temp.
- v) VSD – high converter heat-sink temperature

6. Cycling shutdowns enunciated through the display and the status bar, and consists of system status, system details, day, time, cause of shutdown, and type of restart required. Cycling shutdowns with a fixed speed drive shall include:

- i) multiunit cycling – contacts open
- ii) system cycling - contacts open
- iii) oil – low temperature differential
- iv) oil – low temperature
- v) control panel - power failure
- vi) leaving chilled liquid - low temperature
- vii) leaving chilled liquid - flow switch open
- viii) motor controller – contacts open
- ix) motor controller – loss of current
- x) power fault
- xi) control panel - schedule
- xii) starter – low supply line voltage
- xiii) starter – high supply line voltage
- xiv) proximity probe – low supply voltage
- xv) oil - variable speed pump - drive contacts open

6.1 Cycling shutdowns with a VSD shall include:

- i) VSD shutdown – requesting fault data
- ii) VSD – stop contacts open
- iii) VSD initialization failed
- iv) VSD - high phase A,B,C instantaneous current
- v) VSD – phase A,B,C gate driver
- vi) VSD – single phase input power
- vii) VSD – high DC bus voltage
- viii) VSD – pre charge DC bus voltage imbalance
- ix) VSD – high internal ambient temperature
- x) VSD – invalid current scale selection
- xi) VSD – low phase A, B, C inverter heatsink temp.
- xii) VSD – low converter heatsink temperature
- xiii) VSD – pre-charge - low DC bus voltage
- xiv) VSD – logic board processor
- xv) VSD – run signal
- xvi) VSD – serial communications

5.4.12 Motor starter

- i) For constant speed compressor
Starter for motor shall be as per details given under para 13.9 “Motor Starter”.
- ii) For variable speed compressor
 - a) In Case of VSD starter, it will vary the compressor motor speed by controlling the frequency and voltage of the electrical power to the motor. The adaptive capacity control logic shall automatically adjust motor speed and compressor pre-rotation vane position independently for maximum part-load efficiency by analyzing information fed to it by sensors located throughout the chiller.
 - b) To Limit Harmonic generation from VSD, Active Harmonic Filters as per IEEE 519 must be used at the source itself.
 - c) Drive will be PWM type utilizing IGBT’s with a power factor of 0.95 or better at all loads and speeds.
 - d) Make of VSD shall be exactly same as per global catalogue / practice. The variable speed drive shall be with all power and control wiring between the drive and chiller factory installed, including power to the chiller oil pump.
 - e) Field power wiring shall be a single point connection and electrical lugs for incoming power wiring will be provided.
- iii) The following features will be provided:
 - (a) Door interlocked circuit breaker capable of being padlocked.
 - (b) UL listed ground fault protection.
 - (c) Over voltage and under voltage protection.
 - (d) 3-phase sensing motor over current protection.

- (e) Single phase protection.
- (f) Insensitive to phase rotation.
- (g) Over temperature protection.

Digital readout at the chiller unit control panel of output frequency, output voltage, 3-phase output current, input Kilowatts and Kilowatt-hours, self-diagnostic service parameters. Separate meters for this information will not be acceptable.

5.4.13

IKW / TR :

For constant speed compressor

For capacity < 150 TR, IKW/TR shall not exceed 0.61

For capacity >150 TR and <300 TR, IKW/TR shall not exceed 0.61

For capacity > 300 TR, IKW/TR shall not exceed 0.56

For variable speed compressor

IPLV of the compressor shall not exceed 0.35.

5.5 SCREW TYPE COMPRESSOR (CONSTANT SPEED AND VARIABLE SPEED)

5.5.1 The screw compressor shall have a rotary mono/ twin screw, and may be of open/ Semi-sealed / totally (hermetic) sealed type. It shall be using only CFC and HCFC free refrigerant.

5.5.2 **The screw compressor shall be preferably variable speed.** The variable speed compressor shall have factory mounted variable speed drive.

5.5.3 The mono/ twin rotary screw shall be manufactured from forged steel. The profile of screws shall permit safe operation upto a speed of 3000 RPM for 50 Hz operation. The compressor shall unload from fully loaded to the minimum capacity by means of hydraulically actuated slide valve positioned over the screw rotor/ pilot operated solenoid valve **& VFD (in case of VFD chillers).**

5.5.4 The compressor housing shall be of high grade cast iron, machined with precision, to provide a very close tolerance between the rotor(s) and the housing.

5.5.5 The rotor(s) shall be mounted on antifriction bearings designed to reduce friction and power input. There shall be multiple cylindrical bearings to handle the radial and axial loads.

5.5.6 There shall be built in oil reservoir to ensure full supply of lubricants to all bearings and a check valve to prevent backspin during shut down.

5.5.7 There shall be oil pump or other means of differential pressure inside the compressor for forced lubrication of all parts during startup, running and during shut down. An oil sump heater shall be provided in the casing.

5.5.8 The open type compressor shall also have a suitable shaft seal, to prevent leakage of refrigerant.

5.5.9 The units shall be complete with automatic capacity control mechanism, to permit modulation between 25% to 100% of capacity range.

5.5.10 Interlocking

It shall be as per details given in para 5.2.8.

5.5.11 The driving motor shall be double squirrel cage type or suitable hermetic/ Semi hermetic/ open type as required, protected against damage by means of built in protection devices.

5.5.12 Compressor motor and starters

- i) These shall be as per details given under para 5.2.9, its synchronous speed, however, shall be 3000 RPM. **All compressor motors in screw chillers shall be provided with VFD wherever feasible.**
- ii) Continuous BHP rating shall be as per para 5.3.10
- iii) Motor Starters: Motor starters shall be zero electrical inrush current (Variable Frequency Drives) or reduced inrush type (Closed transition Star-Delta or Solid State) for minimum electrical inrush. Open transition Star-Delta and Across the Line type starters will not be acceptable.
- iv) Power factor correction capacitors as required to maintain a displacement power factor of 95% at all load conditions shall be provided.

5.5.13 IKW / TR (Input Kilo Watt / TR)

For constant speed compressor,

- i) For chiller capacity < 150 TR, IKW/TR shall not exceed 0.75
- ii) For chiller capacity >150 TR and <300 TR, IKW/TR shall not exceed 0.65
- iii) For chiller capacity > 300 TR, IKW/TR shall not exceed 0.61

For variable speed compressor,
IPLV shall not exceed 0.40.

5.5.14 Controls

5.5.14.1 General:

- i. Provide automatic control of chiller operation including compressor start/ stop and load/ unload, anti-recycle timer, evaporator pump, condenser pump, evaporator heater, condenser heater, unit alarm contacts and run signal contacts.
- ii. Chiller shall automatically reset to normal chiller operation after power failure.
- iii. Unit operating software shall be stored in non-volatile memory. Field programmed set points shall be retained in lithium battery backed regulated time clock (RTC) memory for minimum 5 years.
- iv. Alarm controls shall be provided to remote alert for any unit or system safety fault.

5.5.14.2 Display and Keypad:

- i. Provide minimum 80 character liquid crystal display that is both viewable in direct sunlight and has LED backlighting for nighttime viewing. Provide one keypad and display panel per chiller.
- ii. Display and keypad shall be accessible without opening main control/electrical cabinet doors.
- iii. Display shall provide a minimum of unit setpoints, status, electrical data, temperature data, pressures, safety lockouts and diagnostics without the use of a coded display.
- iv. Descriptions in English (or available language options), numeric data in English (or Metric) units.
- v. Sealed keypad shall include unit On/ Off switch.
- vi. Programmable Setpoints (within Manufacturer limits): Display language, chilled liquid cooling mode, local/ remote control mode, display units mode, system lead/lag control mode, remote temperature reset, remote current limit, remote heat recovery kit, leaving chilled liquid setpoint and range, maximum remote temperature reset.

5.5.14.3 Display Data:

Chilled liquid leaving and entering temperatures; lead system; flow switch status; evaporator/condenser pump status; active remote control; evaporator pressure, discharge, and oil pressures, condenser and economizer pressures per refrigerant circuit; economizer temperature and superheat; sub cooler liquid temperature and superheat; compressor discharge temperature and superheat, motor; temperatures, educator temperature, per refrigerant circuit; compressor speed, condenser level, condenser level control valve; economizer superheat; economizer feed valve percentage open, evaporator/condenser heater status; oil pump status; compressor number of starts; run time; operating hours; evaporator and condenser heater status; history data for last ten shutdown faults; history data for last 20 normal (non-fault) shutdowns.

5.5.14.4 Predictive Control Points:

Unit controls shall avoid safety shutdown when operating outside design conditions by optimizing the chiller controls and cooling load output to stay online and avoid safety limits being reached. The system shall monitor the following parameters and maintain the maximum cooling output possible without shutdown of the equipment: motor current, evaporator pressure, condenser pressure, discharge pressure, starter internal ambient temperature, and starter baseplate temperature.

5.5.14.5 System Safeties:

Shall cause individual compressor systems to perform auto-reset shut down if: high discharge pressure or temperature, low evaporator pressure, low motor current, high/low differential oil pressure, low oil level, low discharge and economizer superheat, smart freeze point protection, high motor temperature, system control voltage, educator clog.

5.5.14.6 Unit Safeties:

Shall be automatic reset and cause compressors to shut down if: low leaving chilled liquid temperature, under voltage, flow switch operation. Contractor shall provide flow switch and wiring per chiller manufacturer requirements.

- 5.5.14.7 Manufacturer shall provide any controls not listed above, necessary for automatic chiller operation. Mechanical Contractor shall provide field

control wiring necessary to interface sensors to the chiller control system.

5.6 MAGNETIC BEARING VARIABLE SPEED CENTRIFUGAL WATER CHILLERS

5.6.1 General Description

- i. Packaged centrifugal chiller including the following: evaporator, motor and compressor, capacity control device, condenser with integral sub cooler, refrigerant metering device, lubrication system, motor starter, control panel with user interface, and – if required – a refrigerant purge system.
- ii. Chiller shall be utilizing an CFC and HCFC free refrigerant that has an Ozone Depletion Potential (ODP) of ZERO, and that has no refrigerant production phase-out date and no phase out date for equipment that uses that refrigerant.
- iii. Refrigerant isolation valves: two butterfly valves, one on the compressor discharge line and one on the liquid line.

5.6.2 Refrigerant flow control

- i. Variable orifice
- ii. Refrigerant level sensing: Monitor refrigerant level in the condenser; report refrigerant level back to unit control panel and control chiller accordingly.
- iii. Refrigerant level control: Adjust valve position via control panel to optimize refrigerant level.

5.6.3 Compressor

- i. Single stage or multi stage
- ii. Fully accessible housing with vertical circular joints.
- iii. Direct driven
- iv. Magnetic bearings
 - a) Levitated shaft position shall be actively controlled and monitored by an X-, Y-, and Z-axis digital position sensor.
 - b) The compressor shall be capable of coming to a controlled, safe stop in the event of a power failure by diverting stored power from the DC bus to the magnetic bearing control system.
- v. Pre-rotation guide vanes positioned by solid rod linkage and connected to an easily serviceable, externally mounted electric actuator.
- vi. Mechanical linkage system that continuously monitors compressor-discharge gas characteristics and optimizes diffuser spacing to minimize impeller gas-flow disruptions.
- vii. The driveline (compressor and motor) and chiller starter shall be individual unit assemblies allowing for independent inspection, service, and repair/replacement. If an integrated driveline and starter package is utilized which is not fully field repairable, the supplier must provide one spare package with the unit.

- viii. The chiller shall utilize a single compressor that delivers the specified performance at all load and lift conditions.

5.6.4 Motor

- i. Semi-hermetic permanent magnet motor.
- ii. Electrical connection: Steel terminal box with gasketed front access cover; overload and overcurrent transformers.

5.6.5 Control panel

- i. Type: Microprocessor based, stand alone/unit mounted.
- ii. Scope: Chiller operation, monitoring of chiller sensors, actuators, relays and switches, and display of all operating parameters.
- iii. Capability: Stable chiller operation at 4°C leaving chilled water temperature without warnings or shutdowns; no freezing or slushing of chilled water.
- iv. Enclosure: Lockable, NEMA 1
- v. Information Display: 10.4" (minimum) color liquid crystal display (LCD) mounted on control panel enclosure door.
- vi. User interface: Operating parameters displayed in a user-friendly, color and graphical format.
- vii. Keypad: Universal type with soft-keys
- viii. Height: Eye level and readable and operable without the need for ladder or stool.
- ix. Temperature rating: 0 to 40 °C
- x. System status information: Displayed on screen at all times, including the following as a minimum:
 - a) System status
 - b) System details
 - c) Control source (remote or local)
 - d) User access level
 - e) Date and time
 - f) Startup sequence timer
 - g) Shutdown sequence timer
- xi. Status messages: In color according to importance, indicate the following as a minimum:
 - a) Ready to start
 - b) Cycling shutdown – chiller will automatically restart
 - c) Safety shutdown – chiller requires manual restart
 - d) Soft shutdown – chiller requires manual restart
 - e) Motor bearing controller (MBC) start-up
 - f) System run (with countdown timers)

- g) Systems coast down (with countdown timers)
- h) Start inhibit and inhibit mode (anti-recycle, vane motor switch open, excess motor current)
- i) Vanes closing before shutdown
- xii. System operating information, including the following as a minimum:
 - a) Return and leaving chilled water and condenser water temperatures
 - b) Evaporator and condenser refrigerant saturation temperatures
 - c) Sub-cooling refrigerant temperature
 - d) Evaporator and condenser pressure
 - e) Evaporator tube and condenser tube small temperature difference
 - f) Compressor discharge temperature
 - g) Oil sump temperature (if applicable)
 - h) Oil pump pressure differential (if applicable)
 - i) Percent of motor full load current
 - j) Input power
 - k) Kilowatt hours
 - l) Operating hours
 - m) Prerotation vane position
 - n) Refrigerant level position (condenser)
 - o) Motor winding temperature (each phase)
 - p) Average motor winding temperature
 - q) VSD – Output frequency
 - r) VSD – Output voltage (each phase)
 - s) VSD – Current (each phase)
 - t) VSD – Input current limit set point
 - u) VSD – Total supply KVA
 - v) VSD – Total power factor
 - w) VSD - Voltage total harmonic distortion (each phase)
 - x) VSD – Current total demand distortion (each phase)
 - y) VSD – DC bus voltage
 - z) VSD – DC bus current
 - aa) VSD – Input and output RMS voltages and currents (each phase)
 - bb) VSD – Internal ambient temperature
- xiii. Programmable setpoints including the following, as a minimum:
 - a) Chilled liquid temperature (setpoint and range)
 - b) Chilled liquid temperature cycling offset (shutdown and restart)
 - c) Motor current limit (%)
 - d) Pull-down demand (limit and time)

- xiv. Schedule function: Programmable six week schedule for starting and stopping the chiller, pumps and cooling tower.
- xv. Regional functionality: System language and units selection
- xvi. Warning messages including the following, as a minimum:
 - a) Real time clock failure
 - b) Condenser or evaporator transducer error
 - c) Refrigerant level out of range
 - d) Setpoint override
 - e) Condenser high pressure limit
 - f) Evaporator low pressure limit
 - g) MBC – High bearing temperature
 - h) MBC – Vibration
 - i) MBC – Landing counter high
 - j) MBC – Rotor elongation
- xvii. Safety Shutdowns: Trigger a safety shutdown for any of the following, as a minimum:
 - a) Evaporator – low pressure
 - b) Condenser – high pressure
 - c) Condenser – high pressure contacts open
 - d) Auxiliary safety – contacts closed
 - e) Compressor discharge – high or low refrigerant temperature
 - f) Oil – high temperature (if applicable)
 - g) Oil – high or low differential pressure (if applicable)
 - h) Oil – pump pressure setpoint not achieved (if applicable)
 - i) Control panel – power failure
 - j) Motor or starter – current imbalance
 - k) Watchdog – software reboot
 - l) Sensor – failure or out of range
 - m) Transducer – failure or out of range
 - n) MBC – internal fault
 - o) MBC – high bearing temperature or current
 - p) MBC – cable fault
 - q) MBC – speed signal fault
 - r) MBC – over speed fault
 - s) MBC – communication
 - t) MBC – rotor elongation
 - u) MBC – oscillator fault
 - v) MBC – power supply fault

- w) MBC – unauthorized rotation
 - x) MBC – no rotation
 - y) VSD – shutdown, requesting fault data
 - z) VSD – stop contacts open
 - aa) VSD – 105% motor current overload
 - bb) VSD – high rectifier heat sink temperature (indicate phase)
 - cc) VSD – high inverter heat sink temperature (indicate phase)
 - dd) VSD – pre charge lockout
 - ee) VSD – ground fault
 - ff) VSD – motor current total harmonic distortion (THD) fault
 - gg) VSD – motor synchronization fault
 - hh) VSD – inverter or rectifier program fault
- xviii. Safety Shutdowns: For each safety shutdown, indicate the following, as a minimum:
- a) System status and details
 - b) Day and time of shutdown
 - c) Cause of shutdown
 - d) Type of restart required
- xix. Cycling Shutdowns: For each cycling shutdown, indicate the following, as a minimum:
- a) Multiunit cycling – contacts open
 - b) System cycling – contacts open
 - c) Oil – low temperature (if applicable)
 - d) Oil – low temperature differential (if applicable)
 - e) Control panel – power failure
 - f) Leaving chilled liquid – low temperature
 - g) Leaving chilled liquid – flow switch open
 - h) Condenser – flow switch open
 - i) Motor controller – contacts open
 - j) Motor controller – loss of current
 - k) Power fault
 - l) Control panel – schedule
 - m) MBC - position
 - n) MBC – low frequency displacement
 - o) MBC – vibration
 - p) MBC – high amplifier temperature
 - q) MBC – high DC/DC temperature
 - r) MBC – no levitation

- s) MBC – serial communications fault
- t) VSD shutdown – requesting fault data
- u) VSD – stop contacts open
- v) VSD – initialization failed
- w) VSD – high instantaneous current (indicate phase)
- x) VSD – gate driver (indicate phase)
- y) VSD – single phase input power
- z) VSD – high or low DC bus voltage
- aa) VSD – DC bus voltage imbalance
- bb) VSD – pre charge: low DC bus voltage
- cc) VSD – pre charge: DC bus voltage imbalance
- dd) VSD – high internal ambient temperature
- ee) VSD – logic board power supply
- ff) VSD – low rectifier heat sink temperature (indicate phase)
- gg) VSD – low inverter heat sink temperature (indicate phase)
- hh) VSD – logic board processor
- ii) VSD – run signal
- jj) VSD – serial communications
- xx. Security Access: Through ID and password recognition defined by a minimum of three different levels of user capability:
 - a) View: prevent unauthorized changing of setpoints
 - b) Operator: allow local or remote control of chiller
 - c) Service: allow manual operation of pre-rotation vanes
- xxi. Chiller information screen including on-screen display of the following, as a minimum:
 - a) Model number
 - b) Chiller serial number
 - c) Control panel serial number
 - d) Manufacturer contract number
 - e) Design voltage
 - f) Refrigerant type
 - g) Starter type
 - h) Original factory chiller rating information
- xxii. Data tracking and trend display including on-screen graphical display of the following, as a minimum:
 - a) Parameters selected from a list of a minimum of 140 possibilities
 - b) Data collected once per second up to once per hour for each parameter
 - c) Data trend lines displayed for a minimum of 5 parameters at once

- xxiii. History: Store last ten shutdowns and display all system parameters at the time of shutdown.
- xxiv. Memory: Non-volatile type containing operating program and setpoints, capable of retention for 10 years without memory loss, despite AC or backup battery power loss.
- xxv. Terminal strip has be clearly numbered to accept field interlock wiring.

5.6.6 Compressor Motor Starter: Variable Speed Drive

- i. General: Variable Speed Drive (VSD) compressor motor starter to start motor and control motor speed be controlling the frequency and voltage of the electrical power supplied to the motor.
- ii. Drive type: Pulse width modulated (PWM) utilizing insulated gate bipolar transistors (IGBTs).
- iii. Control Logic: Independently control motor speed and pre rotation vane (PRV) position for optimum efficiency and operational stability. Base motor speed and PRV position on a minimum of 4 inputs: leaving chilled water temperature, return chilled water temperature, evaporator refrigerant pressure, condenser refrigerant pressure; Verify motor speed and PRV position and also use as inputs to the control logic.
- iv. Power Factor: At all loads and speeds, provide a minimum of a 0.95 power factor.
- v. Enclosure: IP42 or higher type with hinged access door with door interlock, lock and keys, and padlockable
- vi. Packaging: Factory mounted on chiller, piped to cooling circuit; wired to control panel and compressor motor; entire package (including active harmonic filter) shall be UL listed.
- vii. Cooling: Cool drive pole assembly components and internal ambient air via fluid-cooled, closed loop; all starter components accessible for service and replacement without opening the chiller's main refrigerant circuit.
- viii. Factory run test: Perform an electrical and mechanical run test of VSD starter prior to shipment to verify proper wiring and phasing.
- ix. Factory settings: Set starting design current and current overload settings prior to shipment.
- x. Harmonic Distortion: Provide a drive and chiller system with an integrated active harmonic filter mounted inside the starter cabinet. System must generate harmonic distortion levels less than the following, measured at the input side of the drive:
 - a) Current: 5% maximum current total demand distortion
- xi. Inrush amperage: Limited to the design full load amperage of the chiller.
- xii. Protective devices:
 - a) Electronic current-sensing overloads (1 per phase) – with indicating message on the control panel and reset button; shut down chiller upon detection of operating current exceeding 105% full load amperage.
 - b) High instantaneous current overload – with indicating message on the control panel and reset button; shut down chiller upon detection of

starting current exceeding 115% of design inrush starting current for 1 second.

- c) Phase rotation insensitivity
 - d) Single phase failure protection circuit with indicating light – shut unit down if power loss occurs in any phase at startup.
 - e) High temperature safety protection system on IGBTs with indicating light and reset button; via thermistors embedded on IGBT heat sinks – shut unit down if IGBT temperature exceeds acceptable limits.
 - f) Power fault protection for momentary power interruptions – interrupt power to the compressor motor within 4 line cycles upon detection of power interruptions longer than $\frac{3}{4}$ of a line cycle.
 - g) High and low line voltage protection.
- xiii. Control panel readouts: Display on the control panel and provide to BMS/IBMS via communication port the following as a minimum:
- a) Output frequency
 - b) Output voltage
 - c) Output current (each phase)
 - d) Input power (kW)
 - e) Energy consumption (kWh)
 - f) Elapsed running time
 - g) Three phase voltage total harmonic distortion (THD)
 - h) Three phase current total demand distortion (TDD)
 - i) Total unit power factor
 - j) Total supply KVA

5.7 CONDENSER

5.7.1 Scope

This chapter covers the requirements of condensers suitable for reciprocating, screw and centrifugal types of refrigeration machines for central air-conditioning and cold room applications.

5.7.2 Type

This section covers the following types of condensers: -

- i) Water cooled condensers, and
- ii) Air cooled condensers.

Evaporative condensers are excluded from the scope of these specifications.

5.7.3 Water Cooled Condensers

5.7.3.1 Rating

- i) Where a package condensing or water chilling unit is required, the condenser capacity shall match the compressor capacity specified in

the tender specifications. The condenser shall be selected for 4.2 degree C temperature rise of water through the condenser unless otherwise specified in the tender specifications.

- ii) The condenser shall be designed for a fouling factor of 0.0002 hr. sq.m. degree C difference / K.Cal unless otherwise specified in the tender specifications.
- iii) Unless otherwise specified, the condenser shall be designed for a entering water temperature of 32.2 degree C.

5.7.3.2 Material and Construction

- i) The condenser shall be horizontal, shell and tube type, designed, constructed and tested for the refrigerant specified in the tender specifications.
- ii) The shell of the condenser shall be made of MS of thickness not less than 8mm, with electric fusion welded seams. The shell capacity shall be such as to hold 1.25 times the refrigerant charge in the machine of which the condenser is a part, under pumped down conditions.
- iii) The end plates of condenser shall be made of MS of thickness not less than 25mm.
- iv) The condenser shall be designed for a working pressure on the refrigerant side suitable for the refrigerant offered, and on the water side for 10 kg./sq.cm. gauge.
- v) The tubes shall be of seamless hard drawn copper and finned, unless otherwise specified. The minimum wall thickness shall be 1.0 mm with root thickness of 0.63 mm below the fins.
- vi) Intermediate tube supports of steel shall be provided at not more than 1250 mm intervals to prevent sagging and vibration of the tubes. The condensers shall have water boxes designed for multi pass flow.
- vii) The tubes may be provided with special tabulating arrangement to improve heat transfer where such an arrangement is a standard design of the manufacturer.
- viii) The condensers shall be provided with removable heads on either side made of cast iron or steel with neatly machined surface for effective jointing with the shell for easy accessibility for cleaning/replacement of the tubes. Suitable baffles shall be incorporated to achieve the required number of passes. It should be possible to descale the tubes without disconnecting the water line connections, wherever marine water boxes have been specified in the tender documents.
- ix) The condenser shall be provided with baffle arrangement for preventing direct impingement of hot gas over the tubes and to enable even distribution of the gas over the tube bundles.

- x) The condenser shall include necessary provision for sub-cooling of the refrigerant where the refrigerating machine is selected with such sub-cooling requirement. The arrangement shall be such that the cold water entering the condenser first cools the liquid refrigerant in the sub-cooler.
- xi) The condenser shall be sand blasted from both inside & outside.

5.7.3.3 Connections and Accessories

The condenser shall be provided with the following connections and accessories and conforming to Section "Refrigerant Piping" where applicable: -

- a) Hot gas inlet and liquid outlet connections. The liquid line connections shall be provided with isolating valves.
- b) Water inlet and outlet connections
- c) Pressure relief device,
- d) Drain connection with valve for water side.
- e) Differential flow switch/ pressure switch/ flow switch / flow sensor in the water line(s).

5.7.3.4 Pressure Testing

- a) The condenser shall be tested at the works to 1.5 times the maximum working pressure for the refrigerant specified in the tender specifications.
- b) The water side of the condenser shall also be tested to a hydraulic pressure of 10 kg./sq.cm. in the works.
- c) Pressure test certificates shall be produced in respect of each condenser.

5.7.3.5 Treated Water for Condensers

All high-rise buildings using centralized cooling water system shall use soft water for the condenser and chilled water system.

5.7.4 Air Cooled Condensers

5.7.4.1 Material and Construction

- i) The condenser coil shall be fabricated of seamless hard drawn copper tubes and aluminium fins of 0.18 mm minimum thickness, fins spacing ranging from 3 to 5 fins per cm. The minimum wall thickness of tubes shall be 1.0 mm.
- ii) The coil shall normally be 2/3/4 rows deep unless otherwise specified.
- iii) The condenser shall be designed so as to hold 1.25 times the refrigerant charge in the system during the idle periods.
- iv) Suitable number and capacity of propeller type fans shall be provided for moving the air through the entire condenser coils. For more uniform flow over the condenser coil, the condenser shall be designed on the draw through principle. The air velocity over the condenser coil shall be maintained upto 200 mpm maximum.

5.7.4.2 Connections and Accessories

The following connections and accessories shall be provided on the condenser and conforming to Section "Refrigeration Piping" where applicable: -

- a) Hot gas inlet and liquid outlet connections. The liquid outlet connections shall be provided with isolating valves,
- b) Pressure relief device,

5.7.4.3 Pressure Testing

The pressure testing shall be done at 31 kg/sq.cm on refrigerant side.

5.7.4.4 Condenser Locations

Care shall be exercised in locating the condensers in such a manner that the heat sink is free of interference from heat discharge by devices located in adjoining spaces and also does not interfere with such other systems installed nearby.

Condensers should be located in such a manner that there is no restriction to the air flow around the condenser coils, there is no short-circuiting of discharge air to the intake side, and the heat discharge of other adjacent equipment is not anywhere the air intake of the condenser.

5.8 CHILLER

5.8.1 Scope

This chapter covers the requirements of chillers suitable for reciprocating, centrifugal and screw types of refrigerating machines for air-conditioning.

5.8.2 Types

This section covers the shell and tube type water chillers. These may be again of the following types: -

- a) For reciprocating type units the chiller shall be Direct expansion (DX) type
- b) For centrifugal type units the chiller shall be of Flooded type **or falling film type.**
- c) For screw type units the chiller shall be of Direct expansion (DX) type or Flooded type **or falling film type..**

5.8.3 Shell and Tube Type Water Chillers

5.8.3.1 Rating

- i) In a package water chilling machine, the chiller shall match the compressor capacity specified in the tender specifications. The chiller shall be selected for 4.4 degree C temperature drop of water through the chiller for reciprocating/**scroll** compressor & 5.5.deg C for centrifugal & screw type compressors.
- ii) The fouling factor shall be 0.0001 hr. sq.mtr. degree C temperature difference/K. Cal. unless otherwise specified in the tender specifications.

5.8.3.2 Material and Construction

- i) The water chiller shall be horizontal, shell and tube type, designed, constructed and tested for the refrigerant specified in the tender specifications.
- ii) The chiller shall be designed for a working pressure on the refrigerant side suitable for the refrigerant offered, and on the water side for 10 kg./sq.cm. gauge.
- iii) The end plates of chiller shall be made of MS of thickness not less than 25mm.
- iv) The shell of the chiller shall be made of MS of thickness not less than 8mm with electric fusion welded seams.
- v) The tubes shall be of seamless, hard drawn copper with a minimum tube wall thickness of 0.71 mm for plain tubes & minimum 0.63mm at the root of fins.
- vi) The tubes shall be plain for DX type chillers and may be either plain or internally finned for flooded type chillers as per manufacturer's design.
- vii) The tubes shall be rolled into grooves in the tube sheets and flared at ends.
- viii) Intermediate tube supports of steel or polypropylene shall be provided at spacing not less than 1250 mm for flooded type chiller and 500mm for DX type chiller to prevent sagging / vibration of tubes.
- ix) The flooded chillers shall have water boxes designed for multipass flow. The DX type chillers shall be provided with adequate number of properly spaced baffles so that the water passes through the tube bundle many times.
- x) The chiller shall be smooth finished with one coat of zinc chromate primer before the insulation is applied.
- xi) The chiller shall be sand blasted from both inside (before insertion of tubes) & outside.

5.8.3.3 Connections and Accessories

5.8.3.3.1 For DX Type Chiller

The DX type chiller shall be provided with the following connections and accessories and conforming to the Section "Refrigeration Piping" where applicable: -

- a) Refrigerant inlet and outlet connections
- b) Thermostatic / Electronic type expansion valve(s) with adjustable superheat control and external equalizer part,
- c) Line solenoid valve, or pilot solenoid valves as required.
- d) Water inlet and water outlet connections
- e) Drain connection with stop valve for water side only.
- f) Vent connection with valve.
- g) Flow switch in water line.

5.8.3.3.2 For Flooded Type Chiller

The flooded type chiller shall be provided with the following connections and accessories and conforming to section "Refrigeration Piping" where applicable:

- a) Refrigeration inlet and outlet connections.
- b) Liquid refrigerant float for level control/ expansion valve/ fixed or variable orifice.
- c) Pressure relief device.
- d) Charging connection with valve.
- e) Eliminator plate.
- f) Drain and vent connections with valves
- g) Water inlet and outlet connections
- h) Proper oil return system.
- i) Flow switch/pressure switch/differential flow switch/ flow sensor in the water line (s).

5.8.3.4 Pressure Testing

- a) The chiller shall be tested in the works to 1.5 times the maximum working pressure for the refrigerant specified in the tender specifications, or 21 kg./sq.cm. (Pneumatic), whichever is higher.
- b) The water side of the chiller shall also be tested to a hydraulic pressure of 10 kg./sq.cm. at the works.
- c) Pressure test certificates shall be produced in respect of each chiller.

5.8.3.5 Insulation

The insulation shall be done as per chapter 11.

5.8.4 Minimum Efficiency of Chillers

Cooling equipment shall meet or exceed the minimum efficiency requirements presented in the table below:

Equipment Class	Maximum Ikw/TR at ARI conditions	Minimum COP * at ARI conditions	Minimum IPLV	Test Standard
Air Cooled Chiller <530 kW (<150tons)	1.21	2.9	3.16	ARI 550/590-1998
Air Cooled Chiller ≥530 kW (≥150 tons)	1.15	3.05	3.32	ARI 550/590-1998
Centrifugal Water Cooled Chiller <530 kW (<150tons)	0.61	5.8	6.09	ARI 550/590-1998
Centrifugal Water Cooled Chiller ≥530 kW and <1050 kW (≥ 150 tons and <300 tons)	0.61	5.8	6.17	ARI 550/590-1998
Centrifugal Water Cooled Chiller ≥1050 kW (≥300 tons)	0.56	6.3	6.61	ARI 550/590-1998
Reciprocating Compressor, Water Cooled Chiller all sizes	0.84	4.2	5.05	ARI 550/590-1998
Rotary Screw and Scroll Compressor, Water cooled chiller <530 kW (<150 tons)	0.75	4.7	5.49	ARI 550/590-1998
Rotary Screw and Scroll Compressor, Water cooled chiller ≥530 kW and <1050 kW (≥ 150 tons and <300 tons)	0.65	5.4	6.17	ARI 550/590-1998
Rotary Screw and Scroll Compressor, Water cooled chiller ≥1050 kW (≥300 tons)	0.61	5.75	6.43	ARI 550/590-1998

5.9 Chiller Plant Optimizer:

Chiller Plant Optimizer shall be provided in the plant room for Chilling Unit (s), Chilled Water Pumps /Primary Chilled Water Pumps, Condenser Water Pumps and Cooling Towers . The Chiller Plant Optimizer shall be of the same manufacturer/ OEM as that of the Chilling Unit.

5.10 REFRIGERANT PLUMBING

5.10.1 Design aspects of Refrigerant Plumbing

- i) Refrigerant piping shall be designed and installed so as to:
 - a) ensure circulation of adequate refrigerant at all loads.
 - b) ensure oil return to crank case of compressor positively and continuously.
 - c) keep pressure losses within limits, especially in suction lines.

- d) prevent oil/liquid refrigerant from entering the compressor when the compressor is working as well as when it has stopped.
 - e) prevent trapping of oil in evaporator or suction lines, which may return to the compressor in the form of slug.
- ii) Hot gas lines:
- a) Oil shall be entrained and carried by hot gas under all load conditions likely to be encountered in normal operation.
- iii) Liquid Lines :
- a) Liquid lines shall be designed to ensure that flashing of liquid refrigerant does not occur by minimising the pressure drop suitably, by avoiding long vertical risers, and appropriate sub cooling.
 - b) Each liquid line shall be provided with a permanently installed refrigerant drier of throw away or rechargeable type. The drier shall be installed in a valved line.
 - c) Flow indicator (moisture indicating type) shall be installed on all liquid lines.
- iv) Suction Lines :
- a) Oil shall be entrained and carried by the suction gas under all conditions of load likely to be encountered in normal operation.
 - b) Piping shall be designed for a suitable velocity of refrigerant (similar to hot gas line) to ensure that oil will not separate from the gas and drain to the compressor in slugs.
 - c) The refrigeration system shall be equipped with controls for pump down system so that the evaporator and suction line are emptied before the compressor shuts off, thus preventing liquid refrigerant and oil from entering the compressor when restarted.
 - d) Refrigerant lines shall be sized to limit pressure drop between evaporator and condensing unit to less than 0.2 kg. per sq.cm. (3 psi).
- v) Isolating valve shall be provided to enable isolation of each compressor in case of multiple compressor units (as built in valves), strainer, drier and any other components as may be required for proper operation and maintenance.
- vi) Thermostatic / Electronic type expansion valve/ float valve shall be provided in refrigerant circuit of DX system/ flooded system.

5.10.2 Material

- i) Refrigerant plumbing for reciprocating type refrigeration plant and packaged type AC plants shall be with copper tubes, with tube thickness conforming to L type to ATM standards. The tubes shall be bright annealed copper upto and including 15 mm size. The tube shall be suitable for the duty involved.

- ii) Fittings like bends, tees, sockets etc. shall be of wrought copper or forged brass and shall be suitable for the duty involved. Flare type compression fittings of forged brass shall be allowed upto 15 mm piping size. Tubes upto and including 15 mm size may be bent to form 90 degree bends with inside radius not less than 3 tube diameters. For bigger sizes, bend fittings as mentioned above must be used.
- iii) Where specified in the tender specification, mild steel may be provided for refrigeration piping, with seamless MS tubes and fittings of heavy class conforming to IS: 1239. All liquid lines and instruments lines shall however be of copper only.
- iv) Refrigerant plumbing for centrifugal/ screw type chilling machine shall be of mild steel or wrought iron / copper to manufacturer's standards.
- v) Valves shall be of the packed, back-seating type for both copper and MS refrigerant plumbing work, and these shall be of forged or cast brass construction.

5.10.3 Pressure Testing:

- i) After completion of the piping installation, the entire chilling unit shall be pressure tested with dry nitrogen or any other inert gas at the following pressures for the particular refrigerant to be used: -

Refrigerant	Test pressure (Kg./Sq.cm. (Gauge))	
	High pressure side	Low pressure side
R-134a	20	8

This test shall be carried out as follows: -

- a) The system shall be charged with nitrogen or inert gas to 1.0 Kg./sq.cm. gauge and all joints shall be checked for leakage with a mixture of four part water, one part liquid soap and a small amount of glycerin. Leaks shall be marked, pressure released and repairs done. Brazed joints, which leak, shall be opened and redone. These shall not be repaired by addition of brazing alloy to the joints.
- b) The system shall now be charged with nitrogen or the inert gas to the pressure specified in the above table and the process of locating leaks and repairs shall be repeated.
- ii) Final pressure test :

After all the leaks have been repaired, the system shall be retested with the test pressure maintained for a period of not less than 8 hours. No measurable drop in pressure should be detected after the pressure readings are adjusted for temperature changes. Pressure gauges, controls and compressors may be valved off during pressure testing.

5.11 MICROPROCESSOR CONTROLLER

- 5.11.1 Each chilling unit shall be complete with a microprocessor based interactive control console in a locked enclosure factory mounted (directly on the unit), prewired with all operating and safety controls and tested.
- 5.11.2 It will provide start, stop, safety, interlock, capacity control and indications for operation of the chiller units through a alphanumeric / graphical display.
- 5.11.3 Controls shall provide to view and change digital programmable essential set points, cause of shutdown and type of restart required.
- a) Leaving chilled water temperature,
 - b) Percent current limit.
 - c) Remote reset temperature range.
- 5.11.4 All safety and cycling shutdowns shall be enunciated through the alphanumeric/ graphical display and consist of day, time, cause of shutdown and type of restart required.
- 5.11.5 Cycling shutdown shall include low leaving chilled water temperature, chiller/ condenser water flow interruption, power fault, internal time clock and anti-recycle.
- 5.11.6 Safety shutdowns shall include low oil pressure, high compressor discharge temperature, low evaporator pressure, motor controller fault and sensor malfunction.
- 5.11.7 The default display screen shall indicate the following minimum information
- i) date and time
 - ii) return and leaving chilled water temperatures
 - iii) return and leaving condenser water temperatures
 - iv) differential oil pressure
 - v) percent motor rated current
 - vi) evaporator & condenser refrigerant saturation temperatures
 - vii) chiller operating hours (hour run) and
 - viii) number of compressor starts
 - ix) oil sump temperature (not required for reciprocating compressor)
 - x) status message
- 5.11.8 Security access shall be provided to prevent unauthorised change of set points, to allow local or remote control of the chiller and to allow manual operation of the prerotation vanes and oil pump.
- 5.11.9 The chiller shall be provided with ports compatible with **open protocol** building management system offered, to output all system operating information, shutdown/ cycling message and a record of last four cycling or safety shutdowns to a remote printer (option) . The control centre shall be programmable to provide data logs to the printer at a set time interval.
- 5.11.10 Control centre shall be able to interface with an automatic controls system to provide remote chiller start/ stop; reset of chilled water temperature, reset of current limit, and status messages indicating chiller is ready to start, chiller is operating, chiller is shut down on a safety requiring reset and chiller is shut down on a recycling safety.

5.11.11 The microprocessor control system shall include the interlocking of compressor motor with chilled and condenser water flows, guide vane position of compressor in case of centrifugal units and lubricating oil pump pressure.

5.11.12 On initiation of start, the microprocessor control system shall check all pre-start safeties to verify that all prestart safeties are within limits. (If one is not, an indication of the fault will be displayed and the start aborted).

5.12 INSTALLATION

The complete chilling unit shall be installed over a RCC foundation and shall be adequately isolated against transmission of vibrations to the building structure. Special attention shall be paid to the alignment of the driving and driven shaft. Final alignment shall be checked at site in presence of the Engineer-in-charge using a dial indicator. Necessary foundation bolts, nuts, leveling screws etc wherever required for mounting the unit shall be provided by the contractor.

5.13 PAINTING

The equipment shall be supplied as per manufacturer's standard finish painting.

CHAPTER- 6

FACTORY BUILT AIR HANDLING UNIT (AHU), FAN COIL UNIT (FCU) AND OTHER AIR DISTRIBUTION SYSTEMS

6.1 SCOPE

This chapter covers the detailed requirements of factory built double skin air handling unit (AHU), single skin fan coil unit (FCU) and other air distribution systems like chilled beam, floor radiant cooling, and variable air volume systems for central air-conditioning system as well as for central heating systems.

6.2 FACTORY BUILT AIR HANDLING UNIT (AHU)

6.2.1 Type

The air handling unit shall be of double skin construction, draw through type in sectionalised construction consisting of blower section, coil section, humidification section (where specified), filter section and insulated drain pan. Unless otherwise specified, the unit shall be horizontal type. Vertical type units are generally used whenever there is a space constraint.

The use of Ceiling Suspended AHUs should be discouraged due to maintenance problems.

6.2.2 Rating

- i) The capacity of the cooling/heating coil, the air quantity from the blower fan and static pressure of blower fan shall be as laid down in the tender documents. Where these parameters as calculated by the tenderer exceed the specified values, the coils and the blower fan shall satisfy these calculated values.
- ii) The coil shall be designed for a face velocity of air not exceeding 155 m/min.
- iii) The requisite static pressure demanded by the air circuit shall be developed by the fan at the selected operating speed. The static pressure value shall not in any case be less than 40 mm water gauge in normal cases, not less than 65 mm water gauge where microvee filters are also used and not less than 100 mm water gauge where absolute filters are also used. The fan motor HP shall be suitable to satisfy these requirements and the drive losses.
- iv) The air outlet velocity from the blower fan shall not exceed 610 m/min.
- v) Noise level at a distance of 2M from AHU shall not exceed 75 dBA.

6.2.3 Material and Construction

6.2.3.1 Housing/ Casing

- i) The housing/ casing of the air handling unit shall be of double skin construction. The housing shall be so made that it can be delivered at site in total/ semi knocked down conditions depending upon the requirements. The main framework shall be of extruded aluminium hollow structural sections. The entire framework shall be assembled using mechanical joints to make a sturdy and strong framework for various sections. For 100% fresh air application framework shall be made of thermal break hollow extruded aluminium profile.
- ii) Double skin panels shall be 25mm thick, made of 0.8mm pre-plasticized and pre-painted with PVC guard, GSS sheet on outside and 0.8mm galvanized sheet inside with Polyurethane foam insulation of density not less than 38 kg/cu. m injected in between by injection moulding machine. These panels shall be bolted from inside/ screwed from outside on to the framework with soft rubber gasket in between to make the joints airtight. The gaskets shall be inserted within groove in extruded aluminium profile of the framework. For units installed outdoor, the thickness of double skin panels shall be minimum 40 mm.
- iii) Frame work for each section shall also be bolted together with soft rubber gasket in between to make the joints air tight. Suitable doors with nylon handles, aluminium die-cast powder coated hinges & latches shall be provided for access to various panels for maintenance. However, AHU in the form of complete single unit shall also be acceptable with access door(s) for maintenance to various sections. The entire housing shall be mounted on galvanised steel channel frame work made out of G.I. sheet of thickness not less than 2mm. For higher capacity AHUs hot dip galvanized steel channel framework made of minimum 3 mm thick G.S. sheet shall be used.

6.2.3.2 Drain Pan

Drain pan shall be made out of minimum 1.25 mm **stainless steel** sheet externally insulated with 10mm thick closed cell Polyethylene foam insulation **or nitrile rubber or PUF** with necessary dual slope to facilitate fast removal of condensate. Necessary supports will be provided to slide the coil in the drain pan.

6.2.3.3 Cooling / Heating coil

- i) The coil shall be made from seamless solid drawn copper tubes. The minimum thickness of tube shall be 0.5 mm for cooling / heating / heating-cum-cooling coils.
- ii) The depth of the coil shall be such as to suit the requirements, viz. re-circulated air applications, or 100 % fresh air applications and the bypass factor required shall be specified in the tender specifications. The coil shall be 4 or 6 rows deep for normal re-circulated air application and 8 rows deep for all outdoor air application, unless otherwise specified in the tender specifications. In case of 8 rows deep coils, it shall be made of 2x4 rows deep coils with a spacing of 200mm between the two coils, access door and independent drain pan.
- iii) U bends shall be of copper, jointed to the tubes by brazing, soft soldering shall not be used.

- iv) Each section of the coil shall be fitted with flow and return headers to feed all the passes of the coil properly. The headers shall be of copper and shall be complete with water in/out connections, vent plug on top and drain at the bottom. The coil shall be designed to provide water velocity between 0.6 to 1.8 m/s in the tubes.
- v) The fins shall be of aluminium. The minimum thickness of the fins shall be 0.15 mm nominal. The no. of fins shall not be less than 4.7 per cm length of coil. Fins may be of either spiral or plate type. The tubes shall be mechanically expanded to ensure proper thermal contact between fins and tubes. The fins shall be evenly spaced and upright. The fins bent during installation shall be carefully realigned. For coastal areas fins shall be phenolic coated and for 100% F.A. application fins shall be hydrophilic type.
- vi) The coil shall be suitable for use with the refrigerant specified or with water as the case may be. Refrigerating coils shall be designed for the maximum working pressure under the operating conditions. Water coils shall be designed for a maximum working pressure of 10 kg./sq.cm.
- vii) Shut off and regulating valves at the inlet and outlet of water shall be provided. In the case of DX coils, solenoid valve and expansion valves shall be provided at the inlet of coil.

6.2.3.4 Supply Air Fan and Drive

- i) The supply air fan shall be AMCA certified centrifugal type with forward/backward curved blades double inlet double width type. For static pressure upto 65mm forward curved blades shall be used and for higher sizes backward curved blades shall be used.
- ii) The fan housing of Galvanised sheet steel and the impellers shall be fabricated from heavy gauge steel sheet as per approved manufacturers standard. The side plates shall be die formed for efficient, smooth airflow and minimum losses. Fan impeller shall be mounted on solid shaft supported to housing using heavy duty ball bearings. Fan housing and motor shall be mounted on a common extruded aluminium base mounted inside the fan section on anti-vibration spring mounts or cushy- foot mount. The fan outlet shall be connected to casing with the help of fire retardant fabric.
- iii) The fan impeller assembly shall be statically and dynamically balanced.
- iv) The fan shall be fitted with vee belt drive arrangement consisting of not less than two evenly matched belts. Belts shall be of oil resistant type. Adequate adjustments shall be provided to facilitate belt installation and subsequent belt tensioning by movement of the motor on the slide rails. A readily removable door guard shall be provided.
- v) The fan motor shall be totally enclosed fan cooled squirrel cage induction motor with IP-54 protection & selected for quiet running. The motor shall be suitable for operation on $415 \pm 10\%V$, 3 phase, 50 Hz., A.C. supply. The fan motor shall be premium efficiency IE3 class , as

per IS 12615. **The motor shall be suitably designed for use with variable frequency drive.**

- vi) **All AHU fan motors shall be provided with variable frequency drive where VAVs (Variable Air Volume control) are provided in the ducts.**
- vii) For energy efficiency of system, **where VAVs (Variable Air Volume control) are provided in the ducts**, VFD, in place of starter **shall** be provided in Air Handling Units. VFD with harmonics filters should be specified. Whenever VFD is fitted, direct shaft driven motors are normally used.

6.2.3.5 Air Filters

The air used in an air-conditioning system must be filtered to maintain a clean atmosphere in the conditioned space. The concentration of contaminants in the air and the degree of cleanliness required in the conditioned space will determine the type of filter or filters that must be used.

6.2.3.5.1 Type of filters

i) Pre-filters :

Cleanable metallic viscous type filter made out of aluminium wire mesh or of dry cleanable synthetic type minimum 50mm thick, shall be provided on the suction side of AHU as a standard equipment with the unit. These filters shall have the efficiency of 90% down to 10 micron particle size. When these filters become loaded or full of dirt, it is removed from service and replaced by another filter. The dirty filter can then be washed in a cleaning solution in a tank, dried and then given a bath of viscous oil. Face velocity across these filters shall not exceed 155 MPM.

ii) Dry fabric (fine) filters

These filters shall have efficiency of 99% down to 5 micron particle size as per EU 7 standard. These filters are provided only where special cleanliness standard is required such as for library, lab, wards, OTs etc. These are provided on the discharge side of AHU after fan section and are always backed by pre-filters provided on the suction side of AHU. Face velocity across these filters shall not exceed 155 MPM. These filter shall be separately measured and paid for.

iii) Absolute (HEPA) filters

These filters shall have efficiency of 99.97% upto 0.3 micron particle size as per EU 13 standard & are required for applications like operation theatre, micro-labs etc. These are also provided in the AHU after fan section or at terminal point and always must be backed by fine filters & pre filters. These filters after they become dirty, can not be reused and have to be thrown away. Face velocity across these filters

shall not exceed 155 MPM. These filters shall be separately measured & paid for.

6.2.3.5.2 General Construction of filters

- i) Each AHU shall be provided with a factory assembled filter section containing pre-filters made of cleanable metal viscous filters made of corrugated aluminium wire mesh, or dry cleanable synthetic filters. These shall be minimum 50 mm thick with a frame work of aluminium.
- ii) The filter area shall be made up of panels of size convenient for handling. The filter panels shall be held snugly within suitable aluminium framework made out of minimum 1.6 mm aluminium sheet with sponge neoprene gaskets by sliding the panels between the sliding channels so as to avoid air leakage.
- iii) In order to indicate the condition of these filters while in operation, a manometer shall be provided to indicate the pressure drop across the fine filters and absolute filters.
- iv) Special filters, if any specified in the tender specifications shall be provided in addition to the above filters. In that event, the latter shall function as pre-filters.
- v) Each fine and Hepa filter shall carry test certificate from manufacturer.

6.2.3.6 Humidification Arrangement

Wherever specified in the tender specifications, humidification arrangements shall be provided with the AHUs. This shall consist of one of the following arrangements. The particular arrangement to be followed shall be specified in the tender specifications.

6.2.3.6.1 Pan type humidification arrangement

Pan type humidifier shall be complete with stainless steel sheet (minimum 2mm thick) tank duly insulated, steam outlet nozzle, top open able with stainless steel bolts, immersion heaters, low level cut out, humidistat, thermostat; safety stat, float valve & sight glass etc. The tank shall be insulated with 50mm thick expanded polystyrene (TF quality) slabs & finished with 0.5mm thick G.I. sheet.

6.2.3.6.2 Ultrasonic humidification arrangement

These humidifiers consume lesser energy as compared to Pan type humidifiers. Use of this type may be done where the cost is comparable to other types.

An ultrasonic humidifier uses a metal diaphragm vibrating at an ultrasonic frequency to create water droplets that silently exit the humidifier in the form of a cool fog. Ultrasonic humidifiers use a piezoelectric transducer to create a high frequency mechanical oscillation in a film of water. This forms an extremely fine mist of droplets about one micron in diameter, which is quickly evaporated into the air flow. Unlike the humidifiers that boil water, these water droplets will contain any impurities that are in the reservoir, including minerals from hard water (which then forms a difficult-to-remove sticky white dust on

nearby objects and furniture). Any pathogens growing in the stagnant tank will also be dispersed in the air. Ultrasonic humidifiers should be cleaned regularly to prevent bacterial contamination from being spread throughout the air.

The amount of minerals and other materials can be greatly reduced by using distilled water, though no water is absolutely pure. Special disposable demineralization cartridges may also reduce the amount of airborne material,

6.2.4 Instruments and Valves

The following instruments shall be provided at the specified locations in the AHUs for the chilled water / hot water system: -

- i) Pressure gauges at the inlet and outlet of the coil with tubing and gauge cock.
- ii) Stem type thermometers at the inlet & outlet of coil with tubing & gauge cock.
- iii) Butterfly valve at the inlet and outlet of coil.
- iv) Balancing valve at the outlet of coil.
- v) Y-strainer at the inlet of coil.
- vi) Motorised 3-way diverting/ mixing valve along with proportionate thermostat.

6.2.5 Controls

These shall be as per details given under chapter 12 'Controls'.

6.2.6 Insulation

The insulation of casing shall be as per para 6.2.3.1 (ii) & that of drain pan shall be as per 6.2.3.2.

6.2.7 Installation

The air handling unit shall be so installed as to transmit minimum amount of vibration to the building structure. Adequate vibration isolation shall be provided by use of rubber/ neoprene pads and/or vibration isolation spring mountings.

6.3 FAN COIL UNITS

6.3.1 General

The fan coil units shall be floor/ wall/ ceiling mounted draw through type complete with finned coil, fan with motor, insulated drain pan, cleanable air filters and fan speed regulator and other controls as described.

6.3.2 Casing

The casing shall be fabricated out of minimum 1.25mm thick G.S.S. sheet.

6.3.3 Cooling coil

The coil shall be of seamless copper tubes with aluminium fins. The fins shall be uniformly bonded to the tubes by mechanical expansion of the tubes. The

coil circuit should be sized for adequate water velocity but not exceeding 1.8 m/s. The air velocity across the coil shall not exceed 155 m/min.

6.3.4 Fan

This shall consist of two light weight aluminium impellers of forward curved type, both statically and dynamically balanced, along with properly designed GI sheet casings.

The two impellers shall be directly mounted on to a double shaft, single phase multiple winding motor capable of running at three speeds.

6.3.5 Drain Pan

Drain pan shall be fabricated out of minimum 1.00 mm thick stainless steel sheet covering the whole of coil section and extended on one side for accommodating coil connection valve etc. and complete with a 25mm drain connection. The drain pan shall be insulated with 10mm thick closed cell polythylene foam insulation and jacketed from outside with single piece moulded FRP tray.

6.3.6 Air Filter

The filter shall be cleanable type 15mm thick with 90% efficiency down to 10 micron of dry cleanable synthetic type to be mounted behind the return air grill in the unit casing.

6.3.7 Speed control

A sturdy switch shall be provided with the unit complete with wiring, for ON/OFF operation and with minimum three speed control of the fan.

6.3.8 Automatic controls

Each unit shall have a room type thermostat and a solenoid valve. The valve shall be fixed at a convenient location. The thermostat shall be mounted along with the speed control switch on a common plate. The plate shall clearly indicate the fan positions.

The water valves on inlet line shall be of gun metal ball type with internal water strainers, having BSP female pipe thread inlet and flare type male pipe thread outlet connection. The valves on return line shall be as above, but without the water strainer.

6.3.9 Water Connections

The water lines shall be finally connected to the coil of the fan coil unit, by at least 300mm long, type 'L' seamless solid drawn copper tubing, with flare fittings and connections.

6.4 INSULATION

The drain pan shall be insulated as per para 6.3.5.

6.5 PAINTING

All equipment shall be supplied as per manufacturer's standard finish painting.

6.6 CHILLED BEAMS

6.6.1 System description

Chilled beam system is an air conditioning system for cooling, heating and ventilation in spaces for good indoor climate and individual space control. The chilled beam system is an air/water system that utilizes the heat transfer properties of water and provides comfortable indoor climate energy efficiently.

6.6.2 System mounting

The Chilled Beams shall be ceiling mounted and consisting of a heat exchanger, a number of nozzles and a plenum in which dehumidified air is supplied.

6.6.3 System operation

Chilled beam systems are designed to use the dry cooling principle operating with conditions in which condensation is prevented by control applications.

6.6.3.1 Ventilation

Ventilation using active chilled beams is an efficient mixing ventilation application that results in uniform air quality. Supply air is diffused from linear slots on either both sides or on only one side of the chilled beam. Ventilation in passive chilled beam systems is typically arranged using mixing ventilation with ceiling or wall diffusers. Alternatively, floor diffusers can be used.

6.6.3.2 Cooling

Active chilled beams use the primary air to induce and recirculate the room air through the heat exchanger of the unit, resulting in high cooling capacities and excellent thermal conditions in the space. Passive beam operation is based on free convection in the heat exchanger and supply air distribution is realized with separate diffusers.

6.6.3.3 Heating

Integration of heating into chilled beams is recommended when heating capacity is low enough (200-300 W/m) and the U-value of the windows prevent a down-draught under the window.

6.6.4 Typical input values and operation range

- i) Room temperature: 23-25 °C
- ii) Supply air temperature: 16-19 °C
- iii) Water inlet temperature: 14-16 °C
- iv) Target duct pressure level: 70 -120 Pa
- v) Target water flow rate: 0.02-0.08 kg/s
- vi) Sound pressure level < 35 db (A)

- vii) Outdoor airflow rate/ floor area: 1.5-2.5 (6) l/s/m²
- viii) Outdoor airflow rate/ effective length: 5-12 l/s/m
- ix) Cooling capacity / floor area: 120 (200) W/m²
- x) Cooling capacity / beam effective length: 350 (500) W/m
- xi) Heating capacity / floor area: 60 (80) W /m²
- xii) Heating capacity / beam effective length: 200 (300) W/m

6.6.5 Technical specifications

- i) The active chilled beam shall have an integral recirculation air path through the perforated front panel. The induced room air flow rate shall be manually adjustable via three setting positions without influencing the primary air supply flow rate. The airflow rate of the chilled beam shall be adjustable without plugging or changing the nozzles.
- ii) The primary air flow rate shall be adjustable over a wide range via a supply air unit integrated into the chilled beam.
- iii) Outdoor air flow rate control shall not have any effect on coil cooling and heating capacities.
- iv) The beam with adjustable air flow rate shall have only one duct connection. The appearance of the chilled beams with constant air flow and variable air flow rate shall be the same.
- v) The front panel shall be openable from either side in order to allow general maintenance and cleaning. The front panel shall be removable without any special tools.
- vi) The air supply to the room space shall be either unidirectional or bi-directional.
- vii) The position of the duct connection shall be changeable without the use of any special tools.
- viii) The frame, front, and side panels shall be made of galvanized steel plate.
- ix) All visible parts shall be white/ painted to match the ceiling colour.
- x) All pipes shall be manufactured from copper, and connection pipes with a wall thickness of 0.9-1.0 mm.
- xi) The fins shall be manufactured from aluminium.
- xii) Optionally, heating shall be incorporated within the heat exchanger by means of two 10-mm pipes, connected in series.
- xiii) All joints shall be soldered and factory pressure-tested.
- xiv) The pipework's operation pressure should be 1.0 MPa.
- xv) The active chilled beam shall have an air flow adjustment damper as an option and a measurement tap to allow air flow measurement.
- xvi) As an option, an exhaust valve shall be integrated into the chilled beam.
- xvii) In tropical countries like India, The chilled beam should have drain pan and pump to collect and dispose-off the condensate.

6.7 VARIABLE AIR VOLUME SYSTEM

The Variable air volume system uses Variable speed drives for fan volume control providing a great deal of flexibility for multiple zones in temperature control and efficiency, good control of ventilation air quantities, and opportunity for higher levels of filtration.

6.7.1 VAV Diffusers

The modules shall vary the supply air volume to provide both VAV heating and VAV cooling in individual rooms controlled through a room temperature

sensing thermostat in each room. It shall sense room temperature and vary the supply air when cooling.

6.8 RADIANT COOLING SYSTEM

6.8.1 Scope

This section describes the basic requirement of Radiant cooling system with embedded pipes inside the slab during casting of the floors/slab of a building.

6.8.2 Principle

The principle of Radiant cooling system is based on the utilization of the thermal mass of building components. Due to the large thermal storage mass of walls, cool room temperatures can comfortably be enjoyed even in the summer when the outside temperature is high.

The heat loads arising in the room are absorbed by cool solid building elements.

The storage characteristic of solid concrete parts is utilised by polymers pipes carrying cooling realising "limitless" thermal storage.

6.8.3 Features

- i. The pipe shall be of high-quality and all central components of laying systems shall be pressure-resistant, rugged and impermeable to oxygen.
- ii. For subsurface heating and cooling permanently sealed compression sleeve jointing technique shall be used.
- iii. The system shall be corrosion resistance.
- iv. The pipe shall have good abrasion resistance.
- v. Even temperature profiles shall be maintained.
- vi. The pipe material shall be such that minimum noise gets transmitted along the pipe.

6.8.4 System advantages and benefits

- i. Easy and quick assembly
- ii. Comfortably temperature-controlled floor surface
- iii. Minimal air speeds
- iv. No upsetting of dust
- v. Optimum room arrangement flexibility
- vi. Low operating temperatures
- vii. Suitable for heat pump and solar power systems
- viii. No maintenance costs

- ix. Toxicologically and physiologically harmless.

6.8.5 Implementation

- i. The cooling/heating is highly economical due to the high proportion of radiated cool/ heat, a favourable room temperature profile and low maintenance costs.
- ii. The system shall have the following features
- iii. Apart from the low installation and operating costs, floor space shall be completely used as the cooling/heating is integrated in the concrete floor.
- iv. Competent support in the planning, appropriation of work and in assigning specialised companies with onsite support at the building site shall be provided during the installation of the system
- v. An ideal temperature profile shall be produced and heat trapped under the roof shall be reduced
- vi. The heating/cooling system shall have no effect on the dynamic and static properties of the sprung floor.

6.9 GEOTHERMAL BASED AIR COOLING SYSTEM

6.9.1 Principle

The principle of Air duct tunnel system is based on the utilization of the geothermal energy present in the ground. Due to the temperature difference between the ground(below certain depth) and air present in the atmosphere the air when taken through a lesser temperature of the ground exchanges heat/losses heat to the ground and becomes cool. This cooled air is then circulated in the building and give the comfortable cooled air into the area.

6.9.2 Features

The ground's ability to store energy is used to achieve on energy efficient controlled ventilation solution. An antimicrobial inner layer shall be provided to ensure quality supply of air inside the building.

6.9.3 Advantages and benefits

The unique advantage with this system is that the air duct tunnels in summer provided cooled air whereas in winter provides warm air to the building. Other benefits should include

- i. Easy and quick assembly
- ii. Comfortably temperature-controlled using ground heat exchange.
- iii. Anti microbial layer for non microbes formation.
- iv. Minimal air speeds
- v. Inbuilt filtration option.
- vi. No upsetting of dust
- vii. Suitable for heat pump and solar power systems
- viii. No maintenance costs
- ix. Corrosion resistance: no pitting
- x. Does not tend to accumulate deposits
- xi. Polymer pipe material gives high load bearing capacity.
- xii. Toxicologically and physiologically harmless.

6.9.4 Support and process

Air duct tunnel system design is highly specific to the site conditions and output requirements however following steps are followed for installation of the same.

- i. Pipe transportation and storage
- ii. Digging the trench and installation of the pipes
- iii. Lowering pipes into trenches and its connection.
- iv. Cutting of pipe length
- v. Visual inspection and leak tightness
- vi. Embedment and main backfill
- vii. Compaction

6.9.5 Design

Since every geological location has unique soil conditions, air tunnel system needs to be designed and supplied as per the output requirements of the building based on the soil test report or soil conditions.

CHAPTER- 7

COOLING TOWERS

7.1 SCOPE

This chapter covers the general requirements of cooling towers for packaged units, central air-conditioning plants and cold rooms.

7.2 TYPE

The cooling tower shall be of Mechanical draft type. Fan on Mechanical draft towers may be on the inlet air side or exit air side. In case of former it is called forced draft type and in case of later it is called Induced draft type. On the basis of direction of air flow and water flow, Mechanical draft cooling tower can be counter flow or cross flow type as per the manufacturer design.

This may be of any of the following construction as may be specified in the tender specifications:-

- a) In wooden construction with wood or PVC fill and RCC basin,
- b) In fibre glass reinforced plastic (FRP) construction with PVC fill and FRP basin,
- c) In masonry construction.

The mechanical draft cooling towers of wooden construction and masonry construction, being un-common now, have been excluded from the scope of these specification.

7.3 DESIGN

- i) Rating :

The cooling tower shall be rated for the heat rejection capacity specified in the tender specifications. **All cooling towers shall be certified by CTI (Cooling Tower Institute).**

- ii) Range:

The Cooling tower shall be designed to cool the requisite quantity of water through 4.2 degree C or as specified in the tender specifications, against the prevailing wet bulb temperature.

- iii) Wet Bulb approach:

The cooling tower shall be selected for a wet bulb approach of not more than 2.77 degree C.

- iv) Outlet temperature:

The cold water temperature from the cooling tower shall match the entering temperature for which the condenser selection is made.

- v) Flow rate:
The water flow rate through the cooling tower shall match that through the condenser.
- vi) Multi cell design :
The induced draft cooling tower shall be of one or more cells.
- vii) Drive Motor : The fan motor shall be premium efficiency IE3 class , as per IS 12615.

7.4 MATERIAL AND CONSTRUCTION

Fibreglass Reinforced Plastic (FRP) Cooling tower

- i) The structural framework of the cooling tower including all members shall be designed for the load encountered during the normal operation of the cooling tower and its maintenance. The structure shall be rugged and rigid to prevent distortion and shall include tie arrangements as may be necessary.
- ii) The cooling tower shall be induced draft type, with FRP casing in square/ rectangular/ octagonal/ circular shape, and with an FRP basin to match the shape of the casing.
- iii) The air intake shall be from openings all along the circumference of the casing near its base in case of circular shape. Air Intake shall be along the sides in case of square or octagonal/ rectangular cooling tower. These openings shall be covered with hot dip galvanised expanded metal mesh screens.
- iv) The basin shall have a holding capacity adequate for operation for atleast 30 minutes without addition of make-up water to the basin. The construction should be such as to eliminate the danger of drawing air into the pump when operating with minimum water in the basin.
- v) The basin fittings shall include the following: -
 - a) Bottom /side outlet,
 - b) Drain connection with valve,
 - c) Ball type automatic make-up connection with valve,
 - d) Overflow connection,
 - e) Bleed off with valve, from inlet header to overflow pipe.
- vi) The supporting framework for the tower casing and the water basin shall be made of hot dip galvanised steel and it shall be further protected with epoxy painting.
- vii) The filling shall be of PVC. Thickness of PVC fills shall not be less than 0.2mm. These shall be of such construction as to provide low air resistance, large wetted surface for a high heat transfer efficiency, and easy replace ability.
- viii) The water distribution may be either through self-rotating or fixed type sprinklers or through balancing, sub balancing and spreader troughs (unpressurised system) “open gravity type with polypropylene nozzle”,

ensuring uniform water loading and distribution of water over the fill. All pipes and fittings shall be of PVC. The sprinklers shall operate from the residual velocity head at the headers. Due care shall be taken with regard to corrosive effects and maintainability in the design of the water distribution system.

- ix) Drift eliminators of PVC shall be provided for maximum removal of entrained water droplets. The spacers and tie rods used shall be of plastic material.
- x) The fan shall be multi-blade axial flow type, made of aluminium alloy or FRP. The fan assembly shall be statically and dynamically balanced.
- xi) The fan drive shall be from a three phase induction motor **of efficiency class IE3 as per IS 12615**, either direct or through a spiral gear work. The entire drive arrangement shall be designed for a minimum noise and it shall be rigidly supported to the tower structure.
- xii) The motor starter shall be in accordance with para 13.9.
- xiii) To ensure safety of personnel at the time of working on cooling tower a steel ladder shall be provided in such a manner and location as necessary to give safe and complete access to all the parts of the cooling tower requiring inspection or adjustments. The ladder shall be bolted to the tower at the top and grouted in masonry at the bottom end.

7.5 INSTALLATION

The cooling tower shall be installed on M.S. girders fixed in masonry foundations with cement concrete footing. Second class brick work and cement mortar having one part cement & six parts sand shall be used for the masonry work. 12mm sand cement plaster shall be provided over the brickwork.

These may be located at a well-ventilated place either at ground level and contiguous to the plant room, or on the terrace of the building in consultation with the Architect. In case the cooling towers are located on the terrace of the building, the structural loading of the terrace shall be considered. For this respective columns are to be raised by two feet at the terrace. Cooling towers shall be installed in such a way that their load is transferred directly to the columns for which necessary Mild steel-I sections shall be provided by the air-conditioning contractor. The cooling towers shall be rested on Mild Steel-I sections & not on terrace slab. Sufficient free space shall be left all around for efficient operation of the cooling tower.

Cooling tower shall be not less than 75cm above the ground/ floor level unless otherwise stated in the tender specifications. 6mm neoprene pads shall be placed between the tower and the girder for vibration isolation whereas directed by the Engineer-in-charge. Guy-wires of suitable sized shall be used to secure firmly to its base wherever necessary.

7.6 PAINTING

The cooling towers shall be supplied with the manufacturer's standard finish painting.

CHAPTER- 8

CIRCULATING WATER PUMPS

8.1 SCOPE

This chapter covers the general requirements of water circulating pumps for central air-conditioning, central heating, ETAC and cold room applications. This section does not cover either humidification pumps or spray pumps for spray over coils.

8.2 TYPE

The pumps shall be centrifugal type direct driven with a 3 phase, $415 \pm 10\%$ volts, 50 Hz., A.C. motor. The motor for Chilled Water Pumps shall be suitable for use with Variable Frequency Drive. The motor starter for Condenser Water Pump shall be in accordance para 13.9. The motor shall be screen protected drip proof (SPDP) fan cooled or TEFC type. The efficiency class of motors shall be IE 3 class as per IS 12615. The pumps may be either of horizontal split casing (HSC) type with operating speed not exceeding 1500 rpm, or solid casing, mono block type with operating speed not exceeding 3000 rpm as specified in the tender documents. **Efficiency of the pumps at selection should be preferably 70 % or above.**

8.3 RATING

The pumps shall be suitable for continuous operation in the system. The head and discharge requirements shall be as specified in the tender documents. The discharge rating shall not be less than the flow rate requirement of the respective equipments through which the water is pumped. The head shall be suitable for the system and shall take into consideration the pressure drops across the various equipments and components in the water circuit as well as the frictional losses. The pumps offered shall be of high efficiency.

Pump motors greater than or equal to 3.7 kW (5 hp) shall be controlled by variable speed drives.

8.4 MATERIAL AND CONSTRUCTION

- i) The centrifugal pumps shall conform to IS 1620. **The motor for chilled water pumps shall be suitable for use with variable frequency drive. The motor starter for condenser water pump shall be in accordance with para 13.9. The motor shall be screen protected drip proof (SPDP) fan cooled type. The efficiency class of motor shall be IE 3.**
- ii) The pump casing shall be of heavy section close grained cast iron. The casing shall be provided with air release cock, drain plug and shaft seal arrangement as well as flanges for suction and delivery pipe connections as required.
- iii) The impeller shall be of bronze or gunmetal. This shall be shrouded type with machined collars. Wear rings, where fitted to the impeller, shall be of the same material as the impeller. The impeller surface

shall be smooth finished for minimum frictional loss. The impeller shall be secured to the shaft by a key.

- iv) The shaft shall be of stainless steel and shall be accurately machined. The shaft shall be balanced to avoid vibrations at any speed within the operating range of the pump.
- v) The shaft sleeve shall be of bronze or gunmetal. This shall extend over the full length of the stuffing box or seal housing. The sleeve shall be machined all over and ground on the outside.
- vii) The bearings shall be ball or roller type suitable for the duty involved. These shall be grease lubricated and shall be provided with grease nipples/cups. The bearings shall be effectively sealed against leakage of lubricant.
- vii) The shaft seal shall be stuffing box type unless otherwise specified, so as to allow minimum leakage compatible with the operation of the seal. The stuffing box shall be of adequate length and shall be packed with graphite asbestos or any other suitable material for the operating temperature. A drip well shall be provided beneath the seal.
- viii) In the case of HSC pumps, the same shall be directly coupled to the motor shaft through, a flexible coupling protected by a coupling guard. In case of mono block pumps with solid casing, the motor and pumps shall be on a common shaft.
- ix) The pump and motor shall be mounted on a common base plate either of cast iron or fabricated from rolled steel section. The base plate shall have rigid, flat and true surfaces to receive the pump and motor mounting feet.

8.5 ACCESSORIES

Each pump shall be provided with the following accessories: -

- a) Pressure gauges at suction and discharge sides,
- b) Butterfly valves on suction and discharge, and
- c) Reducers, as may be required to match the sizes of the connected pipe work.
- d) Non—return valve at the discharge.

8.6 INSULATION

The thermal insulation of the pump casing for hot/chilled water circulating pumps shall be of the same type and thickness as provided for the connected pipe work and is discussed in Chapter 11.

8.7 INSTALLATION

- i) The pump and motor assembly shall be mounted and arranged for ease of maintenance and to prevent transmission of vibration and noise to the building structure or excess vibration to the pipe work.
- ii) More than one pump and motor assembly shall not be installed on a single base or cement concrete block. The mass of the inertia block shall not be less than the combined mass of the pump and motor assembly. The inertia block shall be vibration isolated from the plant room floor by 25 mm. neoprene or any other equivalent vibration isolation fittings. Where spring mountings are used for vibration isolation, these shall be complete with leveling screws and lock nuts

and shall be placed over a concrete plinth for distribution of the mass of the assembly over the plant room floor. The pump motor sets shall be properly aligned to the satisfaction of the Engineer-in-charge.

8.8 PAINTING

The pumps shall be supplied with the manufacturer's standard finish painting.

8.9 VARIABLE FLOW HYDRONIC SYSTEMS

8.9.1 Variable Fluid Flow in Chilled or Hot Water System

Secondary Chilled or hot-water systems shall be designed for variable fluid flow and shall be capable of reducing pump flow rates to no more than the larger of:

- a) 50% of the design flow rate,
or
the minimum flow required by the equipment manufacturer for proper operation of the chillers,
or
boilers.

8.9.2 Automatic Isolation Valves

Water cooled air-conditioning or heat pump units with a circulation pump motor greater than or equal to 3.7 kW (5 hp) shall have two-way automatic isolation valves on each water cooled air-conditioning or heat pump unit that are interlocked with the compressor to shut off condenser water flow when the compressor is not operating.

CHAPTER – 9

DUCTING

9.1 SCOPE

This chapter covers the general requirements for sheet metal ductwork for air distribution with associated items such as air outlets and inlets, fresh air intake and fire dampers.

9.2 MATERIAL

9.2.1 Ducts

- i) All ducts shall be fabricated either from Galvanised Sheet Steel (GSS) conforming to IS: 277 or aluminium sheets conforming to IS:737. The steel sheets shall be hot dip galvanized with MAT finish with coating of minimum 120 grams per square meter (GSM) of Zinc, GI sheets shall be lead free, eco friendly and RoHS compliant
- ii) The thickness of sheets for fabrication of rectangular ductwork shall be as under. The thickness required corresponding to the longest side of the rectangular section shall be applicable for all the four sides of the ductwork.

Longest side (mm)	Minimum sheet thickness	
	For GSS	For Aluminium
750 mm and below	0.63	0.80
751 mm to 1500 mm	0.80	1.00
1501 mm to 2250 mm	1.00	1.50
2251 mm & above	1.25	1.80

- (iii) Thickness of sheet for Round Ducts

Diameter of duct, mm	Thickness of Sheet, mm	
	GI sheets	Aluminium Sheets
150 to 500	0.63	0.80
501 to 750	0.80	0.80
751 to 1000	0.80	1.00
1001 to 1250	1.00	1.50
1251 and above	1.25	1.80

- iv) All sheet metal connections, partitions and plenums required for flow of air through the filters, fans etc. shall be at least 1.25 mm thick

galvanised steel sheets, incase of G.I. sheet ducting or 1.8 mm thick aluminium sheet, in case of aluminium sheet ducting and shall be stiffened with 25 mm x 25 mm x 3 mm angle iron braces.

- v) Circular ducts, where provided shall be of thickness as specified in IS: 655 as amended upto date.
- vi) Aluminium ducting shall normally be used for clean room applications, hospitals works and wherever high cleanliness standards are functional requirements.

9.2.2 Associated Items

- i) Supply/ return air outlets, F.A. grilles and accessories shall be constructed from extruded aluminium sections.
- ii) Flanges for matching duct sections, stiffening angles (braces) and supporting angles shall be of rolled steel sections, and shall be of the following sizes.

Application	Duct Width	Angle size
Flanges	Upto 1000 mm	35 mm x 35 mm x 3 mm
-do-	1001 mm to 2250 mm	40 mm x 40 mm x 3 mm
-do-	More than 2250 mm	50 mm x 50 mm x 3 mm
Bracings	Upto 1000 mm	25 mm x 25 mm x 3 mm
-do-	More than 1000 mm	40 mm x 40 mm x 3 mm
Support angles	Upto 1000 mm	40 mm x 40 mm x 3 mm
-do-	1001 mm to 2250 mm	40 mm x 40 mm x 3 mm
-do-	More than 2250 mm	Size and type of RS section shall be decided in individual cases

- iii) Hanger rods shall be of mild steel and of at least 10 mm dia for ducts upto 2250 mm size, and 12 mm dia for larger sizes.
- iv) All nuts, bolts and washers shall be zinc plated steel. All rivets shall be galvanised or shall be made of magnesium - aluminium alloy. Self tapping screws shall not be used.

9.3 CONSTRUCTION

9.3.1 Ducts

- i) Ducts shall be fabricated at site or factory fabricated and shall be generally as per IS: 655 "Specifications for metal air ducts", unless otherwise deviated in these General Specifications.
- ii) The interior surfaces of the ducting shall be smooth.
- iii) All the ducts upto 600 mm longest side shall be cross broken between flanges by a single continuous breaking. Ducts of size 600 mm and above shall be cross broken by single continuous breaking between flanges and bracings. Alternatively, beading at 300 mm centres for ducts upto 600 mm longest side, and 300 mm centres for ducts above 600 mm size shall be provided for stiffening.

- iv) As far as possible, long radius elbows and gradual changes in shape shall be used to maintain uniform velocity accompanied by decreased turbulence, lower resistance and minimum noise. The ratio of the size of the duct to the radius of the elbow shall be normally not less than 1:1.5.
- v) Flanged joints shall be used at intervals not exceeding 2500 mm. Flanges shall be welded at corners first and then riveted to the duct.
- vi) Stiffening angles shall be fixed to the sides of the ducts by riveting at 1.25 meters from joints for ducts of size 600 mm to 1500 mm, and 0.6 mm from joints for ducts of size larger than 1500 mm. Bracings for ducts larger than 1500 mm can alternatively be by diagonal angles.
- vii) Plenums for filters shall be complete with suitable access door of size 450 mm x 450 mm.
- viii) All factory fabricated duct shall be supplied in L sections, the length of any piece shall not be more than 1800 mm for duct with longest side of cross section as 600 mm and above and 3000 mm for rest.

9.3.2 Air Outlet and Inlets (Supply and Return)

- i) All air outlets and intakes shall be made of extruded aluminium sections & shall present a neat appearance and shall be rigid with mechanical joints.
- ii) Square and rectangular wall outlets shall have a flanged frame with the outside edges returned or curved 5 to 7 mm and fitted with a suitable flexible gasket between the concealed face of the flanges and the finished wall face. The core of supply air register shall have adjustable front louvers parallel to the longer side to give upto 22.5 degrees vertical deflection and adjustable back louvers parallel to the shorter side to achieve a horizontal spread air pattern to at least 45 degrees. Return air grilles shall have only front louvers. The outer framework of the grilles shall be made of not less than 1.6 mm thick aluminium sheet. The louvers shall be of aerofoil design of extruded aluminium section with minimum thickness of 0.8mm at front and shall be made of 0.8mm thick aluminium sheet. Louvers may be spaced 18 mm apart.
- iii) Square and rectangular ceiling outlets/intakes shall have a flange flush with the ceiling into which it is fitted or shall be of anti smudge type. The outlets shall comprise an outer shell with duct collar and removable diffusing assembly. These shall be suitable for discharge in one or more directions as required. The outer shell shall not be less than 1.6 mm thick extruded section aluminium sheet. The diffuser assembly shall not be less than 0.80 mm thick extruded aluminium section.
- iv) Circular ceiling outlets/intakes shall have either flush or anti smudge outer cone as specified in the tender specifications. Flush outer cones shall have the lower edge of the cone not more than 5 mm below the underside of the finished ceiling into which it is fitted. Anti smudge cones shall have the outer cone profile designed to reduce dirt deposit

on the ceiling adjacent to the air outlet. The metal sheet used for construction of these shall be minimum 1.6 mm thick extruded aluminium sheet.

- v) Linear diffusers shall have a flanged frame with the outside edges returned 3.5 mm and shall have one to four slots as required. The air quantity through each slot shall be adjustable. The metal sheet used for the construction of these shall be minimum 1.6 mm thick extruded aluminium sheet.
- vi) Grilles and diffusers constructed of extruded aluminium sections shall have grille bars set straight, or deflected as required. These shall be assembled by mechanical interlocking of components to prevent distortion. These grilles and diffusers shall have a rear set of adjustable blades, perpendicular to the face blades for deflection purposes.
- vii) All supply air outlets shall be fitted with a volume control device, made of extruded aluminium gate section. The blades of the device shall be mill finish/ block shade pivoted on nylon brushes to avoid rusting & rattling noise, which shall be located immediately behind the outlet and shall be fully adjustable from within the occupied space without removing any access panel. The volume control device for circular outlets shall be opposed blade radial /shutter type dampers, or two or more butterfly dampers in conjunction with equalizing grid. Opposed blade dampers shall be used for square and rectangular ceiling/wall outlets and intakes.
- viii) All the products supplied by contractor should supplement in performance by selection curves of product ratings from the manufacturer.
- ix) Laminar supply air diffusers shall be made of 2mm thick powder coated aluminium sheet duly insulated with 5mm thick closed cell polyethylene foam insulation having factory laminated aluminium foil and joints covered with self adhesive aluminium tape and having holes 2/3 mm dia including frame work.

9.3.3 Fresh Air Intakes

- i) Fresh air intake grilles shall be made of extruded aluminium sections.
- ii) A flanged frame using RS sections shall be provided on front face to conceal the gap between the louvers and the adjoining wall face. Corners of frame shall be welded. The frame shall be made structurally rigid.
- iii) Louvers made from extruded aluminium section shall be in modular panel form for ease of handling. These shall be free from waves and buckles. Vertical blades shall be truly vertical and horizontal blades shall be truly horizontal. Butt joints in blades shall not be accepted.
- iv) Additional intermediate equally spaced supports and stiffeners shall be provided to prevent sagging/ vibrating of the louvers, at not more than 750mm centres where the louver's length is longer than 750mm.

- v) A bird wire screen made of 12 mm mesh in 1.6 mm steel wire held in angle or channel frame shall be fixed to the rear face of the louver frame by screens.

9.4 FIRE DAMPERS

- i) Fire dampers shall be provided in all the supply air ducts and return air ducts (where provided), return air passage in the air-handling unit room and at all floor crossings. Access door will be provided in the duct before each set of fire dampers.
- ii) Fire dampers shall be multi blade louvers type. The blade should remain in the air stream in open position & shall allow maximum free area to reduce pressure drop & noise in the air passage. The blades and frame shall be constructed with minimum 1.6mm thick galvanised sheet & shall be factory fitted in a sleeve made out of 1.6mm galvanised sheet of minimum 400mm long. It shall be complete with locking device, motorised actuator & control panel.
- iii) Fire dampers shall be motorised smoke & fire dampers type. It shall be supplied with spring loaded UL stamped fusible link to close fire damper in the event of rise in duct temperature. Fire damper shall also close on receipt of fire alarm signal to cut off air supply instantaneously. An electric limit switch shall also be operated by the closing of fire damper, which in turn shall switch off power supply to AHU blower motor as well as strip heaters.
- iv) Fire dampers shall be CBRI tested & certified for 90 minutes rating against collapse & flame penetration as per UL 555-1995.(Under writers laboratories)
- v) Fire dampers shall be compatible with the fire detection system of building & shall be capable of operating automatically through an electric motor on receiving signal from fire alarm panel.
- vi) Necessary wiring from fire alarm panel up to AHU electric panel shall be provided by the department & further from AHU electric panel to fire damper shall be provided by air conditioning contractor.

9.5 VARIABLE AIR VOLUME (VAV) BOXES

- i) These shall be of the low velocity variable air volume boxes without re-heat coils, and shall be of open protocol as marketed by a firm specializing in this field. The contractor shall supply and install units to the quantity and locations as specified.
- ii) The unit shall be complete with damper, airflow ring, and solid-state electronic controls to provide accurate room temperature control. The damper shall be aero foil type construction with bearings.
- iii) Boxes shall be supplied with all internal attenuation treatment and acoustical damped casing necessary to achieve the required noise criteria. Casing shall be of 22G GSS minimum fitted with a completely sealed,

easily removable means of access to all internal parts. Access to all boxes must be from the underside only.

- iv) The actuator shall be of 24V AC Bi-directional, direct coupled to the damper shaft. The required transformer to step down of the voltage range from 230V to 24V shall be part of the unit. The power point with an isolator near the VAV will be provided by other agencies.
- v) The unit shall be complete with transformer, access panel and other accessories as per the standard.
- vi) The noise level shall be less than 35dbA.
- vii) Maximum allowable static pressure to the boxes for its satisfactory operation shall not exceed 0.10WG, otherwise fan and motor selections may be affected.
- viii) Boxes shall be able to reset any air flow between 10% and the maximum air quantity that the boxes can handle without changing orifices or other parts. Air quantity limiters will not be accepted.
- ix) A suitable device shall be provided for the field adjustment of minimum airflow. All boxes shall be initially factory set at minimum air quantity of 10% and maximum quantity of 110% of the design requirements.
- x) Under shut-off conditions, all boxes shall not have air leakage more than 2% of the maximum air quantity at 75mm static pressure.
- xi) The VAVs shall be used in standalone mode complete with its own temperature sensor and controller and shall perform the function of maintaining the temperature and airflow.
- xii) Where ever specified, the VAVs shall be BMS compatible to enable to network the VAVs to a Network Control Unit and onto BMS. In this mode all VAV data shall be available at the BMS workstation and it shall be possible to change set points and flow settings from the BMS workstation. All such controllers used for the control of VAV boxes shall be compliant with BACnet/ MODBUS protocol and be freely communicable to third party BACnet/ MODBUS IP controllers.
- xiii) All boxes shall be electrically controlled. The boxes shall be pressure independent.
- xiv) VAV Box shall have provision to support from floor/ wall/ ceiling and in vertical/ horizontal condition.

9.6 ACOUSTIC LINING AND INSULATION

This shall be done as per details given in para 11.8 and 11.9 (Chapter 11).

9.7 FLEXIBLE DUCTING

9.7.1 Application

Flexible Duct is a round, flexible light weight duct and is preliminary used for

- i) Speedy completion of project
- ii) Offers a high degree of flexibility, which allows it to be easily connected to any desired position.
- iii) A quick and economical means of correcting misalignment between system components.
- iv) Allows ducting around obstacles where fabricated and fitted ducts would be difficult and costly to install.

9.7.2 Material

- i) An uninsulated flexible duct shall be made of double lamination of metalized polyester film permanently bonded to a coated spring steel wire helix. Duct shall be in tear & puncture resistant construction.
- ii) For insulated flexible duct where specified, inner core for the same should be made of double lamination of metalized polyester film permanently bonded to a coated spring steel wire helix. Fiberglass insulation of minimum 14 kg/cu.m density, 25 mm thickness shall be wrapped over the inner core & covered with strong outer jacket cum vapour barrier made of fibre glass reinforced metalized polyester film laminate.
- iii) Care must be taken to install all the flexible duct in fully extended position & bends made with adequate radius as per manufacturer recommended practices.

9.8 INSTALLATION OF METALLIC DUCT

9.8.1 Ducting

- i) The fabrication and installation shall be in a workmanlike manner. Duct work shall be rigid and straight without kinks.
- ii) All exposed ducts within the conditioned space shall have slip joints. Flanged joints shall not be used.
- iii) All joints shall be airtight.
- iv) Ducts shall be supported independently from the building structure and adequately, to keep the ducts true to shape. The support spacing shall be not more than 2 m. where ducts cannot be suspended from ceiling, wall brackets or other suitable arrangements, as approved by the Engineer-in-charge shall be adopted. Neoprene or other vibration isolation packing of minimum 6 mm thickness shall be provided between the ducts and the angle iron supports/brackets. Vertical duct work shall be suitably supported at each floor by steel structural members.
- v) Where metal ducts or sleeves terminate in woodwork, tight joints shall be made by means of closely fitting heavy flanged collars. Where ducts pass through brick or masonry openings, wooden frame work shall be provided within the openings and the crossing ducts shall be provided with heavy flanged collars on either side of the wooden frame work, so that duct crossing is made leak-proof.
- vi) Duct connections to the air-handling unit shall be made by inserting a double canvas sleeve 100 mm long. The sleeve shall be securely bonded and bolted to the duct and unit casing.
- vii) Dampers shall be provided in branch duct connections for proper volume control and balancing the air quantities in the system, whether indicated in the drawings or not. Suitable links, levers and quadrants shall be provided for proper operation, control and setting of the

dampers. Every damper shall have an indicating device clearly showing the position of the dampers at all times.

- viii) Where electrical heaters are mounted in the duct, these shall be of low temperature totally enclosed type fitted with radiation fins. A removable panel for access to the heaters shall be provided in the duct. Any hole in the duct for electrical wiring must be provided with suitable bushes to avoid leakage. 6 mm thick asbestos board lining shall be provided all around the inside of the duct for a distance of 30 cms. on either side of the electrical heaters. A manually reset thermostatic safety switch shall be provided near the duct section having heaters. In addition, the heaters must be interlocked with the connected fan motor of the AHU.

9.8.2 Air Outlets and Inlets

- i) The locations of the air outlets and intakes shall be shown in the tender drawings and necessary openings and the wooden framework for fixing the grilles shall be provided by the air conditioning contractor. The location of these outlets/ inlets is subject to change and the approval of the Engineer-in-Charge shall be obtained before finally fixing the grilles/diffusers in position.
- ii) In installing fresh air intakes, no fixing device shall be visible from the face of the frame. Where louvers are to be fixed in masonry or concrete, fixing shall be with either expanding plugs or raw plugs. Where the louvers are to be fixed in steel or wood, non-ferrous screws or bolts shall be used.
- iii) Supply air outlets and return air intakes shall be anodized/ powder coated aluminium to the desired colour to match the surroundings wall/ceiling. The fresh air intakes shall be anodized/ powder coated aluminium as approved by the Engineer-in-Charge. The paint colour shall be approved by the Engineer-in-Charge.
- iv) All damages to the finish of the structure during the installation work shall be made good by the air-conditioning contractor before handing over the installation to the Department.

9.9 BALANCING

Air systems shall be balanced in a manner to minimize throttling losses. The entire air distribution system shall be balanced with the help of an anemometer. The measured air quantities at fan discharge and at the various outlets shall be within ± 5 percent of those specified/quoted. For fans greater than 0.75 KW (1.0 HP), fans must then be adjusted to meet design flow conditions. Branch duct adjustments shall be permanently marked after the air balancing is completed so that these can be restored to their correct position if disturbed at any time.

9.10 MEASUREMENT

- i) Duct measurements (for insulated ducts) shall be taken before application of insulation.

- ii) Duct work shall be measured section wise on the basis of external surface area by multiplying the axial length from flange face to flange face for each section by the corresponding duct perimeter in the centre of that section length.
- iii) Uniformly tapering straight sections shall also be measured as in (ii) above. However, for special pieces like tees, bends etc. area computations for surface areas shall be done as per the shape of such pieces.
- iv) The quoted unit rate for external surfaces of ducts shall include all wastage allowances, flanges, gaskets for joints, vibration isolators, bracings, hangers and supports, inspection chambers/access panels, splitter dampers with quadrants and levers for position indication, turning vanes, straightening vanes, and all other accessories required to complete the duct installation as per the specifications. These accessories shall not be separately measured.
- v) Grilles and diffusers (except linear diffusers) shall be measured by the cross sectional areas, perpendicular to the airflow, and excluding the flanges. Volume control dampers, where provided shall not be separately accounted for.
- vi) Linear diffusers shall be measured by linear measurements only, and not by cross-sectional areas, and shall exclude flanges for mounting of the linear diffusers. The supply air plenum for linear diffusers shall be measured as described above for ducting.
- vii) Fire dampers shall be measured by their cross sectional area perpendicular to the direction of the airflow. Quoted rates shall include the necessary collars and flanges for mounting, inspection pieces with access door, fusible link/solenoid with wiring, but excluding the fire detectors, etc.

CHAPTER- 10

WATER PLUMBING WORK

10.1 SCOPE

This chapter covers the requirements of plumbing work in chilled water, hot water, water in condenser circuit and drains, to be executed as part of heating, ventilating and air conditioning.

10.2 PLUMBING DESIGN

Pipe sizes shown in tender documents are purely for contractor's guidance. The contractor shall be responsible for selection of sizes as per detailed engineering to be done by him. Plumbing design to be done by the Air-conditioning contractor shall conform to the following: -

- i) Water velocity in pipes shall not exceed 2.5 m/sec.
- ii) Butterfly/ Ball valves shall be provided at
 - a) suction and delivery sides of pumps.
 - b) inlet and outlet of each condenser, chiller, cooling tower, hot water generator.
 - c) all drain connections from equipments.
 - d) Inlet & outlet of every heat exchanger coil, namely for AHU's, FCUs's, convector etc.
- iii) Non return valve shall be provided at the delivery of each pump. This shall be of swing type.
- iv) Balancing valve shall be provided at the outlet side of chiller, condenser, heating and cooling coils to regulate the maximum flow rate upto value preset as desired.
- v) Balancing valves shall be provided, where specified, for AHU's to regulate the maximum flow rate upto a value preset as desired. A mercury manometer shall be supplied with every 10 nos. or part thereof of balancing valves, whether or not specifically indicated in the tender specifications.
- vi) Air valves shall be provided at all high points in the piping system for venting with a size of 25 mm for pipes upto 100 mm and 40 mm for larger pipes.
- vii) Plumbing drawings showing the sizes of valves, layout and other details shall be prepared and shall be got approved from the Engineer-in-Charge before the execution of the plumbing work.

10.3. PIPE MATERIALS

Pipes shall be of the following materials.

- (i) Mild steel medium class (Black steel) tube conforming to IS: 1239 for sizes upto 150 mm.
- (ii) Welded black steel pipe, class 2, conforming to IS: 3589, for sizes greater than 150 mm. These pipes shall be factory rolled & fabricated from minimum 6mm thick M.S. Sheet for pipes upto 350mm dia & from minimum 7mm thick M.S. sheet for pipes of 400mm dia & above.

10.4 PIPE JOINTS

Seismic considerations shall be taken into account while planning joint details. Joints in black steel pipes shall be of any of the following types.

- (i) Screwed joints and union joints screwed to pipes, upto 25 mm size.
- (ii) Butt welded joints for pipe sizes above 25mm. Electric welding shall be used for sizes 100mm and above.
- (iii) Flanges joints with flanges as per IS: 6392 for all sizes. Flanges may be steel welded neck type or slip on type welded to pipe, or alternatively screwed type. The item of flanges shall be measured and paid separately.
- (iv) Flexible coupling V groove joints.
- (v) Flexible connections shall be provided at the pumps, and other machine where requires as per following specifications-

- a) The Flexible connections shall be flanged type expansion joint. Flanges shall be non-compressible and mechanically strong type and the Neoprene rubber shall be provided in between the flange ends.
- b) The connections shall work for a temperature range of minus 10°C to 70°C.
- c) The length and working pressure of bellows shall be as follows:

Nominal Bore (mm)	Length (mm)	Pressure (Bar)
20-25	125	15
32-200	150	15
250-350	200	10

- d) Connections shall be provided with control rods to control the excessive elongation or compression of piping systems.
- e) these shall be capable to withstand torsional movement upto 3° without damage.

10.5 PRE INSULATED CHILLED WATER PIPES

- i) The pipe shall be MS ERW as specified in the Piping Section.
- ii) The pipe insulation shall be polyurethane foam with minimum density of 36 kg/cu m, 90% minimum closed cell content, minimum compressive strength of 2.7kg/cm² and initial thermal conductivity of 0.02W/mK. The insulation shall completely fill the annular space between the service pipe and jacket and shall be bonded to both, the service pipe & jacket.
- iii) The cladding shall be spirally wounded of G.I. or Aluminium as specified in tender documents for pipes installed on surface.

- iv) For pipes installed on surface The insulation (PUF) shall be provided to the thickness with thickness of cladding as below:

S.No.	Dia. Of MS Pipe	Minimum Thickness of PUF in (mm)	Minimum Thickness of G.I. Cladding	Minimum Thickness of Al. Cladding
1.	20 mm	33	0.457mm (26g)	0.559mm (24g)
2.	25 mm	32	0.457mm (26g)	0.559mm (24g)
3.	32 mm	33	0.457mm (26g)	0.559mm (24g)
4.	40 mm	30	0.457mm (26g)	0.559mm (24g)
5.	50 mm	31	0.457mm (26g)	0.559mm (24g)
6.	65 mm	36	0.457mm (26g)	0.559mm (24g)
7.	80 mm	42	0.457mm (26g)	0.559mm (24g)
8.	100 mm	42	0.457mm (26g)	0.559mm (24g)
9.	125mm	41	0.457mm (26g)	0.559mm (24g)
10.	150 mm	41	0.457mm (26g)	0.559mm (24g)
11.	200 mm	52	0.457mm (26g)	0.559mm (24g)
12.	250 mm	62	0.457mm (26g)	0.559mm (24g)
13.	300 mm	51	0.457mm (26g)	0.559mm (24g)
14.	350 mm	46	0.457mm (26g)	0.559mm (24g)
15.	400 mm	46	0.457mm (26g)	0.559mm (24g)
16.	450mm	45	0.457mm (26g)	0.559mm (24g)
17.	500mm	57	0.559mm (24g)	0.711mm (22g)
18.	550mm	57	0.559mm (24g)	0.711mm (22g)
19.	600mm	57	0.559mm (24g)	0.711mm (22g)
20.	650mm	56	0.559mm (24g)	0.711mm (22g)
21.	700mm	56	0.559mm (24g)	0.711mm (22g)
22.	750mm	55	0.559mm (24g)	0.711mm (22g)
23.	800mm	55	0.559mm (24g)	0.711mm (22g)

- v) Underground systems shall be buried in a trench of not less than 600 mm deeper than the top of the pipe & not less than 450mm wider than the combined OD of all piping systems. A minimum thickness of 600mm of compacted backfill over the top of the pipe is desirable.
- vi) Trench bottom shall have a minimum of 150mm of sand, pea gravel or specified backfill material, consolidated to suit operating weight & to act as a cushion for the piping.
- vii) For pipes buried in ground outer protective insulation jacket shall be seamless, extruded, black, UV resistant, high-density polyethylene (HDPE).
- viii) For leak identification purpose 2 wire diagnostic wiring shall also be provided.
- ix) Fitting can be fabricated at site over the carrier pipe and correct quantity of PUF shall be poured manually.
- x) Field joints insulation shall consist of **PUF** poured manually in a site-fabricated GI cladding fixed around the joint
- xi) For pipes buried in ground minimum thickness of the **HDPE** jacket and PUF shall be as follows:

S.No.	MS Pipe dia. (mm)	PUF Thickness (mm)	Thickness of HDPE Cladding (mm)
1.	20 mm	29	2.5

2.	25 mm	36	2.5
3.	32 mm	31	2.5
4.	40 mm	36	2.5
5.	50 mm	37	3.0
6.	65 mm	39	3.0
7.	80 mm	43	3.0
8.	100 mm	40	3.2
9.	125mm	39	3.5
10.	150 mm	53	4.4
11.	200 mm	63	5.0
12.	250 mm	57	6.3
13.	300 mm	58	7.0
14.	350 mm	64	7.8
15.	400 mm	68	8.8
16.	450mm	77	9.8
17.	500mm	50	11.1
18.	550mm	65	11.1
19.	600mm	83	12.5
20.	650mm	58	12.5
21.	700mm	82	13.0
22.	750mm	104	15.0
23	800mm	79	15.0

10.6 VALVES

- i) The material of butter fly valves shall be as under:
 Body- Cast iron
 Disc- Cast Bronze or Stainless Steel
 Seat- Either integral or Nitrile rubber
 O-ring- Nitrile/ Silicon
- ii) Balancing valve shall be of cast iron flanged construction with EPDM/ SG iron with epoxy coated disc with built in pressure drop measuring facility (pressure test cocks) to compute flow rate across the valve. The test cocks shall be long enough to protrude out of pipe insulation.
- iii) Non return valves shall be of gun metal construction upto 65 mm, the metal conforming to class 2 of IS: 778. For 75 mm and above, the valve shall be of bronze or gun metal, body being of cast iron. While screwed or flanged ends may be provided upto 65 mm, flanged ends shall be provided for larger sizes.
- iv) Air valves shall be of gunmetal body.

10.7 STRAINERS

- (i) Strainers shall be of 'Y' type or pot type as specified.
- (ii) 'Y' strainers shall be provided on the inlet side of each air-handling unit and pump in chilled water and condenser water circuit.
- (iii) Pot strainers, where specified, shall be provided in return water headers, for chilled water and condenser water if enough floor area is available in the refrigeration plant room, as an alternate to individual Y type strainers with pumps.

- (iv) The strainers shall be designed to the test pressure specified for the gate valves.
- (v) Filtration area of Y-strainer shall be minimum four times the connecting pipe size.
- (vi) Strainers shall have a removable bronze/ stainless steel minimum 1mm thick screen with 3 mm perforations and permanent magnet.
- (vii) Strainers shall be provided with flanges or threaded sockets as required. They shall be designed so as to enable blowing out accumulated dirt and facilitate removal and replacement of screen without disconnection of the main pipe.
- (viii) Strainers shall be provided with equal size isolating gate valves on either side so that the strainers may be cleaned without draining the system.

- (ix) Pot strainer shall be fabricated out of MS sheet and the sizes shall be as under: -

Pipe sizes (mm)	Pot dia (mm)	Pot Height (mm)	Basket dia (mm)	Basket Height (mm)
50	300	400	200	240
80	350	450	250	250
100	450	500	300	280
125	500	600	330	340
150	540	700	360	390
200	610	815	400	470
250	800	955	550	510
300	1000	1105	750	580
350	1190	1300	895	678
400	1350	1500	1020	785
450	1518	1700	1060	890
500	1690	1800	1100	900

10.8 INSTRUMENTS

- i) Pressure gauge of appropriate range and 150 mm. dial size shall be provided at the following locations.
 - a) Supply and return of all heat exchange equipments.
 - b) Suction and discharge of all pump sets.

The pressure gauge shall be duly calibrated before installation and shall be complete with shut off cocks.
- ii) Direct reading industrial type thermometer of appropriate range shall be provided at the inlet and outlet of all heat exchange equipments. The thermometers shall be installed in separate wells.
- iii) Appropriate number of additional sockets shall be provided for the installation of pressure & temperature transducers for BMS.

10.9 EXPANSION TANKS

- i) Expansion tanks for chilled water and hot water shall be of M.S. construction and of adequate capacity, to contain 200% of the maximum expansion likely to take place in the system. The tank shall be insulated and be complete with float valve, gauge glass, drain, overflow and make up connections, with gate valves and vent piping wherever required.
- ii) The piping shall be enlarged at the connection to the expansion tank to permit entrained air to separate and to be vented through the tank. The expansion tank should be located at the pump suction side at the highest point of the system.
- iii) Valves, strainers and traps must be omitted from the expansion line since these may be accidentally turned off or become plugged.
- iv) Pressurized expansion tank with air separator, can be used where the conventional type expansion tank is not feasible to be provided.

10.10 INSTALLATION

- i) The installation work shall be carried out in accordance with the detailed drawings prepared by the Air-conditioning Contractor and approved by the Engineer-in-charge.
- ii) Air-conditioning contractor shall utilize the structural provisions for Air-conditioning services wherever provided by the Department in the building and make his own arrangements for additional changes.
- iii) Expansion loops or joints shall be provided to take care of expansion or contraction of pipes due to temperature changes.
- iv) Tee-off connections shall be through equal or reducing tees, otherwise ferrules welded to the main pipe shall be used. Drilling and tapping of the walls of the main pipe shall not be resorted to.
- v) Wherever reducers are to be made in horizontal runs, eccentric reducers shall be used if the piping is to drain freely, in other locations, concentric reducers may be used.
- vi) Open ends of piping shall be blocked as soon as the pipe is installed to avoid entrance of foreign matter.
- vii) All pipes using screwed fittings shall be accurately cut to the required size and threaded in accordance with IS: 554 and burs removed before laying.
- viii) Piping installation shall be supported on or suspended from structure adequately. The Air-conditioning contractor shall design all brackets, saddles, clamps, hangers etc. and shall be responsible for their structure integrity.

- ix) Pipe supports, preferably floor mounted shall be of steel, adjustable for height and prime-coated with zinc chromate paint and finish-coated gray. Spacing of pipe supports shall not be more than that specified below: -

Nominal Pipe size (mm)	Spacing (Metres)
12 and 15	1.25
20 and 25	2.00
32, 40, 50 and 65	2.50
80, 100 and 125	2.50
150 and above	3.00

Extra supports shall be provided at the bends and at heavy fittings like valves to avoid undue stress on the pipes. Pipe hangers shall be fixed on walls and ceiling by means of metallic or rawl plugs or approved shear fasteners.

- x) Insulated piping shall be supported in such a manner as not to put undue pressure on the insulation.
- xi) Anti vibration pads, springs or liners of resilient and non-deteriorating, material shall be provided at each support, so as to prevent transmission of vibration through the supports.
- xii) Pipe sleeves of diameter larger than the pipe by least 50 mm shall be provided wherever pipes pass through walls and the annular spaces shall be filled with felt and finished with retaining rings.
- xiii) Vertical risers shall be parallel to walls and column lines and shall be straight and plumb. Risers passing from floor to floor shall be supported at each floor by clamps or collars attached to pipe with a 12 mm thick rubber pad or any other resilient material as approved by the Engineer-in-charge.
- xiv) The space in the floor cut outs around the pipe work (after insulation work where applicable) shall be closed using cement concrete (1:2:4 mix) or steel sheet, from the fire safety considerations, taking care to see that a small annular space is left around the pipes to prevent transmission of vibration to the structure.
- xv) Riser shall have suitable supports at the lowest point.
- xvi) Where pipes are to be buried under ground, the top of the pipes shall be not less than 75 cms. from the ground level. Where this is not practicable, permission of the Engineer-in-charge shall be obtained for burying the pipes at lesser depth. The pipes shall be surrounded on all sides by sand cushion of not less than 15 cms. After the pipes have been laid and top sand cushion provided, the trench shall be refilled with the excavated soil and any extra soil shall be removed from the site of work by the Air conditioning contractors.
- xvii) All pipes and their steel supports shall be thoroughly cleaned and given one primer coat of Zinc chromate before being installed.
- xviii) After all the water piping has been installed, pressure tested in accordance with clause 10.10, all exposed piping in the plant room shall be given two finish coats of paint, approved by the Engineer-in-

Charge. Similar painting work shall be done over insulated pipe work, valves etc. The direction of flow of fluid in the pipes shall be indicated with identifying arrows.

- xix) 3 mm gasket shall be used for flanged joints.
- xx) Cut-outs in floor slabs shall be sealed with cement concrete or steel plate after the plumbing work is done, from the fire safety point of view.

10.11 PRESSURE TESTING

- (i) All piping shall be tested to hydrostatic test pressure of at least one and a half times the maximum operating pressure, but not less than 10 kg./sq.cm. for a period not less than 24 hours. All leaks and defects in joints revealed during the testing shall be rectified to the satisfaction of the Engineer-in-Charge.
- (ii) Piping repaired subsequent to the above pressure test shall be re-tested in the same manner.
- (iii) System may be tested in sections and such sections shall be securely capped.
- (iv) It shall be made sure that proper noiseless circulation is achieved through all the coils and other heat exchange equipments in the system. If proper circulation is not achieved due to air-bound connections, the contractor shall rectify the defective connections. He shall bear all the expenses for carrying out the above rectification, including the tearing up and refinishing of floors, walls, etc. as required.
- (v) Insulation shall be applied to piping only after the completion of the pressure testing to the satisfaction of the Engineer-in-charge.
- (vi) Pressure gauges may be capped off during pressure testing of the installation.
- (vii) The contractor shall provide all materials, tools, equipments, instruments, services and labour required to perform the tests and to remove water resulting from cleaning after testing.

10.12 BALANCING

- i) After completion of the installation, all water system shall be adjusted and balanced to first minimize throttling losses; then the pump impeller shall be trimmed or pump speed shall be adjusted to meet design flow conditions.
Exceptions to above:
 - a) Where Variable frequency Drives are used as starter & capacity control.
 - b) Impellers need not to be trimmed nor pump speed adjusted for pumps with pump motors of 7.5 kW (10 hp) or less,
 - c) Impellers need not to be trimmed when throttling results in no greater than 5% of the nameplate horsepower draw, or 2.2 kW (3hp), whichever is greater.
- ii) Automatic control valves (Pressure Independent Balancing cum Control Valve) and three way diverting valves shall be set for full flow condition during balancing procedure. Water circuit shall be adjusted by balancing cocks provided for balancing. These shall be permanently

marked after the balancing is completed so that they can be restored to their correct positions, if disturbed.

10.13 MEASUREMENT

Measurements of plumbing work shall be on following basis: -

- a) Piping shall be measured along the centre line of installed pipes including all pipe fittings and accessories but excluding valves and other items for which quantities are specifically indicated in the schedule of work. No separate payment shall be made for fittings and accessories.
- b) The rates for piping work shall include all wastage allowances, pipe supports, hangers, nuts and check nuts, vibration isolators, suspension where specified or required, and any other item required to complete the piping installation. None of these items will be separately measured nor paid for.
- c) Piping measurement shall be taken before application of the insulation in the case of insulated pipe work.

10.14 INSULATION

The insulation of pipes carrying hot or chilled water shall be carried out as per Chapter 11.

CHAPTER – 11

INSULATION WORK

11.1 SCOPE

This chapter covers the requirements of thermal insulation for chilled water / hot water piping, pumps and tanks, duct work ,and acoustic lining in duct work and weather maker rooms. This does not cover exposed roof insulation and under deck insulation work.

11.2 MATERIAL-TYPES

The insulation material to be used for various applications shall be any of the following, as required:

i) For insulation of water piping, pumps and tanks: -

- a) Expanded polystyrene (T.F.Quality)
- b) Resin bonded glass wool
- c) Polyvinyl Nitrile (Closed cell rubber foam)
- d) XLPE (Closed cell cross linked polyolefin foam)

Expanded polystyrene (T.F.Quality) shall be used for pipe insulation like inside the A.C. plant room, exposed to outside or burried in ground. In the case of expanded polystyrene (TF quality), Resin bonded glass wool the pipe insulation should be in rigid sections in two halves and preformed to fit snugly on to pipes (upto pipe sizes for which the preformed sections are manufactured by the manufacturer of insulation). For higher pipe sizes insulation slabs shall be used.

Resin bonded glass wool is to be used for piping inside the building due to its fire retardant properties, for considerations of fire safety. Polyvinyl Nitrile (Closed cell rubber foam) available in tube shapes for sliding on to the small dia. pipes can be used if successfully tested for fire retardant properties.

However, all shall need to be covered with vapour barrier and cladding with aluminium sheet.

ii) For Insulation of duct work: -

- (a) Resin bonded glass wool.
- (b) Polyvinyl Nitrile (Closed cell rubber foam)

iii) For acoustic lining of duct work and AHU rooms: -

- (a) Resin bonded glass wool.
- (b) Resin bonded mineral wool.

iv) For suction line, Chilled water pipe and Chiller insulation: -

- (a) Expanded Polysterene (T.F.Quality)
- (b) Polyvinyl Nitrile (Closed cell rubber foam)

- (v) For double skin AHUs:
 (a) Polyurethane foam (PUF insulation)

11.3 MATERIAL SPECIFICATIONS

The insulation material shall satisfy the following requirements: -

- i) For thermal application on pipes.

Material	Minimum Density (Kg/cu.m)	Maximum Thermal conductivity (K.cal/ hr. degree C/m at 10 Deg C mean temp.)
Resin bonded glass wool	32	0.031
Expanded polystyrene (TF)	20	0.035
Polyvinyl Nitrile foam	55	0.034

- ii) For thermal insulation of ducts:

<u>Material</u>	<u>Minimum Density(Kg / cu.m)</u>
Resin bonded glass wool	24
Polyvinyl Nitrile foam	40

Fibre Glass Insulation used for duct insulation shall be factory faced with aluminium foil on one side reinforced with kraft paper & fused to the insulation material.

Polyvinyl Nitrile foam Insulation used for duct insulation shall be factory faced with aluminium foil on one side.

- iii) For acoustic lining:

Application	Thickness	Material	Minimum Density (Kg./Cu.M)
Duct	25 mm	Resin bonded glass wool	32
AHU room	50 mm	Resin bonded glass wool/ Mineral wool	32/ 48

- iv) The specification for resin bonded glass wool insulation & resin bonded mineral wool insulation shall conform to IS 8183 as amended upto date. The specification for expanded polystyrene shall conform to IS-4671 as amended upto date.
- v) Expansion tank Insulation
 Expanded polystyrene insulation of density not less than 20kg per cu.m. shall be used.

11.4 INSULATION THICKNESS

The thickness of insulation shall be as indicated below unless specified otherwise in the tender specifications.

i) For pipe insulation (for chilled water as well as hot water application)

Pipe Size (mm)	Glass fibre /Exp. Polystyrene (mm)
150 & below	50
Above 150	75

ii) For Duct insulation

Application	Fibre glass (mm)
Thermal for AC area	12.5
Thermal for Non AC area	25
Acoustic	25

iii) For room acoustic lining

Resin bonded glass wool	50 mm
Resin bonded mineral wool	50 mm

iv) For pumps :

Expanded polystyrene TF quality	50 mm
---------------------------------	-------

v) Chiller Insulation
Thickness of polyvinyl rubber insulation used for chiller insulation shall not be less than 19mm.

vi) Expansion tank
Thickness of expanded polystyrene (TF quality) insulation used shall not be less than 50mm.

11.5 APPLICATION OF INSULATION ON PIPES (including suction line insulation)

(i) The surface to be insulated shall be first cleaned and a coat of zinc chromate primer shall be given. The insulation shall be fixed tightly to the surface with cold setting adhesive CPRX compound. All joints shall be staggered and sealed. The second layer of insulation wherever required shall be similarly applied over the first layer.

(ii) Pipes shall be preferably pre insulated at factory, meeting the requirement or the insulation shall be finished at site as under:

(a) For pipes laid inside the building, the insulation over the pipe work shall be finished with 0.63 mm thick aluminium sheet cladding over a vapour barrier of 120 gm/ sq.m. polythene sheet with 50 mm overlap and tied down with lacing wire and complete with type 3, grade-I roofing felt strip (as per IS 1322 as amended upto date) at the joints..

(b) For pipes outside the building laid above ground the finishing over the pipe insulation shall be finished with 0.63 mm G S sheet cladding over a vapour barrier of 120 gm/sq.m polythene sheet with 50mm overlap

and tied down with lacing wire and complete with type 3 grade I roofing felt strip applied by means of cold setting CPRX compound..

- (c) For pipes outside the building laid under ground the insulation shall be covered with 500 gauge polythene faced hessian, (the polythene facing outwards), with 50 mm overlap. All joints shall be sealed with bitumen. A layer of 0.50 mm x 20 mm G.I. wire mesh netting shall be provided over it butting all joints and it shall be laced down with GI wire, sand cement plaster (1:4) 20 mm. thick shall be provided in 2 layers of each 10mm and shall be water proofed by applying hot bitumen & fixing tar felt over the plaster. It shall be finally finished with a coat of hot bitumen.) In case of factory pre insulated pipes, buried underground, a water leakage sensing wire shall also be provided, to detect the location of water leakage at later date.
- (d) In case of factory pre insulated pipes, all joints shall be properly insulated at site as per recommendation of manufacturer
- (iii) All valves, fittings, strainers etc. shall be insulated to the same thickness and in the same manner as for the respective piping, taking care to allow operation of valves without damaging the insulation.

11.6 APPLICATION OF INSULATION ON PUMPS

Expanded polystyrene (TF quality) 50mm thickness shall be sandwiched between two aluminium sheets of 0.5mm thickness and properly clamped to pump in two semicircular sections.

11.7 APPLICATION OF INSULATION ON EXPANSION TANK

Insulation of expansion tank shall be expanded polysterene (T.F.Quality) of thickness not less than 50mm. It shall be applied as under

- i) Surface shall be thoroughly cleaned with wire brush and rendered free from all dust & grease.
- ii) The two layers of hot bitumen shall be applied.
- iii) The insulation slabs will then be fixed in one layer and joints shall be sealed with hot bitumen.
- iv) The insulation slab then shall be covered with 0.63 mm x 19mm G.I. wire mesh netting which shall be fixed to insulation with brass / G.I. nails.
- v) The insulation shall then finally be finished with aluminium cladding of thickness not less than 0.5mm.

11.8 APPLICATION OF INSULATION (THERMAL) ON DUCT

- i) The surface of duct on which the external thermal insulation is to be provided shall be thoroughly cleaned with wire brush and rendered free from all dust and grease.
- ii) Two coats of cold compound adhesive (CPRX compound) shall be applied over the duct. (Any other adhesive recommended by the manufacturers may also be used with the approval of the Engineer-in-charge).

11.9 APPLICATION OF DUCT LINING (ACOUSTIC INSULATION)

Where specified in the tender specifications, ducts shall be lined internally with acoustic insulation as detailed below:

- i) The Inside surface of duct on which the acoustic lining is to be provided shall be thoroughly cleaned with wire brush and rendered free from all dust and grease.
- ii) Then 25 x 25 sq.mm section of minimum 1.25 mm thick G.I. sheet shall be fixed on both ends of the duct piece.
- iii) The insulation slabs shall then be fixed between these section of ducts using CPRX adhesive compound and stickpins.
- iv) The insulation shall then be covered with Reinforced plastic/ fibre glass tissue **with proper overlap**, sealing all joints so that no fibre is visible.
- v) The insulation shall finally be covered with minimum 0.5 mm thick perforated aluminium sheet having perforations between 20-40%.

11.10 APPLICATION OF ACOUSTIC LINING IN AHU ROOMS

- i) The wall/ roof surface should be thoroughly cleaned with wire brush.
- ii) A 610x610 mm frame work of 25mm x50mm x50mm x50mm x25mm shape channel made of 0.6mm thick G.S.S. shall be fixed to walls leaving 610mm from floor by means of raw plugs in walls and dash fasteners in ceiling. Similar frame work shall also be fixed on ceiling by means of dash fasteners.
- iii) Resin bonded glass wool/ mineral wool as specified cut to size will be friction fitted in the frame work and covered with tissue paper.
- iv) Aluminium perforated sheet having perforation between 20-40% of thickness not less than 0.8mm shall be fixed over the entire surface neatly without causing sag/ depression in between and held with screws. Sheet joints should overlap minimum 10mm.
- v) Aluminium beading of 25mm wide and thickness not less than 1.00 mm shall be fixed on all horizontal/ vertical joints by means of screws.

11.11 MEASUREMENT OF INSULATION

- a) Pipe insulation shall be measured in units of length along the centre line of the insulated pipe. The linear measurements shall be taken before the application of the insulation. For piping measurements, all valves, orifice plates and strainers shall be considered strictly by linear measurement along the centre line of the pipes, and no special rate shall be applicable for insulation of any accessories, fixtures or fittings whatsoever.

- b) Duct insulation and acoustic lining shall be measured on the basis of surface area along the outer surface (ref IS14164 of 2008) of insulation thickness. Thus the surface area of externally thermal insulated or acoustically lined duct shall be based on the perimeter at the centre of thickness of insulation, multiplied by the centre-line length of ducting including tapered pieces, bends, tees, branches etc. as measured for bare ducting. In the case of tapering pieces, their average perimeter shall be considered.

CHAPTER-12

CONTROLS

12.1 SCOPE

This chapter covers the requirements of equipment safety controls, refrigerant flow controls, system controls, and variable speed drive (VSD). For chilling units all the controls shall be microprocessor based.

12.2 EQUIPMENT SAFETY CONTROLS

12.2.1 Compressor:

12.2.1.1 Compressor shall be provided with the following safety controls: -

- i) High discharge pressure (HP) safety (cut out) to stop the compressor automatically, in case discharge pressure exceeds a pre-set safe value. This safety shall operate when discharge head pressure exceeds the set point. Only manual resetting shall be provided for this safety.
- ii) Low suction pressure (LP) safety (cut-out) to stop the compressor automatically, in case suction pressure falls below a pre-set value. This safety shall operate when the suction pressure falls below the set point. Automatic resetting shall be provided for this safety, with adjustable cut-in and cut-out pressures. This safety shall be used for pumping down the system for shutting off the refrigeration plant.
- iii) Oil pressure (O.P) safety (cut-outs) to stop the compressor, in case lubricating oil pressure falls below a safe set value. A time delay mechanism shall also be provided, so as to permit running of the compressor upto a maximum period of 90 seconds, with the oil pressure differential below the set value and allow it to continue normal operation if the pressure differential builds up to the set value within that time, or otherwise shut-down the compressor. Only manual resetting shall be provided for this safety.
- iv) High bearing oil temperature cut-out (for centrifugal compressor only). This shall be provided with a manual reset only.
- v) High lubricating oil temperature cut-out (for centrifugal compressor only). This shall be provided with a manual reset only.
- vi) Time delay mechanism on the starting gear to limit short cycling regardless of mal-functioning of controls.

The cut-outs (i) to (v) mentioned above shall operate when the respective controlled variable crosses the set point to trip the compressor. Audio visual alarm shall be provided to indicate such operations. A manual reset shall be provided for them.

12.2.1.2 Safeties mentioned above shall operate when the respective controlled variable crosses the set point to trip the compressor.

12.2.1.3 Audio visual alarm shall also be provided to indicate such operations.

12.2.2 Condenser

The safety control for a condenser shall comprise a safety pressure relief valve on the shell. This shall operate to relieve the pressure at the set point without prior leakage. For small condensers, a fusible plug may be provided to melt at a predetermined temperature.

12.2.3 Chiller

- i) An antifreeze shall be provided with water chiller, set at a few degrees above the freezing point. This shall operate, when the temperature of water in the chiller falls below the set point to trip the compressor motor. The reset provided for the safety shall be manual.
- ii) Flooded type of chiller in addition, shall be provided with safety pressure relief valve.

12.2.4 Refrigeration Plant

- i) In addition to the safety controls as above for the individual components of a refrigeration plant, the following safety controls shall also be provided for the plant.
 - a) Compressor motor over current cut-out.
 - b) Condenser water flow switch.
 - c) Chilled water flow switch.
 - d) Condenser air flow switch in the condenser fan discharge (in case of air-cooled condensers).
 - e) Air flow switch in the evaporator fan discharge in case of direct expansion coils
- ii) The above controls, on operation, shall trip the compressor motor, and these shall be provided with manual reset arrangement.
- iii) The compressor motor shall also be interlocked electrically with,
 - a) Condenser water pump in case of water cooled condenser, and condenser fan with air cooled condensers,
 - (b) Chilled water pumps in case of chilled water system and evaporator fan in case of direct expansion system, and
 - c) Antifreeze thermostat in case of chillers.
- iv) Indicating lamps shall also be provided on the control panel for indicating operation of the safeties and interlocks.

12.3 REFRIGERANT FLOW CONTROLS

A refrigeration plant shall be provided with controls, necessary for starting, stopping and modulating the flow of refrigerant in the plant so as to satisfy the load requirements. These comprise solenoid valve, thermostatic/ Electronic type expansion valve, float valve, compressor capacity controls etc. and other special controls if specified in a particular work.

12.3.1 Solenoid Valve

- a) For reciprocating and screw type compressors liquid line solenoid valve shall be provided in the liquid line of the system, ahead of the expansion valve, to allow or to stop the flow of liquid refrigerant to an evaporator, or a section of sectionalized evaporator. This shall be operated by snap-acting thermostat and it shall also be provided with a test switch to enable manual energizing.
- b) Discharge gas valves shall be provided in the following applications as required: -
 - i) Hot gas defrosting: Normally this solenoid valve shall remain closed, but it shall open up to feed the evaporator with hot gas for defrosting when required, especially in cold storage applications.
 - ii) Compressor capacity control for reciprocating compressor and for cylinder unloading during starting.
- c) Solenoid valves shall be direct acting in smaller sizes and pilot operated for larger sizes, as required. The size of the valves shall be determined by the desired flow rate of refrigerant through them and the pressure drop across the same (and not by the size of the refrigerant line).

12.3.2 Thermostatic / Electronic type Expansion Valve

Thermostatic/ Electronic type expansion valve shall be provided in DX type refrigeration plant to modulate the flow rate of liquid refrigerant entering the evaporator in response to the extent of superheat of refrigerant gas leaving the evaporator, so that only a metered flow is ensured matching the load.

The number of expansion valve shall be such that the specified accuracy of temperature control of the system can be achieved and that no valve is expected to operate below 35% of its rated capacity. The sizes shall be selected suitably so as to avoid hunting. Adjustable super heat control and external equaliser port shall be provided for each valve. Each expansion valve shall be easily removable for cleaning and adjusting.

12.3.3 Float Valve

Float valve shall be provided in refrigeration plant with flooded type chiller for maintaining the liquid level in chiller under all conditions of load at a rate commensurate with the rate of vaporisation. This can be provided either on low pressure side or on high pressure side. When provided as low side float valve, this shall be located as a part of the chiller or accumulator.

12.3.4 Compressor Capacity Control

The capacity control arrangement shall be in accordance with 5.2.7 for reciprocating type compressor, and 5.3.7 for centrifugal type compressor & 5.4.8 for screw type compressor.

12.4 SYSTEM CONTROLS

- i) The requirements for maintaining the inside design conditions as specified in the tender specifications for the work shall be met by appropriate system controls and control elements. The system shall satisfy the requirements of both full load and partial load conditions. Details of complete control elements shall be indicated by the tenderer in the tender.
- ii) For cooling applications in plants other than package type AC (PTAC) units, control shall be effected by 3 way diverting valve in chilled water coil. For heating using hot water coils, flow control through them shall also be achieved by using 3 way valves.

In the case of PTAC type units, the control of the units is affected through snap acting room thermostat.
- iii) The size of 3 way diverting valves shall be selected so as to match the coil wherein the flow is to be regulated. The make and size shall be indicated in the Technical particulars in the tender.
- iv) Operation of the modulating motor of 3 way diverting valve shall be controlled by proportional type thermostat.
- v) One snap acting humidistat shall be provided for each humidifier.
- vi) Where strip heaters are specified, maximum size of each heater bank shall not exceed 9 KW, distributed in three phases of 3 KW per phase.
- vii) Every bank of strip heaters shall be controlled by a snap acting thermostat in case of temperature control requirement and by a snap acting humidistat for reheat control to maintain the specified RH condition.
- viii) Where more than one bank of heaters is required to be provided for one AHU, thermostat shall be provided in each bank shall suitable for operation in stages.
- ix) A safety thermostat (safety stat) shall be provided as high limit safety for each bank of heaters.
- x) The heater banks intended for reheating during monsoon shall form part of heaters required for winter heating (where winter heating is specified). Necessary change-over switch shall be provided as part of the system wiring to change their control by thermostats or humidistat as required.

12.5 OPERATIONAL CONTROLS AND INTERLOCKS

- i) The operation of refrigeration plant shall be either manual or automatic, as specified. The plant shall be started by an ON/OFF switch.

Additionally, in the case of an automatic plant, an auto/manual switch shall also be provided.

- ii) The automatic operation shall be effected through the monitoring of return chilled water temperature, or the room conditions, as the case may be. In multi unit installations, one unit shall be arranged to be loaded fully before the next unit is switched on automatically. A similar operation system shall be followed in shutting off of the unit. Change over from one operating unit to another shall be possible through the status switch of the plant to be shut down by change to manual position and thus overriding its anti-cycle timer. It should be possible to introduce the changed unit by running it to speed and changing over the status switch to "auto" position.
- iii) Pump down shut down shall be provided through low pressure (LP) safety irrespective of the status switch position, auto/manual.
- iv) It should be possible to start the compressor motor only after the cooling tower fan motor (where provided), chilled water (where provided) and condenser water pumps are operated.
- v) The compressor motor shall be able to be started or run, only after all the safeties as per para 12.2 are satisfied.
- vi) The blower motor shall be interlocked with strip heaters (where provided) such that power supply to strip heaters will become ON, only after the blower has been started and run to full (designed) speed.
- vii) Where only the blower motor and not heaters is connected to standby generating set in any particular application, a timer shall be provided, such that the heaters may get energised, only after a period of time, after the blower is run.
- viii) In the event of signal from high limit safety of heaters the power supply to the blower motor and the heater bank shall automatically and instantly be switched off.
- ix) The power supply to AHU shall be cut off on receipt of a signal from the Fire Alarm System.

12.6 REQUIREMENTS OF CONTROL ELEMENTS

The system control elements comprise controlling elements such as thermostats, humidistat, three way valves, heaters, humidifiers, dehumidifier etc as required for individual applications.

12.6.1 Thermostats

Thermostats shall be electric fixed differential type as indicated below, with sensing element located in the return air stream. All thermostats shall be supplied with the standard mounting boxes as recommended by the manufacturer. The profile, mounting arrangement and exact location of the thermostat shall be such as to suit the site.

- i) Proportional control thermostats shall be provided for actuating the three way modulating valve at each air handling unit. Thermostat shall provide manual switching (heat-off-cool-in heating-cooling system).
- ii) Snap-acting fixed differential type thermostat for actuating the three-way diverting valve at each fan coil unit.

Thermostat shall have temperature adjustments WARM-NORMAL-COOL settings and fan switch. Switching off must break fan circuit.

- iii) Snap-acting fixed differential heating thermostat for electric winter heating and reheat applications for putting on/off power supply to electric heating or reheat coils in air handling units.
- iv) Safety thermostat shall be provided for electric winter heating and reheat application for cutting off power supply to strip heaters in case air flow across strip heater is not established.
- vi) Air-stat shall be provided within air handling unit containing electric heating or reheat coils to prevent heaters from energizing unless the air flow is established.

12.6.2 Humidistat

Humidistat shall be provided with air handling unit for areas, which require humidity control. One humidistat shall activate the reheat coils in case the space humidity rises beyond the preset limit. Another humidistat shall energize the humidifier when the humidity falls below the preset limit. These humidistat shall also de-energize these devices when the desired humidity is reached.

Humidistat shall be snap-acting type having humidifier/dehumidifier control from 20-80 percent relative humidity, with differential of 5 percent. Humidistat shall have nylon element with three bobbins, and removable knob to prevent tempering of set point.

12.6.3 Three-way modulating valves (for AHUs)

These shall be provided in chilled/hot water lines as diverting valves at each air-handling unit and shall be actuated by a space thermostat. Space conditions shall be maintained by continuous proportional modulation of the chilled/hot water through the coil. The valve shall revert to fully bypass position when fan is shut off. Maximum pressure drop across valve shall not exceed 0.85 kg/ sq.cm. Where VSD (to control chilled water flow) is provided, the AHUs shall be provided with 2 way diverting valve.

12.6.4 Three-way diverting valves for FCUs

This shall be provided as 2 position diverting valves in chilled/hot water lines at each fan coil unit and shall be actuated by a space thermostat. Space conditions shall be maintained by allowing all of chilled/hot water to either pass

through the coil or bypass the coil and mix with the chilled/hot water return. The valves shall revert to fully bypass position when fan is shut off. Pressure drop across the valve shall not exceed 0.14 kg/ sq.cm. Valve shall have the facility to replace motor actuator without removing the valve body.

12.6.5 Spray humidifiers, where specified, shall be as per details given under para 6.2.3.6.1.

12.6.6 Pan humidifiers where provided shall be as per para 6.2.3.6.2.

12.6.7 Strip heaters shall be of finned type construction with a surface temperature not exceeding 45 deg. C. The same shall be suitable for 230 V, AC supply. The heaters shall be adequately insulated electrically from their mountings unit/ casing.

12.6.8 Dehumidifiers, where provided shall use adsorption type desiccants. The desiccant used shall be non-toxic, non-corrosive having a life of about 5 years with constant employment in regeneration cycle.

12.7 SPECIAL REQUIREMENTS FOR COLD STORAGEES

Automatic defrosting arrangement shall be provided in cold storages. The arrangement shall comprise stopping of the refrigeration system and providing defrosting using warm air or water as specified. Hot gas defrosting arrangement shall be provided where specified in particular applications.

12.8 VARIABLE SPEED DRIVE (VSD)

12.8.1 Air quantity flow control

The VSD System shall function to supply variable air quantity in the air-conditioned area in response to the load variations including that due to variations in ambient conditions and filter cleanliness conditions, to maintain the inside designed temperature, RH and pressure conditions in conjunction with the humidifier and re-heaters. During the day hours, as per the time interval selected, the VSD System shall regulate the speed of the AHU to maintain the temperature within maximum designed temperature and positive air pressure inside the air-conditioned area. The positive air pressure shall be maintained by keeping a difference of minimum 15% in the airflow between the supply and exhaust air. However, under any circumstances during the day hours, the air flow rate will not fall below the 60% of the rated CFM of the AHU or 15 air changes, whichever is higher. During the rest of the night hours, the Programmable timer shall give a signal to the VSD to run the AHU at a pre-determined reduced speed so as to provide only 25% of the normal CFM or the minimum CFM achievable closest to 25% but not below 25% of the normal CFM. Due to the clogging of the air filter if the inside temperature conditions are not achieved even at 100% AHU speed then the VSD will close an N.O. contacts to activate an alarm. The VSD shall have the provision to switch over to the manual mode as and when required. The system shall comprise of dedicated Variable Speed Drives (VSDs) designed for HVAC applications to accept 2 feedback signals (from temperature sensor installed in the AC area and programmable timer controller) and have 2 programmable set points (inside temperature conditions, and 60% of the normal CFM condition as stated above) using HVAC terminology, to regulate the speed of the AHU motors in response to the variations in load and filter cleanliness conditions to

maintain temperature and Air flow differential in supply and exhaust conditions. In case, any additional sensor (s) including wiring etc are required to meet the system requirements the cost of that shall be deemed to be included in the cost of the VSD. The VSD control shall have:

- a) RFI (Radio frequency interference) Filters for EMC (Electro magnetic compatibility) compliance.
- b) Voltage Vector Control technology to generate advanced sinusoidal output voltage, 100% true RMS value of the fundamental voltage at rated speed and nominal torque, cause no motor de-ration and keep motor temperature limits within permissible class B limits.
- c) Displays in user's friendly Alpha Numeric Characters for all operating parameters, programming parameters and faults.
- d) Built in energy meter.
- e) Built in run time counter.
- f) Local control panel (key pad)

The system shall also comprise a suitable programmable timer & PLC with required electronic components, to allow 2 feedback signals (Temperature & Minimum CFM) to be passed on to the VSD during the day hours. In the night hours only one signal from the programmable timer shall go to the VSD to run it at pre-determined reduced speed. The room/ space air temperature and air flow shall be sensed by a temperature and air flow transmitters, which shall generate suitable DC signal to provide feedback to the VSD, which in turn shall regulate the speed of the AHU fan to maintain the designed conditions as described above.

VSD shall be designed, with built-in PID controller, control panel (keypads & display), IP 20 enclosure for use on standard centrifugal fans. The VSDs should not cause any de-ration of the connected motors and must ensure that class B temperature levels of the connected motors are never exceeded. The display should be in alpha-numeric characters and programming facility should be in user-friendly HVAC terminology. The VSDs should be able to accept up to 2 feedback signal from temperature & air flow transmitter simultaneously and to program 2 set points in it.

The system shall also have following features incorporated :

- a) Heat sink over temperature protection
- b) Under voltage protection
- c) Over voltage protection
- d) Alpha-numeric display facilities
- e) ON indication
- f) Trip indication
- g) Selectable display of various parameters line voltage, frequency, speed, power, torque, motor temperature percentage, VSD temperature percentage, KWH.
- h) Raise and lower speed push button in local mode.
- i) Frequency range variation from 0 to 50 Hz.

- j) Remote start and stop facility including indications thereof with necessary hardware and terminal blocks, including toggle switch etc. to override remote start & stop at the time of maintenance/ repairs.
- k) Off delay facility through timer or PLC with 30 sec to 120 sec. time delay, to be connected to air flow switch.
- l) Safeguard facility against single phasing.
- m) Tripping of AHU blower motors in response to the fire alarm signal from AFAS.
- n) Inter locking of Exhaust and AHU blowers such that power supply gets fed to exhaust blower only when the supply air flow is there.

12.8.2 Chilled water flow control

Variable Speed Drive (VSDs) for controlling the chilled water flow rate in the secondary circuit may be provided when AHUs operation is for 24 hours and where the secondary chilled water system has been provided. Requirement and Specifications of VSD system shall be as follows:

The VSD System shall function to supply variable chilled water flow in the secondary circuit of air-conditioning system in response to the load variations including that due to variations in ambient conditions to maintain the inside designed temperature conditions. However, under any circumstances, the secondary chilled water pump speed shall not fall below the 30% of the nominal speed or any other suitable minimum speed as per the system requirement. The VSD shall have the provision to switch over to the manual mode as and when required and facility for the manual speed variation from VSD itself. The system shall comprise of dedicated Variable Speed Drives (VSDs) designed for HVAC applications to accept two feedback signals (from differential pressure transmitters installed across the two farthest, most significant AHUs of the zone to select either maximum of the two or average of the two (as selected by the user) feedback signals using HVAC terminology, to regulate the speed of the secondary chilled water pump motors in response to the load variations. In case, any additional sensor (s) including wiring etc. if required to meet the system requirements the cost of that shall be deemed to be included in the cost of the VSD. The VSD shall have:

- a) RFI (Radio frequency interference) Filters for EMC (Electro magnetic compatibility) compliance.
- b) Voltage Vector Control technology to generate advanced sinusoidal output voltage, 100% true RMS value of the fundamental voltage at rated speed and nominal torque, cause no motor de-ration, and keep motor temperature limits within permissible class B limits.
- c) The VSDs shall have D.C. link reactors/ harmonic filters integrated to minimise power line harmonics. There shall be reactors in both the positive and negative rails.
- d) An automatic energy optimisation feature shall be provided as standard in the frequency converter. This feature shall reduce output voltage, further to quadratic V/f characteristics, when the motor is lightly loaded and minimise the motor losses.
- e) The VSD shall be able to provide full rated output current continuously, 110% of rated current for 60 seconds and 160% torque for upto 5 seconds (for high inertic and high friction load).
- f) The VSD shall include Automatic Motor Adaptation (AMA) to optimize motor performance, improve start capabilities and compensate for motor cable variances. The AMA shall be carried out at motor stand still with no need for detaching the pump from motor.

- g) Unlimited output power circuit switching must be possible without the need for central circuit interlocking and without causing damage to the VSD.
- h) Auto-derating of maximum drive current shall be incorporated in VSD to allow continued operation at reduced speed in case of VSD over temperature phase loss or mains imbalance without damaging the VSD.
- i) Displays in user's friendly Alpha Numeric Characters for all operating parameters, programming parameters, faults,
- j) Built in energy meter.
- k) in run time counter.
- l) Local control panel (key pad)

The system shall also comprise a suitable PLC if required, with electronic components.

VSD shall be designed, with built-in PID controller, control panel (keypads & display), IP 20 enclosure for use on standard centrifugal pumps. The VSDs should not cause any de-ration of the connected motors and must ensure that class B temperature levels of the connected motors are never exceeded. The display should be in alpha-numeric characters and programming facility should be in user-friendly HVAC terminology. The VSDs shall be able to accept up to two feedback signals from differential Pressure transmitters simultaneously and to program set points in it.

The system shall have following features incorporated:-

- a) Heat sink over temperature protection
- b) Under voltage protection
- c) Over voltage protection
- d) Protections against input transients, loss of A.C. line phase, short circuit, ground fault, frequency converter over temperature.
- e) Alpha-numeric display facilities
- f) ON indication
- g) Trip indication
- h) Selectable display of various parameters like output line voltage, output frequency, speed, power, motor temperature percentage, heat sink temperature, VSD temperature percentage, KWH, hours run, differential pressure.
- i) Raise and lower speed push button in local mode.
- j) Frequency range variation from 0 to 50 Hz.
- k) Remote start and stop facility including indications thereof with necessary hardware and terminal blocks, including toggle switch etc. for over ride of remote start & stop of at the time of maintenance/ repairs.
- l) Safeguard facility against single phasing.

12.8.3 Where both building management system and air quantity flow control / chilled water flow control through VFD are provided for same application, control panel for sequencing of VFD shall not be required.

12.9 ECONOMIZER

12.9.1 Air- Side Economizers (Ambient Cooling)

Each individual cooling fan system that has a design supply capacity over 72 CMM (2,500 cfm) and a total mechanical cooling capacity over 22 kW (6.3 tons) shall include either:

- a) An air economizer capable of modulating outside-air and return-air dampers to supply 100% of the design supply air quantity as outside-air; or

- b) A water economizer capable of providing 100% of the expected system cooling load at outside air temperatures of 10°C (50°F) dry-bulb/7.2°C (45°F) wet-bulb and below

Exceptions to above are:

- a) Projects in the hot-dry and warm-humid climate zones are exempt
- b) Individual ceiling mounted fan systems < 192CMM (6,500 cfm) are exempt

12.9.2 Partial Cooling

Building's intrinsic thermal mass can be used to reduce peak cooling loads by circulating cool night-time air to pre-cool the building prior to daily occupancy in the cooling season. The building control system can operate ventilation fans in the economizer mode on a scheduled basis. Care should be taken to prevent excessive fan operation that would offset cooling energy savings. It should also be ensured that night humidity does not preclude the use of this strategy.

Economizers shall be capable of providing partial cooling even when additional mechanical cooling is required to meet the cooling load.

12.9.3 Testing of Air-Side Economizer

Air-side economizers shall be tested in the field following the requirements in Appendix M to ensure proper operation.

Exception to above:

Air economizers installed by the HVAC system equipment manufacturer and certified to the building department as being factory calibrated and tested per the procedures in Appendix M

12.10 ENERGY RECOVERY WHEEL

12.10.1 System features

- i) It shall have minimum recovery/ removal of 75 % - 80 % of total heat, that is both sensible and latent (each being 75 % - 80 %). The recovery of sensible and latent shall be equal.
- ii) The wheel shall be made of pure aluminum foil coated with molecular sieve desiccant with pore diameter of 3°A.
- iii) The cross contamination between the two air streams shall be nil and leakage less than 0.04%.
- iv) The vertical and radial run of the wheel shall be less than 1 mm per meter of diameter.
- v) The wheels shall have non-contact labyrinth seals for effective sealing between the two air streams.

12.10.2 Specifications

12.10.2.1 Substrate

The substrate or wheel matrix should be only of pure aluminum foil so as to allow:

- i) Quick and efficient uptake of thermal energy.
- ii) Sufficient mass for optimum heat transfer
- iii) Maximum sensible heat recovery at a relatively low rotational speed of 20 to 25 rpm.

Non metallic substrates made from paper, plastic, synthetic or glass fibre media, will therefore, not be acceptable.

The substrate shall not be made from any material which is combustible or supports combustion like synthetic fibrous media.

The rotor depth shall be minimum 270 mm to maximize recovery efficiency ratio.

12.10.2.2 Pressure drop

The pressure drop across the rotary heat exchanger shall not exceed 2.5mm for every 0.5mps face velocity, or part thereof, for the minimum stated/ required latent recoveries / efficiencies.

12.10.2.3 Desiccant

- i) The desiccant shall be water molecule selective and non-migratory.
- ii) The desiccant shall be of molecular sieve 3Å so as to keep the cross contamination to absolute minimum and also ensure the exclusion of contaminants from the air streams, while transferring the water vapor molecules.
- iii) The desiccant, of sufficient mass which shall not be less than 5 kg per 1000 CFM of air, shall be coated with non-masking porous binder adhesive on the aluminum substrate so as to allow quick and easy uptake and release of water vapor.
- iv) The rotor/wheel matrix shall have equal sensible and latent recovery.
- v) The weight of desiccant coating and the mass of aluminum foil shall be in a ratio so as to ensure equal recovery of both sensible and latent heat over the operating range.

12.10.2.4 Rotor

- i. With optimum heat and mass through matrix formed by desiccant, of sufficient mass, coated on an aluminum foil, the rotor should rotate at lower than 20 to 25 RPM, thereby also ensuring long life of belts and reduced wear and tear of seals.
- ii. The rotor shall be made of alternate flat and corrugated aluminum foil of uniform width.
- iii. The rotor honeycomb matrix foil should be so wound and adhered as to make a structurally very strong and rigid media which shall not get cracked, deformed etc. due to change of temperature or humidity.
- iv. The rotor having a diameter upto 2800 mm shall have spokes to reinforce the matrix.

- v. From 2000 mm diameter upwards, the option of a special wing structure, to prevent the rotors from wobbling or deforming due to the successive pressure differentials, will be available.
- vi. Sectioned wheels, with pie segments, capable of being assembled in the field, shall be available as an option, above 2000 mm in diameter.
- vii. The surface of the wheel/rotor shall be highly polished to ensure that the vertical run out does not exceed + 1 mm for every 1 metre diameter, thereby ensuring, negligible leakage, if labyrinth non contact seals are provided, and minimal drag, if contact wiper seals are provided.
- viii. The radial run out also shall not exceed + 1 mm for every 1 meter diameter, thereby minimizing the leakage/drag on the radial seals, and minimize the fluctuation in the tension of the drive belt.
- ix. The rotor shall be a non clogging aluminum media, having a multitude of narrow aluminum foil channels, thus ensuring a laminar flow, and will allow particles upto 800 microns to pass through it.
- x. The media shall be cleanable with compressed air, or low pressure steam or light detergent, without degrading the latent recovery.

12.10.2.5 Cassette/Casing

The recovery wheel cassette/casing shall be manufactured from tubular / sheet metal structure to provide a self-supporting rigid structure, complete with access panels, purge sector, rotor, bearings, seals, drive mechanism complete with belt.

The rotor/wheel should have a field adjustable purge mechanism to provide definite separation of airflow minimizing the carryover of bacteria, dust and other pollutants, from the exhaust air to the supply air. It shall be possible, with proper adjustment, to limit cross contamination to less than 0.04% of that of the exhaust air concentration.

12.10.3 Passive desiccant wheel system

System features

- i. The desiccant honeycomb rotor media shall be adsorbent, non toxic, non flammable, fully water washable.
- ii. The substrate of the rotor shall not be made from asbestos or any synthetic material, and shall not have any toxic desiccants impregnated like lithium chloride, etc.
- iii. The desiccant media shall have in-situ synthesized metal silicate desiccant on an inert inorganic fibre substrate. The synthetic media shall not be acceptable.
- iv. The usable desiccant mass shall be at least 80% of the media weight, so as to ensure high performance and minimal heat carry over.
- v. The net organics in the honeycomb media shall not exceed 2%.
- vi. The desiccant rotor shall have integral long life bearings supported by a simple fixed shaft design to allow a simple slide out of the rotor/bed.
- vii. The desiccant media shall have a perimeter flange which should encircle the entire perimeter so as to allow greater durability and to roll the rotor on the ground, without damage. The perimeter flange should be smooth and consistent to serve as a perimeter seal surface, thus ensuring long life for the perimeter seal, without being cut, torn or otherwise damaged.
- viii. The desiccant media shall not fracture due to repeated temperature and moisture

- cycling and all the materials of construction shall be non toxic.
- ix. The surface of the media shall have a special edge hardening so as to ensure a smooth surface and long life of both the media and the seal contacting it.
 - x. The desiccant media shall not use any organic burn off process, as this shall weaken the media structure.

12.11 TIMECLOCK CONTROL

All mechanical cooling and heating systems shall be controlled by a timeclock that:

- i) Can start and stop the system under different schedules for three different day-types per week.
- ii) Is capable of retaining programming and time setting during loss of power for a period of at least 10 hours
- iii) Includes an accessible manual override that allows temporary operation of the system for up to 2 hours

Exceptions to the above are:

- i) Cooling systems < 28 kW (8 tons)
- ii) Heating systems < 7 kW (2 tons)

12.12 TEMPERTAURE CONTROL

- i) All heating and cooling equipment shall be temperature controlled. Where a unit provides both heating and cooling, controls shall be capable of providing a temperature dead band of 3° C (5° F) within which the supply of heating and cooling energy to the zone is shut off or reduced to a minimum. Where separate heating and cooling equipment serve the same temperature zone, thermostats shall be interlocked to prevent simultaneous heating and cooling.

12.13 DEMAND BASED CONTROL

Conventional HVAC controls employ pressure -or temperature-set point control to isolate (or decouple) one system element from another. In any air conditioning plant, the cooling towers, chillers, distribution pumps, and supply fans are controlled independently with temperature or pressure set points that ensure the surrounding equipment also can operate independently over a wide range of loading requirements. Although a network-capable direct-digital-control (DDC) system may be employed for control, the network typically is used only to collect information for operations. In many systems, additional isolation is provided with primary -secondary pumping, bypasses, decoupling lines, and valves or dampers that have large pressure drops.

This focus on independent equipment selection wastes a lot of energy. In this system, normally the chiller will operate at a fixed chilled water temperature. At low load conditions, the chiller compressor would operate at a higher than needed head to provide colder water than required which the chilled water pump will distribute at a higher pressure than what is required. All these bring inefficiency into the system though the individual controls are provided to control them.

Demand-based control is a method of applying direct-coupled network control. It is based on the idea that a building HVAC system is a single system the energy

efficiency and comfort performance of which are optimized when the operation of all the components is coordinated to meet actual needs in the spaces served.

Demand based control is intended to fill the vacuum created by development of variable frequency drive for HVAC equipment.

Demand based control ties the operation of all the equipment to end use requirements- actual space requirement in single building HVAC applications but this does not mean that chillers and cooling towers operate directly from the room temperature sensor. Rather in this control, all the components of air conditioning plant are directly coupled and work as a single system.

With variable-speed equipment and network capabilities, the long standing dictum that equipment must be decoupled to operate effectively has been reversed. Direct coupling leads to simpler, more-efficient operation. It is intuitive that coordinating the operation of a chiller plant and chilled-water distribution network is required to achieve the highest overall cooling system efficiency. When cooling needs to adjust in response to space conditions, demand based control coordinates the operation of all elements to provide cooling where it is needed according to predefined efficiency relationship.

Equal marginal performance principle is applied to optimize the pumps operation under all loading conditions. A circuit consisting of cooling towers, chiller pumps, and conditioning fans with VSD could be optimized in this manner. These components could be directly coupled and controlled using demand-based control to operate the circuit as a single system and provide the cooling capacity required. Thus, with demand-based control, equipment is coordinated to operate according to power (kilowatt) set points, which is simpler, more stable, and much more efficient than the use of temperature or pressure set points is.

CHAPTER-13

ELECTRICAL WORK

13.1 SCOPE

This chapter covers the requirements for the electrical works associated with heating, air conditioning, ventilation and cold room applications, namely, switch boards, power cabling, control wiring, earthing, p.f. capacitors and remote control-cum-indicating panels. Electric motors are not covered here, as these are covered as part of the respective equipment specifications.

13.2 GENERAL

- i) Unless otherwise specified in the tender specifications, all equipments and materials for electrical works shall be suitable for continuous operations on 415 V / 240 V \pm 10%(3 phase/single phase), 50 Hz. AC system. Where the use of high voltage equipments is specified in particular works, all the respective equipments shall be suitable for continuous operation on such specified high voltage.
- ii) All electrical works shall be carried out complying with the Indian Electricity Rules, 1956 as amended to date.
- iii) All parts of electrical works shall be carried out as per appropriate CPWD General specifications for Electrical works, namely, Part I (Internal) 2013, Part II (External) 1994 work, and Part IV (Sub-station), 2013 all as amended to date.
- iv) All materials and components used shall conform to the relevant IS specifications amended to date.

13.3 SWITCH BOARDS

- i) The main switch board in the A.C. plant room shall be floor mounted, free standing cubical type and shall be factory built fabricated by one of the reputed switch board manufacturer. It shall be suitable for termination of the incoming cable(s)/ bus trunking from top/ bottom. The switchboards in air handling unit (AHU) rooms shall be wall mounted, or floor mounted as feasible at site and as approved by the Engineer-in-charge, but they shall be cubical design, unless otherwise specified and open able from front.
- ii) The capacity of switch gear, starters etc. shall be suitable for the requirements of loads fed/controlled. Starting currents shall be duly considered in case of motor loads.
- iii) Switch fuse units shall be used upto and including 63 A and fuse switch units shall be used for 100 A and above. ACB shall be used for 630 A and above ratings.

- iv) All switch fuses/fuse switches dis-connector switches shall be of AC 23 duty as per IS: 4064-1978 as amended upto date. They shall be complete with suitable HRC cartridge type fuses.
- v) Switch boards controlling motors shall house starters for motors, unless otherwise specified. Independent single phasing preventors for each such starter shall be provided. The starter and SPP shall be located adjacent to the controlling switch gear.
- vi) One volt meter with selector switch, a set of indicating lamps and fuses for voltmeter and lamps shall be provided at each switchboard. One ammeter with CTS, and selector switch shall be provided with each motor starter. Instruments shall be flush mounted with the panel and have a glass index not higher than 1.5. The instruments and accessories shall be provided whether or not specifically indicated in the tender specifications.
- vii) The fabrication of switchboard shall be taken up only after the drawings for the fabrication of the same are approved by the Engineer-in-charge.
- viii) Switchboards shall be fabricated as per specifications indicated in sub-para above.
- ix) The layout of bus bars and cable alleys shall be designed for convenient connections and inter-connections with the various switchgear. Connections from individual compartments to cable alleys shall be such as not to shut down healthy circuits in the event of maintenance work becoming necessary on a defective circuit.
- x) Care shall be taken to provide adequate clearances between phase bus bars as well as between phase bus bars, neutral and earth.
- xi) Where terminations are done on the bus bars by drilling holes therein, extra cross section shall be provided for the bus bars. Alternatively, terminations may be made by clamping.
- xii) Provision shall be made for proper termination of cables at the switchboards such that there is no strain either on the cables, or on the terminators. Cables connected to the upper tiers shall be duly clamped within the switchboard.
- xiii) Identification labels shall be provided against each switchgear and starter compartment, using plastic engraved labels.
- xiv) Metallic danger board conforming to relevant IS shall be fixed on each electrical switchboard.
- xv) Switchboard housing only isolators near cooling towers shall be housed in weather proof enclosure. The mounting arrangement shall be as approved by the Engineer-in-Charge to suit the site conditions.

13.4 POWER CABLING

- i) Unless otherwise specified, the power cables shall be XLPE insulated, PVC outer sheathed aluminium conductor, armoured cables rated for

1100 V grade. The power cables shall be of 2 core for single phase, 4 core for sizes upto and including 25 sq.mm, 3-1/2 core for sizes higher than 25 sq.mm for 3 phase. Where high voltage equipments are to be fed, the cables shall be rated for continuous operation at the voltages to suit the same.

- ii) Power cables shall be of sizes as indicated in the tender specifications. In all other cases, the sizes shall be as approved by the Engineer-in-Charge, after taking into consideration the load, the length of cabling and the type of load.
- iii) Cables shall be laid in suitable metallic trays suspended from ceiling, or mounted on walls, or laid directly in ground or clamped on structures, as may be required. Cable ducts shall not be provided in plant rooms. Cable trays shall be fabricated from slotted angle/solid angles to make ladder type cable tray, designed with adequate dimensions for proper heat dissipation and also access to the cables. Alternatively, cable trays may be of steel sheet with adequate structural strength and rigidity, with necessary ventilation holes therein. In both the cases, necessary supports and suspenders shall be provided by the Air-conditioning Contractor as required.
- iv) Cable laying work shall be carried out in accordance with 13.4 (iii) above. The scope of work for the Air-conditioning Contractor shall include making trenches in ground and refilling as required, but excludes any masonry trenches for the cable work.

13.5 CONTROL WIRING

- i) Control wiring in the plant rooms and AHU rooms shall be done using ISI marked PVC insulated and PVC sheathed, 1.5 sq.mm copper conductor, 250 V grade, cables drawn in ISI marked steel or PVC conduits. Alternatively, armoured multi-core copper conductor cables may also be used for the purpose. The control cables interconnecting the plant room and the AHU rooms shall be of multi-core armoured type only, and suitable for laying direct in ground.
- ii) The number and size of the control cables shall be such as to suit the control system design adopted by the Air-conditioning Contractor.
- iii) ISI marked steel conduit pipes, wherever used, shall be of gauge not less than 1.6 mm thick for conduits upto 32 mm dia and not less than 2.0 mm thick for higher sizes. All conduit accessories shall be threaded type with substantial wall thickness.
- iv) Control cables shall be of adequate cross section to restrict the voltage drop.
- v) In the case of control wires drawn through steel conduits, the wire drawing capacity of conduits as specified under the CPWD General Specifications for Electrical Works (Part I) 1994 shall not be exceeded.
- vi) Runs of control wires within the switchboard shall be neatly bunched and suitably supported/clamped. Means shall be provided for easy identification of the control wires.

- vii) Control wiring shall correspond to the circuitry/sequence of operations and interlocks approved by Engineer-in-Charge.
- viii) In cold storage involving temperatures below zero deg. C, polythene cables shall be used instead of PVC cables.

13.6 EARTHING

- i) Provision of earth electrodes and the type of earthing shall be as specified in the tender specifications.
- ii) The earth work shall be carried out in conformity with CPWD Specifications for Electrical works (Part-I), Internal 1994.
- iii) Metallic body of all medium voltage equipments and switch boards shall be connected by separate and distinct earth conductors to the earth stations of the installations; looping of such body earth conductors is acceptable from one equipment, or switch board to another.
- iv) G.I. plate earthing shall be provided for PTAC plants and reciprocating central AC plants upto 100 TR capacity. Above 100 TR reciprocating units and centrifugal/ screw chilling units copper plate earthing shall be provided.
- v) The size of earth conductors for body earthing of equipments shall be as under: -

Motors upto and including 10 HP rating	2 Nos. 3 mm dia copper wire/ 2 nos. 4mm dia GI wire
12.5 HP to 40 HP	2 Nos. 4 mm dia copper wire/ 2 nos. 6mm dia GI wire
50 HP to 75 HP	2 Nos. 6 mm dia copper wire/ 2 nos. 25x3mm GI strip
Above 75 HP	2Nos. 25mm x 3mm copper strip/ 2 nos. 25x6mm GI strip
Switch boards with incoming rating	
Upto 100 A	2 Nos. 3 mm dia copper wire/ 2 nos. 4mm dia GI wire
125 A to 200 A rating	2 Nos. 6mm dia copper wire/ 2 nos. 25x3mm GI strip
Above 200 A rating	2 Nos. 25mm x 3mm copper strip/ 2 nos. 25x6 mm GI strip

- vi) Armouring of cables shall be connected to the body of the equipments/switch board at both the ends. Compression type glands shall be used for all such terminations in the case of PVC cables.

13.7 POWER FACTOR CAPACITORS

- i) PF capacitors shall be provided for all motor loads of 5 HP and above. These capacitors shall come into circuit when the respective motor load is switched on. For this purpose, necessary interconnections between

the capacitors and the motors/starters shall be included in the scope of work of the Air-conditioning Contractor.

- ii) The power capacitors shall be of such value as to improve the PF to 0.90 lagging when the motor is running at full load. In the case of large size motors, the capacitors may be made in suitable banks so that the required bank(s) of capacitors may be switched under partial load conditions. Such operations of individual banks shall be automatic.
- iii) Where the PF capacitors are provided in banks, each bank shall be controlled by suitably rated switch gear with HRC fuses.
- iv) The capacitor banks and the controlling switchgear may be fabricated in independent cubical or may form part of the switchboard in the installations. In the latter case, the capacitors are permitted to be mounted on the switchboard, if so desired.

13.8 REMOTE CONTROL CUM INDICATING PANEL

- i) The remote control cum indicating panel shall be provided in the plant room. This panel shall have necessary push buttons for on and off controls and status indication of all electric motors except for small motors as of humidifiers of AHUs and FCUs. **However , if BMS system is provided , remote control-cum- indicating panel shall not be required.**
- ii) In view of (i) above, push buttons need not be provided as part of the starters in the switch boards, except of the AHU blower motors. In the case of the AHU blower motors, push buttons shall be provided as part of the starters for local on and off operations.
- iii) Back indication to show the status of operation of all the motors (except small motors as in humidifiers of AHUs and FCUs) and also of the electric strip heaters (AHU wise) shall be provided.
- iv) Panel shall be fabricated from 1.6 mm thick steel sheet. This shall be of freestanding floor mounting type design. This shall be complete with necessary termination arrangements, multicore cables, tag blocks, control transformer, designation plastic labels, double earth studs etc. as required.

13.9 MOTOR STARTER

- i) The motor starter shall conform to IS: 1822 "Motor starters of voltage not exceeding 1000 volts" and shall be air insulated and suitable for 415 volts, $\pm 10\%$, 50 Hz., 3 phase AC supply. Enclosures shall have protection of IP 42 for Indoor applications and IP 55 for outdoor applications.
- ii) Starter for the motor shall be direct on line (D.O.L) for motors up to and including 7.5 H.P. rating and automatic star-delta close transition type for motors of higher ratings unless otherwise specified in the tender specifications. Starters shall be rated for intermittent duty. Starting current should not exceed two times the full load current.

- iii) Reciprocating chiller shall be fitted with part winding starter and housed in chiller panel.
- iv) The starter shall be mounted on the main electrical control panel/ unit mounted/ self mounted as specified.
- v) Each starter shall be provided with the following protections: -
 - a) Thermal overload on all the three phases with adjustable settings,
 - b) Under voltage protection, and
 - c) Independent single phasing preventor. (current sensing type)
- vi) Adequate number of extra NO/ NC contacts for interlocks, indicating lamps etc. shall be provided on the starter/ contactor.

13.10 PAINTING

All panels shall be supplied with the manufacturer's standard finish painting or as indicated in the Schedule of Work.

13.11 MOTOR EFFICIENCY

1. All permanently wired poly-phase motors of 0.375 kW or more serving the building and expected to operate more than 1500 hours per year and all permanently wired poly phase motors of 50 kW or more serving the building and expected to operate more than 500 hours per year shall have a minimum acceptable nominal full load motor efficiency not less than IE3 class as per IS 12615 for Energy Efficient motors.
2. Motors of horsepower differing from those listed in the table shall have efficiency greater than that of the listed kW motor. See Annexure N.
3. Motor horsepower ratings shall not exceed 20% of the calculated maximum load.
4. Motor nameplates shall list the nominal full load motor efficiencies and the full load power factor.
5. Motor users should insist on proper rewinding practices for rewind motors. If the proper rewinding practices cannot be assured, the damaged motor should be replaced with a new, efficient one rather than suffer the significant efficiency penalty associated with typical rewind practices.
6. Certificates shall be obtained and kept on record indicating the motor efficiency. Whenever a motor is rewind, appropriate measures shall be taken so that the core characteristics of the motor is not lost due to thermal and mechanical stress during removal of damaged parts. After rewinding, a new efficiency test shall be performed and similar records shall be maintained.
7. Motors should be installed with soft start energy savers and Variable Speed drives based on the application required.

CHAPTER -14

CENTRAL HEATING SYSTEM

14.1 SCOPE

A central heating system includes hot water generator and associated works like Factory built air handling units, Fan coil units, Water circulating pumps, Ducting, Water plumbing work, insulation work, controls & control wiring & electrical works. Specifications for all associated works are same as for air-conditioning works covered from chapter 6 to 13. For system design para 2.2 may be referred.

This chapter covers the requirements of hot water generator, of electrically heated type, for generating hot water for space heating and air conditioning application.

This chapter does not cover central heating through reverse cycle system as the same has already been discussed earlier under para 2.2.3 & 2.2.4 (chapter 2) and para 6.25 (chapter 6).

14.2 ELECTRICALLY OPERATED HOT WATER GENERATOR

- i) The hot water generator shall be cylindrical in shape, fabricated out of MS sheet of 10 mm thickness in robust welded construction. It shall be complete with necessary supports for free standing on floor, such that the bottom of the shell is 300 mm above the finished floor level.
- ii) Shell shall be complete with necessary lifting lugs, and provisions for inlet and outlet connections, drain connections, and heating elements.
- iii) Shell shall be insulated with non-setting, non-corrosive glass wool insulation blanket. This shall be covered with 2 mm thick aluminium sheet, or 1.25 mm thick MS sheet, painted with heat resistant paint. The surface temperature of the cladding shall not be exceeding 45 deg. C.
- iv) Electric heating elements shall be replaceable, immersion type having solid copper facing designed for low heat concentration, not exceeding 70 W/ 1000 sq.mm. The elements shall be located near the bottom of the shell. The number as well as wattage of the elements shall be clearly indicated in the technical particulars by the Air-conditioning Contractor so as to guarantee production of hot water at the specified rate.
- v) The elements shall be connected to suitable terminal box with hinged cover and shall be complete with provision for termination of electric supply cables, as required. The elements shall be distributed in 3 phase equally for balanced loading, and shall be brought out in the terminal box for switching in stages as required. The number of stages shall be indicated by the Air-conditioning Contractor.
- vi) Suitably rated contactors shall be housed in the control box mounted on or near the hot water generator for the switching of the heater elements in the desired stages. This shall be complete with necessary

interconnecting wiring/cabling between the control box and terminal box.

- vii) Hot water generator shall be provided with but not restricted to the following accessories.
 - a) Safety valve,
 - b) Drain valve,
 - c) Pressure release valve,
 - d) Vent cock,
 - e) Thermometer,
 - f) Pressure gauge
 - g) Electrically operated pressure switch

14.3 PAINTING

All equipment shall be supplied with the manufacturer's standard finished painting.

CHAPTER –15

MECHANICAL VENTILATION SYSTEM AND ETAC PLANTS

15.1 SCOPE

This chapter includes supply air fan, exhaust air fan and evaporative type air cooling plant. Specification for all associated works such as ducting, plumbing, electrical works etc are same as for air-conditioning works covered under chapter 9, 10 and 13. For system design para 2.3 may be referred.

15.2 CENTRIFUGAL FANS

- i) Centrifugal fans shall be of double-width, double-inlet construction, with bearing on both sides, complete with access door, squirrel-cage induction motor, V-belt drive, belt guard etc.
- ii) Housing shall be of heavy gauge sheet steel in welded construction. It shall be rigidly reinforced and supported by structural angles. Split casing shall be provided on larger sizes of fans. However neoprene/asbestos packing shall be provided throughout split joints to make it airtight. 1.2 mm galvanised wire mesh inlet guard, of 5 cms sleeves shall be provided on both inlets. Housing shall be provided with access door with quick locking tension handles and neoprene gasket. Rotation arrow shall be clearly marked on the housing.
- iii) Fan wheel shall be of GSS and backward curved non-overloading type unless otherwise specified. Fan wheel and housing shall be statically and dynamically balanced. Fan outlet velocity shall not exceed 610 meters per minute.
- iv) Shaft shall be constructed of steel, turned, ground and polished.
- v) Bearings shall be of the sleeve/ball bearing type mounted directly on the fan housing. Bearing shall be self-aligned, oil grease packed, pillow block type.
- vi) Drive to fan shall be provided from 3 phase electric motor through belt with adjustable motor sheave and belt guard. Belt shall be of the oil resistant type. The number of belts shall be not less than two.
- vii) Drive motor shall be in accordance with para 6.2.3.4.(v).
- viii) Motor starter shall be in accordance with para 13.9.

15.3 AXIAL FLOW FANS

- i) Casing shall be constructed of heavy gauge sheet steel. Casing shall be provided with hinged door enabling easy replacement of wheel,

shaft and bearings. A small inspection door with handle and neoprene gasket shall also be provided. Casing shall have flanged connection on both ends for ducted applications. Support brackets for ceiling suspension shall be welded to the casing for connection to hanger bolts.

Straightening vanes shall be aerodynamically designed for maximum efficiency by converting velocity pressure to static pressure potential and minimizing turbulence. Casing shall be de-rusted, cleaned, primed and finish coated with enamel paint.

- ii) Rotor hub and blades shall be of cast aluminium, or cast steel construction. Blades shall be die-formed aerofoil shaped for maximum efficiency and shall vary in twist and width from hub to tip to effect equal air distribution along the blade length. Fan blade mounting on the hub shall be statically and dynamically balanced. Extended grease leads for external lubrication shall be provided. The fan pitch control maybe manually readjust able at site, upon installation, for obtaining actual airflow values, as specified.
- iii) Motor shall be of 3 phase squirrel-cage totally enclosed, fan cooled type. Motor and starter shall be in accordance with para 6.2.3.4(v) and 13.9 respectively. The speed of fan shall not exceed 1000 RPM for fans with impeller diameter above 450 mm, and 1450 RPM for fans with impeller diameter of 450 mm and less.
- iv) Drive :

For Duct/Wall Mounted Fan:

For duct/wall mounted fans the impeller shall be mounted directly on the motor. Drive unit and impeller shall be totally enclosed inside the duct.

For Floor/Ceiling Mounted Fan:

The fan shall be provided with belt drive and adjustable motor sheave, standard sheet steel belt guard with vented front for heat dissipation. Belt shall be of the oil resistant type.

- v) **Vibration Isolation**

Base shall be provided for each fan. Base for both fan and motor shall be built as an integral part and shall be mounted on a concrete foundation through cushy foot vibration isolators. The concrete foundations shall be at least 15 cm above the finished floor level and shall be further isolated from the structural floor through 5 cm. Thick layers of sand all around, topped with bitumen. In case ceiling hung fan within the ceiling shall be provided Vibration Isolation Suspension (VIS) shall be provided in each of string.

15.4 PROPELLER FANS

- i) Propeller fans shall be direct-driven, three or four blade type, mounted on a steel mounting plate with orifice ring.
- ii) Mounting plate shall be of heavy gauge sheet steel construction, streamlined venturi inlet (reversed) for supply applications. The size shall suit the fan size.
- iii) Fan blades shall be constructed of aluminium or steel. Fan hub shall be of heavy welded steel construction with blades bolted to the hub. Fan blades and hub assembly shall be statically and dynamically balanced at the factory.
- iv) Motor shall be standard (easily replaceable) single phase, permanent split capacitor or shaded pole for small sizes, totally enclosed with pre-lubricated sleeves or ball bearings, designed for quiet operation with a maximum speed of 1000 RPM for fans of 3 cm. dia or larger and 1440 rpm for fans of 31 cm. dia and smaller. Motors for larger fans shall be suitable for 415 \pm 10% volts, 50 cycles, 3 phase, power supply. Motors shall be suitable for either horizontal or vertical services, as indicated in drawing/ schedule of quantities.
- v) The following accessories may be required and provided with propeller fans, as indicated in the tender specifications.
 - a) Wire guard on inlet side and bird screen at the outlet.
 - b) Gravity operated louver shutters built into a steel frame.
 - c) Regulators for controlling fan speed for single phase fan motors.

15.5 ROOF MOUNTED FANS

- i) Roof mounted fans shall be propeller type or centrifugal fans, direct driven or belt driven, complete with motor drive and housing with weather-proof cowl.
- ii) Housing shall be constructed of heavy gauge steel sheet. The housing shall have adjustable flange to facilitate installation and shall be especially adapted to receive fan, motor, and drive. The housing shall have a low silhouette. For belt driven units, motor shall be installed in ventilated water proof housing outside the air stream. The discharge cowl shall be hinged along one edge for easy access to motor and drive for inspection and maintenance. The entire assembly shall be weatherproof and raised from the roof terrace sufficiently to prevent down flow of rain water accumulated on the terrace. Galvanised steel mesh bird screen shall be provided on all discharge cowls around the outlet areas.
- iii) Fans shall be backwardly inclined centrifugal wheel or propeller type as required, designed for maximum efficiency, minimum turbulence and quiet operation. Fan shall be statically and dynamically balanced.
- iv) Single phase motor shall be shaded pole with permanently lubricated sleeve bearing, or split capacitor type with permanently lubricated sleeve or ball bearings, designed for quiet operation. Bearing shall be

designed for vertical mounting. Motor name plate horsepower shall be such that the motor shall not be overloaded in the entire range of rated speed. Motor and fan assembly shall be easily removable. Motor's power supply characteristic and maximum speed shall be as specified for propeller fans.

- v) Fan bearings shall be heavy duty, self-aligning sleeve/ball bearing designed for thrust load and sealed for grease retention.
- vi) Backdraft damper shall be provided where specified. Roof mounted fan shall be equipped with rattle-free backdraft damper to prevent air from re-entering the fan when fan is not in operation, thus sealing completely in closed position. Damper shall be shatterproof.

15.6 EVAPORATIVE TYPE AIR COOLING (ETAC)

- i) The ETAC unit shall be of double skin construction draw-through type comprising of various sections such as filter section, cellulose deck bed section and supply air fan section.
- ii) Housing of air handling unit shall be of double skin construction. The frame work shall be of extruded aluminium hollow section. All the frames shall be assembled using pressure dye cast aluminium joints of various sections, strong and self-supporting frame work of various sections. The double skin panels shall be 25mm thick and shall be made of 0.8mm pre-painted GSS sheet on outside and 0.63mm pre-painted GSS sheet on inside with 25mm thick PUF insulation injected in between by injection moulding machine. These panels shall be screwed on to the frame work with soft rubber gasket in between to make the joints air-tight. Suitable air-tight access doors with hinges and locks shall be provided for access to various sections for maintenance. The entire housing shall be mounted on extruded aluminium channel frame work having pressure dye cast aluminium joints.
- iii) Fan: The fan shall be backward curved double inlet, double width type. The wheel and housing shall be fabricated from heavy gauge galvanised steel. The fan impeller shall be mounted on a solid shaft supported to housing with angle iron frame work and pillow block heavy duty ball bearing. The impeller and fan shall be statically and dynamically balanced. The fan shall be selected for a speed not exceeding 1000 RPM. Frame housing with motor shall be mounted on a common extruded aluminium base mounted inside the housing on anti-vibration mounds. Fan outlet shall be connected to casing with the help of fire retardant fabric acting as flexible connection for anti-vibration. The manual dampers shall be installed at the outlet of the unit. The damper should be air-tight and should be in a position to prevent back flow.
- iv) Wet Deck humidifier: The humidifier pads shall be of cellulose paper minimum 200mm deep which shall be housed in a galvanised steel case complete with water distribution header and interconnecting heavy duty PVC pipe between pump and distribution header. The water

circulation pump shall be vertical type. The suction portion shall be at the bottom with proper sealing arrangement to directly pick up water from the tank. The pump shall be suitable for the operation on 3-phase 415 \pm 10% volt A.C. supply.

The tank shall be of stainless steel sheet of thickness not less than 1.6mm, having necessary arrangement for inlet water with float valve over flow and drain arrangement.

- v) Filter section : The unit shall be provided with factory assembled filter section containing washable air filter having bounded expanded aluminium media with frame. The filter media and frame shall be rust proof and corrosion resistant. The filter shall be fitted so as to prevent by-pass and it shall be possible to remove the filters easily.
- vi) Motor & Drive: The fan motor shall be suitable for 415 \pm 10% volts 50 cycle 3 phase squirrel case totally enclosed fan cooled with IP 55 protection. The motor speed shall not exceed 1450 rpm. The drive to the fan shall be provided through belt arrangement.

15.7 EXHAUST UNIT

The construction of the exhaust unit shall be identical with that of the air washer unit except that the exhaust unit will not have filters and humidifiers.

15.8 TWO STAGE EVAPORATIVE COOLERS

Evaporative coolers are cooling systems that use only water and a blower to circulate air. In the system, warm, dry air is pulled through a water-soaked pad. As the water evaporates, a cooling effect on the surrounding air occurs. Evaporative coolers use only a fraction of the energy of traditional air conditioning systems. Unfortunately, except for in very dry climates, they may increase humidity to a level that makes occupants uncomfortable. Two-stage evaporative coolers do not produce humidity levels as high as that produced by traditional single-stage evaporative coolers.

15.8.1 Features

- i) In the first stage of a two-stage cooler, warm air is pre-cooled indirectly without adding humidity (by passing inside a heat exchanger that is cooled by evaporation on the outside).
- ii) In the direct stage, the precooled air passes through a water-soaked pad and picks up humidity as it cools. Because the air supply to the second stage evaporator is pre-cooled, less humidity is added to the air (because cooler air can't hold as much moisture as warmer air).
- iii) This result in a cool air with a relative humidity between 50 and 70 percent, depending on the climate, compared to a traditional system that produces about 80 percent relative humidity air.

- iv) An advanced two-stage evaporative cooler uses 100 percent outdoor air and a variable speed blower to circulate cool air.

15.8.2 Benefits

- i) Two-stage evaporative coolers can reduce energy consumption by 60 to 75 percent over conventional air conditioning systems.
- ii) This relative improvement depends on location and application. Evaporative coolers work best in very dry climates.

15.9 PACKAGE TYPE AIR WASHERS:

15.9.1 The packaged type air washer shall be complete in all respect and shall generally comply with the following specifications given below.

15.9.2 AIR WASHERS

The packaged air washer shall be of GI sheet metal sectionalized construction and shall include fan section, cooling pad section, motor drive etc.

i) Fan Section:

The impellers of the fan or fan shall be of GI sheets, double inlet backward curved centrifugal design, both statically and dynamically balanced. The fan housing shall be of sturdy construction made from double skinned GSS casing having 0.6mm pre-coated GI sheet outside and plain 0.6mm thick GI sheet inside with 25 mm thick puff insulation with smooth air inlets. The fan shall be mounted on properly aligned shaft and mounted on self-aligning bearing blocks. The casing of the fan section shall be made of 16 G (1.6mm) GI sheets suitably reinforced to provide rigidity. The frame work shall either be folded G.I. sheets or of hot dipped galvanized iron.

The fan section shall be complete with V belt drive, belt guard and motor mounting base.

ii) Cooling Pad:

The cooling pads shall be of honey comb design to provide extended and sufficient wetted surface to give a water absorbing efficiency of at least 80% at an air velocity of 3.0 m/sec.

The cooling pads shall be made of either acetate paper or high impact PVC. The cross section and depth shall be sufficient for specified efficiency. The cooling pad section shall be of 16 G (1.6mm) G.I. sheet similar to fan section. It shall be complete with galvanized supports for mounting the pads and a water distribution through the uniform supply of water over the entire surface.

iii) **Water Sump:**

The water sump below the pad section shall be of minimum 1mm SS 304. The tank shall be complete with makeup, overflow and drain connections. A float valve shall be provided for makeup water line.

The pump set shall be of construction, with end suction and top discharge with flanged connections, bronze impeller and casing all mounted directly on a squirrel cage, drip proof induction motor of suitable capacity.

15.9.3 **MOTORS:**

The motor for each blower shall be totally enclosed, fan cooled, squirrel cage induction type and conform to specifications, class F insulation with IP 55 protection.

15.9.4 **MISCELLANEOUS:**

Necessary accessories shall be provided wherever necessarily required for proper operation and shall also include:

- i) Necessary GI piping for water circulation
- ii) Vibration isolations pads for the blowers and pumps
- iii) Canvass connections at the outlet of each fan
- iv) Nuts, bolts, shims etc. as required for the grouting of the equipment
- v) Float valves in the air washer tank, along with quick fill connection

15.9.5 **LIMITATIONS:**

The air velocity limits are as follows:

- i) Average velocity across air washer filters shall not exceed 2.5 m/sec (500 FPM)
- ii) Velocity at blower outlet shall not exceed 10 m/sec (2000 FPM)

15.10 SCRUBBER

15.10.1 **GENERAL:**

The kitchen Scrubber will be self-contained and will consist of the following component parts listed in the following paragraph. The entire unit shall be weather proofed and corrosion protected as herein after specified. The unit shall be factory fabricated and will include:

15.10.2 **BLOWER SECTION:**

The blower section shall be constructed out of 16G GI sheet in folded construction and shall include Centrifugal backward curved DIDW fan wheel of totally GI construction with inlet cones and shall be complete with individual motor and drive and shall be mounted C Channel frame and Cushy Foot or Spring Mounts. The fan shall have a capacity not less than the one specified in the catalogues and shall be constructed and rated based on delivery against the

rated static pressure with the media and filters in place. The fan will be of riveted construction and made with GI sheet of required thickness. The fan wheel will be of the multi-blade type and mounted on two self-aligning pillow block bearings of the requisite size. The fan shall be run with the help of groove drives as per the recommendation of the drive supplier. The blower housing will be of the Pittsburg joint construction and the drive will be provided by a motor of adequate capacity. The motor plate will be constructed out of 6mm MS or heavier metal with slotted holes, which permit belt adjustment in both the direction. The outlet velocity of the blowers will be kept low.

15.10.3 EVAPORATIVE/ SCRUBBER SECTION:

The wet section will have 16G GI tank and body with folded construction with the bolted openable sides also in 18G SS sheet/FRP. The wet section will contain 50 mm thick rigid media to act as the first stage of scrubber to be sprayed by water through WIDE ANGLE NOZZLES to wet, scrub and clean the media installed at the inlet. These nozzles will be provided on a pipe grid such that the total face of the first bank of rigid media is kept fully wet and also gets pressure cleaning.

The wet section will have a also have another subsequent layer of 150 mm thick rigid media which will act as the cleaning media for the smoke and smell, these media banks will be designed @ 2.5 m/s to give 90% adiabatic efficiency. For the second bank 2 mm thick FRP specially fabricated header will be provided for the water distribution using perforated PVC piping 15 mm brass bleed off cock along with 20 mm heavy duty brass float. PVC drain/overflow and bleed off outlet are to be provided on all wet sections.

15.10.4 FILTER SECTION:

All wet sections will include 5 layer 30 micron aluminium wire mesh filters of 50 mm thickness including the mounting channels in SS 304 1.6mm GI for ease of removal and renewal of filter cells. The filters to be designed at 2.5 m/s to give 90% efficiency down to 30 microns.

15.10.5 PUMPS

The unit will have a horizontal single phase 220 Volts + 6% 50 c/s single phase power supply mono block self priming pump assembly to provide recirculated tank water and a pressurized flow via a piping system for proper pad and media water distribution. The pump capacity will be such that it can take care of the bank of nozzles provided for cleaning the first bank and also feed water to wet the second bank.

15.10.6 CABINET FANS

The construction of the cabinet fans shall be identical with that of the air washer unit except that the cabinet fans will not have filters and humidifiers

15.11 PAINTING

All equipment shall be supplied with the manufacturer's standard finished painting.

CHAPTER - 16

COLD ROOMS

16.1 SCOPE

This chapter describes cold rooms with factory assembled Dx-type refrigeration unit, product cooler and defrosting & reheat arrangement required for cold room work. For system design para 2.4 may be referred.

16.2 COMPRESSOR

The compressor shall be multicylinder , reciprocating open/ hermetic/ semi hermetic type. The compressor shall be complete with crank case heaters, forced feed lubrication system, isolation valves strainer, safety controls, interlocking, instruments etc. as are required for efficient and safe operation of the unit.

16.3 DRIVE ARRANGEMENT

The Compressor shall be direct driven. It shall be complete with a guard.

16.4 MOTOR

The electric motor driving the compressor for open type unit shall be squirrel cage fan cooled, induction motor having drip proof enclosure and class 'B' insulation where as for sealed units, it shall be totally enclosed type.

The motor shall be suitable for operation on 415 volts 3 phase 50 Hz supply. The motor HP shall be at least 110% of the maximum power requirement of the compressor. The motor shall be provided with bank of capacitors for power factor improvement with motors of 5 HP & above. The motor starter shall be as per para 13.9.

16.5 CONDENSER

The condenser shall be shell & tube type, water cooled and shall match the compressor capacity. The condenser shall be selected for 4.2 deg C temperature rise of water (water in 32.2 deg C and water out 36.4. deg C). The condensing temperature shall not exceed 40 deg C. The total heat rejection shall be calculated based on evaporator temperature and condensing temperature. The condenser shall be designed for fouling factor of 0.0002 (metric). The condenser shall have integrally finned copper tubes and thickness at the root of fins shall not be less than 0.63mm. The minimum tube thickness of copper tubes shall be not less than 1.0mm. The water velocity in tube shall not exceed 3 m/s and pressure drop in condenser shall not exceed 8 m of water.

The condenser shall be complete with all connections, isolating valves, water inlet & outlet connections with thermometers & pressure gauges, globe valve on water out let, flow switch in water line.

16.6 PRODUCT COOLER

The product cooler shall be factory assembled ceiling/ wall mounted and shall consist of direct expansion cooling coil, hot water coil for defrosting, hot water coil for reheat (if required), propeller fan with motor. The cabinet shall be of 1.6 mm G.I. sheet on rigid frame. The drain pan shall be insulated and large enough to prevent any dripping of the condensate. The drain pan shall have adequate slope to ensure efficient drainage of defrosted condensate. The drain pan & drain pipe shall be provided with insulated heating element to prevent frosting.

The cooling coil shall be with copper tubes & copper fins. The tube thickness shall not be less than 0.5mm. The hot water coils for defrosting and re-heating shall also be with copper tubes and copper fins. The tubes & interconnecting pipe shall be designed in such a manner that water does not remain trapped inside the cold rooms when water circulation is stopped. Suitable manual heating arrangement may also be provided to clear the tubes of any accidental frosting inside.

The fan shall be statically and dynamically balanced, medium speed preferably direct driven by a suitable HP TEFC squirrel cage induction motor complete with starter. The motor shall be specially insulated to withstand saturated conditions and suitable for operation on specified inside temperatures.

16.7 REFRIGERATION PIPING:

The compressor, condenser & product cooler shall be interconnected with 'L' . Type copper refrigerant pipe of suitable size. Isolation , valves shall be provided with compressor, condenser & product cooler etc. Interconnection of refrigerant lines of both the systems shall also be provided.

Suitable number of expansion valves shall be provided for achieving temperature, control. The refrigerant line shall be complete including liquid flow indicator/ drier with by pass arrangement etc. Suction line shall be suitably insulated.

16.8 DEFROSTING & REHEAT ARRANGEMENT

Common hot water generator shall be provided in the equipment room for supplying hot water to the hot water coils in product coolers for defrosting of the D.-X. coil and reheat for dehumidification purpose. Insulated pipe line along with pump, control valves etc. shall be provided for each product cooler separately. In place of plaster aluminium foil cladding shall be provided over insulation. The hot water generator shall be capable to meet the maximum requirement of hot water of both the cold rooms simultaneously. All valves/ controls for the same should be provided out side the cold rooms. Arrangement for make up water in the hot water generator with the help of level controller shall be made. The heating element shall also be interlocked with the level in the hot water generator. Thermostat, shall be provided to maintain the hot water temperature within limits. Safety provisions shall be as per para 2.4.3.

16.9 PAINTING

All equipment shall be supplied with the manufacturer's standard finished painting.

CHAPTER-17

INSPECTION, TESTING AND COMMISSIONING

17.1 SCOPE

This chapter covers initial inspection and testing of compressor, condenser, chiller & AHUs at manufacturer's works, initial inspection of other equipments/ materials on receipt at site, final inspection testing & commissioning of all equipment at site & description of testing requirements & procedure.

17.2 INITIAL INSPECTION AT MANUFACTURER'S WORKS

17.2.1 Centrifugal / Screw Compressor

- i) Salient features such as model, capacity control, type of lubrication etc. shall be verified against the requirements visually without opening the compressors.
- ii) Manufacturer's internal test certificates shall be scrutinised to check compliance with the requirements as specified in the contract.
- iii) Free running test shall be carried out at the speed for which the motor is available with manufacturer but the speed shall not be less than that specified in contract. This test shall be carried out for 30 minutes in open space. During this running test following operations are to be noted :
 - a. Manual operation of capacity control
 - b. Lubrication oil pressure
- iv)
 - a. Pneumatic test pressure test at 21 Kgf/sq.cm for casing of compressor.
 - b. Vacuum test for the compressor for 0.5mm of Hg.

17.2.2 Reciprocating compressor

- i) Salient features such as model, No. of cylinders, capacity control, provision of crank case heaters, type of lubrication etc. shall be verified against the requirements visually without opening the compressors.
- ii) Manufacturer's internal test certificates shall be scrutinised to check compliance with the requirements as specified in the order.
- iii) Rate of leak test shall be checked by developing 7kg/sq.cm (gauge) pressure on HP side and 1 kg/ sq.cm on LP side using dry Nitrogen air or carbon dioxide. The leakage through the valves, shaft seal, cylinder heat gasket etc should not be more than 0.3 kg/sq.cm per cylinder in 4 minutes time. Alternatively this may be demonstrated through vacuum.
- iv) Pneumatic pressure test shall be carried out at 22 kg/ sq.cm and by submerging the compressor in water for 1 hour & there shall be no leakage.

- v) Free running test shall be carried out at the rated speed specified in contract. This test shall be carried out for 30 minutes in open space. During this running test following operations are to be noted :
 - a. Manual loading / unloading of capacity control
 - b. Lubrication oil pressure
 - c. Safety valve operation
- vi) Vacuum test for the compressor for 0.5mm Hg.

17.2.3 Condenser

- i) Salient features like number of tubes, inside diameter of tubes (from which the gauge of the tube can be verified), no. of passes, material of fins, length of condenser, provision of fittings like safety valve, water, gas connection shall be verified during stage inspection. The tube thickness shall be checked.
- ii) Manufacturer's internal test certificates shall be furnished and it shall be verified against contract requirements.
- iii) Pneumatic pressure test at twice the normal condensing pressure for gas side of condenser shall be carried out.
- iv) Hydraulic test at 10 Kgf/ sq.cm. for water side of the condenser shall be carried out.

17.2.4 Chiller

- i) Salient features like type of chiller, number and inside diameter of tubes (from which gauge of the tubes can be verified), material of tubes, type, material and the number of fins, wherever applicable, diameter and length of chiller and provision of fittings be verified against requirements specified in the contract during stage inspection. Tube thickness shall be checked.
- ii) Manufacturer's internal test certificate shall be furnished and same shall be checked as per contract requirements.
- iii) Pneumatic pressure test at twice the normal condensing pressure for gas side of condenser shall be carried out.
- iv) Hydraulic test at 10 Kgf/sq.cm. for the water side of chiller shall be carried out.

17.2.5 Chilling unit (Water cooled only)

Full load test shall be carried out to verify the capacity and IKW / Ton. (For air cooled chilling units this test shall be carried out at site)

Note: In case of imported centrifugal chilling machine, initial inspection shall be carried out at site before installation in respect of items needing physical inspection and verification. The test certificates for all the specified tests shall be produced which shall be accepted if found in order.

Factory Testing:

The complete unit shall be factory tested at 25%, 50%, 75% and 100% capacity at constant condenser water temperature and witnessed by *Representatives of the Department or as given in bid document* for performance at the rated conditions by simulating the actual design conditions. One unit of each capacity shall be tested.

All controls and switchgear shall be tested for proper functioning and set of design values.

The capacity in TR / kcal/hr shall be calculated from measurements of temperature difference and flow rate of water, in condenser and chiller. The power consumption shall be checked from current measurement of the motor. All calculated and checked results shall match the specified data within tolerances as stipulated by ARI.

All instruments and personnel for tests shall be provided by the contractor. Contractor shall inform the client about the chiller testing schedule min. 10 to 15 days before the chiller is ready for factory testing.

17.2.6 Air Handling Units :

- i) Salient features such as model, size, physical dimensions, and other details of various sections, fan motor details, fan dia, static pressure etc. shall be verified against the contract requirements.
- ii) Manufacturer's internal test certificates for the motor and air handling unit shall be furnished and scrutinized as per contract requirements.
- iii) Test certificate for static and dynamic balancing of the fan/ blower should be furnished. Fan balancing may be witnessed by Engineer-in-Charge or his authorised representative.
- iv) Salient features like, type, material, no. and gauge of fins and tubes and no. of rows of cooling coil shall be furnished and verified with reference to contract requirements during stage inspection.
- v) Hydraulic pressure to the extent of 10 Kgf/sq.cm or pneumatic pressure of 21 kgf/ sq.cm shall be applied to cooling coil and this pressure should be maintained for 1 hour and no drop should be observed indicating any leaks.

17.3 INITIAL INSPECTION AT SITE

17.3.1 Ducting:

- i) The sheet used for ducting shall be checked for physical test at site. The physical test should include the sheet thickness and bend test as per relevant IS specifications.
- ii) Zinc coating of GSS sheet as mentioned in the tender documents may be got tested from a laboratory to verify that same meets the contract requirements.

17.3.2 Pumps:

- i) Salient features such as model and make shall be checked as per contract requirements.
- ii) The manufacturer's test certificates with Sr. No., head, discharge will be furnished and verified against contract requirements.

17.3.3 Cooling tower

- i) Salient features such as make, model, dimensions, materials used, constructional details, number and size of nozzles, headers, size of tank, etc. should be verified against the requirements. Inspection of cooling tower in knocked down condition would be carried out at the site.
- ii) Manufacturer's test certificate certifying the capacity of cooling tower and static balancing of fan should be furnished.

17.3.4 Switch Gear, Control Gear, and Measuring Instruments

These should be of specified make. For air circuit breaker manufacturer's test certificate shall be furnished by contractor and the same shall be verified as per contract requirements.

17.3.5 Electric Motors

Electric motors should be of specified make, manufacturer's test certificate for electric motor shall be furnished.

17.3.6 Pipes and Valves

- i) It should be checked that the same is as per makes specified in contract.
- ii) Dimensions including weight shall be checked for pipes against the requirements of contract.
- iii) **Manufacturer's test certificates for valves for testing of pressure withstand .**

17.3.7 Insulation and acoustic lining

- i) Physical verification for thickness and make should be made as per contract before application of insulation.
- ii) Manufacturer's test certificate for density , **thermal conductivity , sound absorption and class of fire retardation wherever applicable** should be furnished.

Note: Accuracy of testing instruments shall be as mentioned in the final inspection procedure.

17.4 FINAL INSPECTION

- i) After completion of the entire installation as per specification in all respects, the AC contractor shall demonstrate trouble free running of the AC equipments and installation for a period of minimum 120 hours of running as detailed under para 1.15.
- ii) After the trial run as in para 1.15 above, the AC contractor shall offer the plant for the seasonal test, namely test for summer or monsoon season whichever occurs earlier. The test results as per Appendix G shall be furnished.
- iii) The equipment capacity computations as per para `B` under notes of the Annexure `G` shall be carried out.
- iv) The Input KW of the unit / TR at full load shall also be checked against contract requirements, if any.
- v) Pressure drops across chiller and condenser at specified flow rates shall be checked against the contract requirements.
- vi) All instruments for testing shall be provided by the AC contractor . These shall be as per Note `A` of Appendix G. The accuracy of the instruments shall be as follows:
 - a. Temperature: Liquid in glass thermometer having accuracy ± 1 deg. C as per IS: 4825.
 - b. Wet bulb Temperature : Sling psychrometer conforming to IS:6017.

Scale Error:
For less than 0 deg. C : 0.3 deg C \pm 0.2 deg. C.
For over 0 deg. C : 0.2 deg. C \pm 0.1 deg. C.
 - c. Pressure Gauge: With the accuracy of $\pm 1\%$ for maximum scale value from 10 to 90%, and $\pm 1.9\%$ for maximum scale value for rest of the scale conforming to IS: 3695.
 - d. Water flow meter : Water flow shall be measured using the arrangement installed as per schedule of work.

In case the tendering firms do not have testing instruments of the accuracy mentioned above, they should specify the accuracy of the instrument available with them for testing at the tender stage.

17.5 TESTING REQUIREMENTS AND PROCEDURES

- 17.5.1 Balancing of all air and water systems and all tests as called for in the specification shall be carried out by the HVAC contractor in accordance with the specifications and relevant local codes if any. Performance tests of individual equipment and control shall be carried out as per manufacturer's

recommendation. All tests and balancing shall be carried out in the presence of Engineer-in-charge or his authorized representative.

The whole system balancing shall be tested with microprocessor based hi-tech instruments with an accuracy $\pm 0.5\%$.

The instrument shall be capable of storing data and then down loading into a P.C. The HVAC contractor shall provide a minimum but not limited to the following instruments:

- i) Microprocessor based calculation meter to measure DB and WB temperature, RH and Dew point
- ii) Velo meter to measure air volume and air velocity
- iii) Pitot tube
- iv) Electronic rotary vane Anemometer
- v) Accubalance flow measuring hood

The contractor shall be responsible to provide necessary sockets and connections for fixing of the testing instruments, probes etc.

17.5.2 Air Systems:

Systems are to be balanced by first adjusting the total flow at the fan, then by adjusting main dampers and branch dampers. Only final minor adjustments are to be made with register and diffuser dampers. Balancing of the air system shall be accomplished without causing objectionable air noise. Baffles and orifice plates required for proper air balance shall be furnished and installed by the contractor. Basically the following tests and adjustments are required.

- i) Test all fan systems to provide proper cfm/ cmh.
- ii) Adjust fresh air, return air and exhaust dampers to provide proper air quantities in all modes of control.
- iii) Test and record fresh air, return air and mixed air temperature at all air handling units. Test and record data at all coils after air and hydronic systems are balanced. Measure wet and dry bulb temperature on cooling coils.
- iv) Make point tube transverse at all main supply and return ducts to set proper air quantities. Adjust all zone and branch dampers to proper cfm/cmh.
- v) Test and adjust each register, grills, diffuser or other terminals equipment to within 5% of design air quantity. Each opening shall be defined on the test report by size, manufacturer's model, room location, design cfm and actual cfm. Outlets shall be adjusted to minimize objectionable drafts.
- vi) Test and record static pressure drop across all filters and major coils.
- vii) High velocity duct systems shall be tested for leakage. If excessive or audible leakage is detected, the defect shall be repaired by the contractor. Sufficient static pressure readings shall be taken from the air handling units to the terminal units to establish system static pressure.

17.5.3 Water System:

Systems are to be balanced by opening all valves, closing all by-pass and setting all mixing valves to full coil flow. Water systems shall be cleared of air. Verify that the system has been properly cleaned, flushed and treated before testing. Basically, the following tests and adjustments are required.

- i) Test and adjust all pumps to deliver the proper gpm. Record rpm, motor amperage, discharge and suction pressure. Pumps shall operate without objectionable noise or cavitation. Plot actual pump and system performance points on manufacturer's pump curves.
- ii) Check all expansion tanks for proper filling pressurization. Verify operation of automatic fill and relief valves.
- iii) Check the operation of all automatic valves.
- iv) Test and adjust correct water flow through chiller, major items of equipment and main water circuits. The balancing valves, provided on the equipment shall be used for adjustment.
- v) Check capacity output of chillers and set water flow rate for proper data.
- vi) Check and adjust each coil to provide proper gpm. Record water and air temperature changes and water pressure drop.
- vii) Set pressure drops across coil by-pass to match coil full-flow pressure drop.

17.5.4 Unit capacity in Tons Refrigeration shall be computed from the temperature readings, pressure readings and water/ brine flow measurements. Flow measurements shall be preferably through flow meters. Pumps shall be tested for the discharge head, flow and BHP. Where it is not possible to measure the flow, atleast the discharge head and BHP (on the input side) shall be field tested.

17.5.5 Balancing Tolerance:

Systems shall be balanced within the following tolerances ;

- i) Duct leakage Rates (at operating pressures) :

Low pressure ducts (0 to 0.5 kPa)	5% of full flow
Medium Pressure Ducts (0.5 to 3 kPa)	1% of full flow
High Pressure Ducts (Greater than 3 kPa)	1% of full flow
- ii) Air flow rates :

Under 70 L/S	10% of flow
Over/ at 70 L/S	5% of flow
- iii) Water flow rates :

Chilled Water	2% of flow
Other	5% of flow
- iv) Heat flow rates :

Heat exchangers	5% of design capacity
-----------------	-----------------------

Procedure:

Review all pertinent plans, specifications, shop drawings and other documentation to become fully familiar with the systems and their specified and intended performance.

Furnish equipment and instruct sheet metal trade on proper use for conducting duct leakage tests. Conduct first test as a way of instructing the above trades in the presence of the Department's representative.

Test relative barometric pressures in various building area, as deemed necessary by the Department's representative and at least in all areas served by different systems.

Test performance and continuously record on a 24 hour basis, temperature and humidity levels where control equipment is provided for that purpose in certain critical areas.

Before commissioning of the equipment, the entire electrical installation shall be tested in accordance with relevant BIS codes and test report shall be furnished by a qualified and authorised person.

17.5.6 Reports

Provide 3 copies of the complete balancing and testing reports to the department. Report shall be neatly typed and bound suitable for a permanent record. Report forms shall contain complete test data and equipment data as specified and safety measures provided as per para 1.14.3.

17.5.7 Final documentation

The contractor shall leave the system operating in complete balance with water and air quantities as shown on drawings. Set stops on all balancing valves and lock all damper quadrants in proper position. Secure all automatic damper and valve linkages in proper positions to provide correct operating ranges. Proper damper positions shall be marked on ducts with permanent indication. Notify the department of any areas marginal or unacceptable system performance.

The above tests and procedures are mentioned herein, for general guidance and information only, but not by way of lamination to the provisions of conditions of contract and design/ performance criteria.

Upon commissioning and final handover of the installation, the HVAC contractor shall submit (within 4 weeks) to the engineer-in-charge/ department 6 (six) portfolios of the following indexed and bound together in hard cover ring binder (300 x 450 mm) in addition to the completion drawings as per para 1.18.3.

- i) Comprehensive operation and maintenance manual
- ii) Test certificates, consolidated control diagram and technical literature on all controls.
- iii) Equipment warranties from manufacturers.
- iv) Commissioning and testing reports
- v) Rating charts for all equipment
- vi) Log books as per equipment manufacturers standard format
- vii) List of recommended spares and consumables

- viii) Any special tools required for the operation or the maintenance of the plant shall be supplied free with the plant.

At the close of the work and before issue of final certificate of completion by the Engineer-in-charge, the contractor shall furnish a written guarantee indemnifying the department against defective materials and workmanship for the Defects liability period. The contractor shall hold himself fully responsible for reinstallation or replace free of cost to the department.

- i) Any defective material or equipment supplied by the contractor
- ii) Any material or equipment supplied by the department which is proved to be damaged or destroyed as a result of defective workmanship by the contractor.

CHAPTER-18

BUILDING MANAGEMENT SYSTEM

18.1 SCOPE

The Building Management System (BMS) to be provided shall perform the following general functions:

- i) Building Management and Control
- ii) Monitoring and Control of Controllers, Remote Devices and Programmable Logic Controllers
- iii) Operator Interface
- iv) Video display integration
- v) Data collection, Historization , Alarm Management & Trending
- vi) Report Generation
- vii) Network Integration
- viii) Data exchange and integration with a diverse range of other computing and facilities systems using industry standard techniques.

The scope of BMS here is for Air-conditioning applications only. It should be expanded type to connect it with other building services in future. The BMS software and supervising should have the capability to expand the system at least upto 50% of the present capability.

18.2 SYSTEM ARCHITECTURE

The system offered shall be completely modular in structure and freely expandable at any stage with 3 level architecture

- i) The Management Level
- ii) The Automation Level
- iii) The Field Level

Each level of the system shall operate independently of the next level up.

The system shall fully be consistent with the latest industry standards, operating on Windows 2000 or Windows NT or later, allowing the user to make full use of the features provided with these operating systems.

To provide maximum flexibility and to respond to changes in the building use, the system offered shall support the use of BACnet, LON, Profibus and Ethernet TCP/IP communication technologies.

All plant and equipment requiring control and / or monitoring functions shall be fitted with all necessary interfacing equipment readable by the BMS network.

18.2.1 The Management Level

The management level and operation of the plant shall include process visualization, data analysis, and exchange of data. At the management level, it shall be possible for communication to flow in all directions, across networks and via direct connections. The management level of the system shall consist of one and shall be capable of handling more management station PCs and the associated software modules. The total number of management station PCs shall be as described elsewhere in the specifications.

18.2.2 The Automation Level

The level at which the actual processing takes place based on the logic written on the DDC. The processes are carried out at the DDC controllers for stand-alone control of all plant.

18.2.3 The Field Level

Individual room controllers for autonomous room – by – room comfort control, based on application specific logic written on the controllers.

18.3 INTERFACE AND INTEGRATION

18.3.1 Maintenance Management

i) Integrated

The system shall provide an integrated Maintenance Management function. The Maintenance Management function shall use specified breakdown alarms, equipment run hours or analog values from the BMS.

ii) Third Party

The system shall be capable of integrating with external maintenance systems such as MS Excel, MS Access. This integration shall consist of transferring specified breakdown alarms and equipment run hours from the BMS to the external maintenance system.

18.4 DIGITAL CONTROLLERS

18.4.1 General

Digital Control Processors / Direct Digital Controller (DDC) shall be as specified with capacity to accommodate input/ output (I/O) points required for the application plus spare points specified.

Each DDC will be a truly standalone controller with its own Input-Output capacity, control logic capability, time programming and energy management capabilities. All field equipment including the sensing element (inputs) and control elements (outputs) would be wired to the respective DDC. It shall be possible to hook up a DDC to a Portable Operator Terminal (POT) to enable monitoring and control of the DDC.

DDC shall be designed for complex DDC and energy management applications, true peer-to-peer communications with other DDC and with the Central Operator Stations. The DDC will be networked on a truly distributed intelligence concept where each DDC shall be a self-sustained intelligent device capable of all its functionality's without dependence on other devices

18.4.2 DDC Hardware:

- i) Digital Control Processors (DDC) shall be 16 bit microprocessor types with Electrical Erasable Program Read Only Memory (EEPROM) based Operating System (OS) and shall use EEPROM or flash memory for all data file and control programs (DDC Programs) and using RAM only for operating data.
- ii) Each DDC shall have Nickel cadmium Lithium battery to support complete operation of the RAM for upto 30 days in the event of a power failure to the DDC. A low battery voltage status will generate an alarm condition.
- iii) DDC shall have internal real-time clocks with 30-day battery backup power. All time-based controls (time scheduling, integrations and other real-time based controls) shall be performed with this real-time resident clock. Clock synchronization of the DDC on the whole bus will be automatic

DDC using clocks generated by software or timers for clocking shall not be accepted.
- iv) The battery backup power shall support the real-time clock. Upon power restoration all clocks shall synchronize automatically.
- v) The DDC's shall be capable of supporting 8 to 48 I/Os preferably in a combination of 8 AI (Analog input), 2 DI(Digital input), 4 AO(Analog output), 2 DO(Digital output) with minimum of 10% spares of each type per DDC.
- vi) The DDC would be dedicated standalone in nature and would be placed near the instrument they are controlling to reduce the installation and wiring cost.
- vii) Analogue input support of the following minimum types shall be provided:
0/4-20mA
0-10 volts
0-5 volts
0/2-10 volts
Resistance signals (Pt3000, Pt1000, Pt100, Ni1000)
- viii) Digital Inputs type shall be, but not limited to the following types:
Normally open discrete contacts
Normally closed discrete contacts

18.4.3 DDC POT functionality shall be as follows:

- i) There will be an electrical socket/port in every DDC for accessing the data points and real time information via a portable plug-in type Portable Operator Terminal (POT).
 - a) The POT shall not have any EEPROM and shall not require any programming.
 - b) The POT will plug into the DDC for its power and data. The POT which are not plugged in to the DDC but are hard wired from the

Interface unit, PC station or any other device shall not be acceptable.

- ii) The connection of the POT to a controller shall not affect normal operation of the controller or the bus communication in any way.
- iii) The connection of the POT to any controller on a bus shall provide display access to all controllers on the bus. Each DDC shall have provision for plugging of the POT.
- iv) It shall be possible for the POT to be connected to any controller on the bus to view and control any point on any other controller on the bus under password protected menus. POTs in which only a predefined number & set of points are available shall not be accepted.
- v) A failure of any DDC on the bus, Interface unit or Central PC station or any other device of the system shall not affect the operation of the POT.

Systems in which the POT is connected to only a single interface master port and hard wired to other controllers are not acceptable.

- vi) Use of a POT at DDC shall allow the user to display software information and via password control, modify DDC software.
- vii) All displays on the POT shall be in English language text and data points shall have customised descriptions as per application requirement.
- viii) The POT shall be equipped with a multiple lines (with minimum of 4 lines of 20 characters each) backlit alphanumeric LCD display and a control keypad. The keypad would include Command keys, data entry keys and cursor control keys
- ix) Access shall be through self-prompting menus with cursor controls for moving through the menus. Menu selection would be with arrow key controls for moving to next/previous menu and to step forward backward within a menu

18.5 FIELD DEVICES

18.5.1 Electronic Data Inputs and Outputs

Input/output sensors and devices shall be matched to the requirements of the respective connected controller panel for accurate, noise-free signal input/output. Control input response shall be high sensitivity and matched to the loop gain requirements for precise and responsive control.

18.5.1.1 Temperature Sensors

Temperature sensors shall be Resistance Temperature Detector types of Pt3000, Pt1000, Pt100 or Ni1000. These shall be two wire type sensors and shall conform to following:

- i) Space temperature sensors shall be wall/surface mounted and shall be provided with blank commercial type looking covers
- ii) Duct temperature sensors shall be rigid stem or averaging type as specified and shall be suitable for duct installation
- iii) Immersion temperature sensors shall be provided with matching Stainless steel thermo- well of lengths as specified.
- iv) Outdoor air temperature sensors shall have weatherproof enclosures and shall be directly wall/surface mounted
- v) Outside air, return air, discharge air, return air, space and well sensors shall have ± 0.55 degrees C accuracy between 0 degree and 100 degree C.

18.5.1.2 Relative Humidity Sensors :

- i) Relative humidity sensors shall be capacitance type with an effective sensing range of 10% to 90% .
- ii) Accuracy shall be +/-5% or better
- iii) Duct mounted humidity sensors shall be provided with a sampling chamber. Wall mounted sensors shall be provided with covers identical to temperature sensors. Sensor housing shall plug into the base such that the same can be easily removed without disturbing the wiring.

18.5.1.3 Differential and Static Pressure Switches

A. Differential pressure switches-air :

- i) They shall have field adjustable set-point capability for the specified range.
- ii) They shall provide a built-in switching differential at the set-point over the specified range.
- iii) Switches shall be piped to fan discharge except where fans operate at less than 25mm WC(water column), they shall be piped across the fan.
- iv) Maximum pressure rating shall be at least 300 mm WC.
- v) The electrical contacts shall provide dry contacts as specified and shall be rated for at least 300V A pilot duty @ 240V AC

B) Differential pressure switches-water :

- i) Switches shall be adjustable differential pressure type as specified in the sequence of operation or data point summary.
- ii) Devices shall be 10 kg/ sq.cm rated except chilled water flow switches shall be provided with totally sealed vapor tight switch enclosure on 20 kg/sq.cm body.
- iii) Differential pressure switches shall have valved manifold for servicing.
- iv) The electrical contacts shall provide dry contacts as specified and shall be rated for at least 300V A pilot duty @ 240V AC.

18.5.1.4 Differential Pressure Sensors

A) Air Flow / Pressure sensors

- i) Air flow and duct static pressure analog sensors shall be high accuracy suitable for the low pressures to be encountered, be selected for approximately 50% over range, and have a 4 to 20 ma/ 0-10 VDC output.
 - ii) Air flow measuring station sensors shall be with valved lines for testing and calibration, and shall have adjustments for zero and span.
 - B) Water flow Sensors
 - i) Water flow analog sensors shall be provided complete with flow element and shall be an all solid state precision industrial type with stainless-steel body, maximum error of not more than 0.5% of span.
 - ii) Sensor shall be rated for 17 kg/sq.cm minimum and installed in strict accordance to the manufacturer's instructions complete with three-valve manifold for calibration and maintenance.
- 18.5.1.5 Water Hardness Analyser
- i) The water hardness analyzer shall be on-line conductivity type and shall provide analog output proportional to specified range.
 - ii) Control relays and analog output transducers shall be compatible with controller output signals. Relays shall be suitable for the loads encountered. Analog output transducers shall be designed for precision closed loop control with pneumatic repeatability error no greater than 2%.
- 18.5.1.6 Level Measurement
- A) Level Switches
 - i) Level switches shall be directly vessel mounted type either top mounted or side mounted as required.
 - ii) These shall be float type unless specified. Process connection shall be flanged. Wetted parts shall be made of stainless steel (SS316).
 - B) Level Sensors
 - i) Level sensors shall be capacitance probe type.
 - ii) It shall be possible to mount the transmitter unit integral to the probe on the vessel or field mounted away from the probe
 - iii) Unless specified probe insulation shall be of PTFE and probe rod material SS316
 - iv) Process connection shall be flanged or BSP connections as specified.
- 18.5.2 Automatic Control Valves
- i) Automatic control valves upto 50mm and smaller shall be screwed type, and valves of 65 mm and larger shall be flanged type.
 - ii) Valves shall be ANSI-rated to withstand the pressures and temperatures encountered. Valves shall have stainless-steel stems and spring loaded Teflon packaging with replaceable discs .
 - iii) All modulating straight-through water valves shall be provided with equal-percentage contoured throttling plugs. All three-way valves shall be provided with linear throttling plugs such that the total flow through the valve shall remain constant regardless of the valve's position.

- iv) Valves shall be sized as specified for a pressure drop equal to the coil they serve but not to exceed 0.2 kg/ sq.cm.
- v) All modulating steam valves shall have linear characteristic for 90% of the closing stroke and equal-percentage for the final 10%. Valves shall be sized for 0.68kg/ sq.cm entering steam and 0.2 kg/ sq.cm pressure drop through valves.
- vi) All automatic control valves shall be actuated by a directly coupled proportional electric actuator. Eccentric linkages are not acceptable.

18.5.3 Electric Actuators for Valves and Dampers

- i) Unless specified, the electric actuator shall accept proportional input signal of 0/2- 10VDC or 0/4-20mA. Unless specified actuators shall provide modulating control. Actuators shall be powered 24VAC or 240VAC as specified.
- ii) The actuators shall be designed to deliver the required torque and have close off pressure ratings as required by the specified process data
- iii) The actuator shall incorporate magnetic coupling to ensure torque limitation which shall be independent of voltage supply.
- iv) Unless specified, in case of power failure the actuator shaft position will remain stay-put at the last position just before power off.
- v) It shall be possible to replace the actuator / remove the actuator / dismantle it from the valve body without having to remove the valve body.
- vi) The actuator shall have a built in electronic switch to enable switch-over of direct / reverse action of valve/damper. It shall be possible to change the direct/reverse action of valve without having to remove the actuator from valve body or change linkage assemblies.

18.6 BMS I-O (Input-Output) Summary

Table-1 gives Input-Output summary for a typical BMS application involving 1 no. chilling unit, 2 nos. primary chilled water pumps, 4 nos. secondary chilled water pumps, 2 nos. condenser water pumps, 2 nos. cooling towers & 12 nos. AHUs.

TABLE-1

BMS I-O (Input - Output) Summary

S. No.	Description	Point Functions								Filed devices	Type of I/O
		AI	DI	AO	DO	Mon-itor	Cont-rol	Ala- rm			
A	HVAC Equipment										
	HIGH SIDE										
1.	Chilling Machines										
a.	Chiller On/ OFF				1		X			Relay Contact	Potential Free contact in Chiller Panel
b.	Chiller Run Status		1			X		X			Potential Free contact in Chiller Panel
c.	Chiller Auto/ Manual Status		1			X		X			Potential Free contact in Chiller Panel
d.	Chiller-Water Temp Reset			1			X				0-10 VDC signal from chiller panel

e.	Chiller trip/ fault		1			X				Potential Free contact in Chiller Panel
f.	Chiller chilled water supply temp in (1) + out	2				X			Immersion type sensor	Suitable Insertion provision
g.	Ambient Temperature	1				X			Outside air temp. & RH sensor	Suitable Installation Provision
h.	Ambient RH	1				X				Suitable Installation Provision
	Sub Total	4	3	1	1					
2.	<u>Chilled Water Pumps</u>									
a.	Primary Chilled Water Pump On/ OFF				2		X		Relay output	Potential Free contact in Pump Starter Panel
b.	Primary Chilled Water pump run Status		2			X		X		Potential Free contact in Pump Starter Panel
c.	Primary Chilled Water pump flow status		2			X			Differential pressure switch (water)	Suitable Insertion Provision
d.	Secondary CHW Pump On/ Off				4		X		0-10 VDC signal from controller	Potential Free contact in Pump Starter Panel
e.	Secondary CHW pump run Status		4			X		X		Potential Free contact in Pump Starter Panel
f.	Secondary CHW pump flow status		4			X			Differential Pressure Switch (water)	Suitable Insertion Provision
g.	Secondary CHW variable speed control			4						Provision of VFD for pumps
	Sub Total	0	12	4	6					
3.	<u>Condenser Water Pumps</u>									
a.	Condenser pump On/ Off				2		X		Relay output	Potential free contact in starter panel
b.	Cooling tower air flow status		2			X		X	Air flow switch	Suitable Installation provision
c.	Cooling tower sump low water		2			X		X	Low level switch	Suitable Insertion provision
d.	Cooling tower 'IN' valves/ status		2		2	X	X	X	Motorised B/F valves	Suitable Installation provision
e.	Water Temp.	2				X		X	Immersion type sensor	Suitable Insertion provision
f.	Fire signal input					X		X		Potential free contact from the fire panel
	Sub Total	2	6	0	4					

Table-1 contd...

S. No	Description	AI	DI	AO	DO	Monitor	Control	Alarm	Filed devices	Type of I/O
-------	-------------	----	----	----	----	---------	---------	-------	---------------	-------------

B.	LOW SIDE								
1.	Air Handling units								
a.	AHU speed fan On/ Off			12		X		Relay contact	Potential free contact in the AHU panel
b.	AHU air flow status		12			X		Differential Pressure switch	Suitable Insertion provision
c.	AHU filter status		12			X		Differential pressure switch	Suitable Insertion provision
d.	Return Air Temperature	12				X		Duct Temp. Sensor	Suitable Insertion provision
e.	Motorised valve cooling			12			X	2 way motorised valve	Suitable Insertion provision
f.	Fan speed control			12				Variable speed drive	6-10 volt signal to VFD
g.	AHU Auto/ Manual status		12			X			Potential free contact from the fire panel
	Sub Total	12	36	24	12				
	Grand Total	18	57	29	23				

APPENDIX –A TERMINOLOGY

1) Air conditioning

The process of treating air so as to control simultaneously its temperature, humidity, purity, distribution and air movement and pressure to meet the requirements of the conditioned space.

2) Dry-Bulb Temperature

The temperature of air as registered by an ordinary thermometer.

3) Wet-Bulb temperature

The temperature registered by a thermometer whose bulb is covered by a wetted wick and exposed to a current of rapidly moving air.

4) Dew point Temperature

The temperature at which condensation of moisture begins when the air is cooled at same pressure.

5) Humidity

It is the amount of water vapour present in a certain volume of air.

6) Relative Humidity

Ratio of the actual water vapor in the air as compared to the maximum amount of water that may be contained at its dry bulb temperature. When the air is saturated, dry bulb, wet bulb and dewpoint temperatures are all equal.

7) Enthalphy

A thermal property indicating the quantity of heat in the air above an arbitrary datum in kilo joules per kg of dry air (or in Btu per pound of dry air).

8) Psychrometry

Psychrometry is the science involving thermo dynamic properties of moist air and the effect of atmospheric moisture on materials and human comfort. It also includes methods of controlling thermal properties of moist air.

9) Psychrometric Chart

A Psychrometric chart graphically represents the thermodynamic properties of moist air. If two properties are known, all the other properties can be determined with the help of psychrometric chart.

10) Evaporative air cooling

The evaporative air-cooling application is the simultaneous removal of sensible heat and the addition of moisture to the air. The water temperature remains

essentially constant at the wet-bulb temperature of the air. This is a process in which heat is not added or removed from the air.

11) Positive Ventilation

The supply of outside air by means of a mechanical device, such as a fan.

12) Atmospheric Pressure

The pressure of air exerted on the surface of earth by the atmospheric column is called atmospheric pressure. At sea level, the atmospheric or barometric pressure is 760mm column of mercury (29.92 in Hg/ 406.8 inch water column/ 101.325 Kpa).

Generally atmospheric pressure is used as a datum for indicating the system pressures in air-conditioning and accordingly, pressures are mentioned above the atmospheric pressure or below the atmospheric pressure considering the atmospheric pressure to be zero. A 'U' tube manometer will indicate zero pressure when atmospheric pressure is measured.

- 13) Indoor Air Quality (IAQ) Indoor air quality refers to the nature of conditioned air that circulates throughout the space/ area where one works or lives, i.e. the air we breath when we are indoors. IAQ refers not only to comfort which is affected by temperature, humidity and odours but also to harmful biological contaminants and chemicals present in the conditioned space.

Bad Indoor Air Quality can be a serious health hazard. Carbon dioxide (CO₂) has been recognized by ASHRAE as the surrogate ventilation index or the only measurable variable for the indoor air contaminants.

14) Buildings Related Illnesses (BRI)

BRI are attributed directly to the specific air-borne building contaminants like the outbreak of the legionnaire's disease after a convention and sensitivity pneumonitis with prolonged exposure to the indoor environment of the building.

15) Sick Building Syndrome (SBS)

SBS is a term, which is used to describe the presence of acute non-specific symptoms in the majority of people caused by working in buildings with an adverse indoor environment. It could be a cluster of complex irritative symptoms like irritation of the eyes, blackened nose and throat, headaches, dizziness, lethargy, fatigue irritation, wheezing, sinus, congestion, skin rash, sensory discomfort from odours, nausea, etc. These symptoms are usually short-termed and experienced immediately after exposure, and may disappear when one leaves the building.

16) Hydronic Systems

Water systems that convey heat to or from a conditioned space or process with hot or chilled water are frequently called hydronic systems. The water flows through piping that connects a chiller or the water heater to suitable terminal heat transfer units located at the space or process.

17) Water conditioning

Water circulating in a hydronic system may require to be treated to make it suitable for air-conditioning system due to its effect on the economics of air-conditioning plant. Unconditioned water used in air-conditioning system may create problems with equipments such as scale formation, corrosion and organic growth.

18) Water Hardness

Hardness in water is represented by the sum of calcium and magnesium salts in water and may also include aluminium, iron, manganese, zinc, etc. A chemical analysis of water sample should provide number of total dissolved solids (TDS) in a water sample in parts per million (ppm) as also composition of each of the salts in parts per million.

Temporary hardness is attributed to carbonates and bi-carbonates of calcium and/or magnesium expressed in parts per million (ppm) as CaCO_3 . The remainder of the hardness is known as permanent hardness, which is due to sulfates, chloride, nitrites of calcium and/or magnesium expressed in ppm as CaCO_3 .

Temporary hardness is primarily responsible for scale formation, which results in poor heat transfer resulting in increased cost of energy for refrigeration and air-conditioning. Permanent hardness (non-carbonate) is not a serious a factor in water conditioning because it has a solubility which is approximately 70 times greater than the carbonate hardness. In many cases, water may contain as much as 1200 ppm of non-carbonate hardness and not deposit a calcium sulfate scale.

The treated water where hardness as ppm of CaCO_3 is reduced to 50 ppm or below, is recommended for air-conditioning applications.

19) Thermal Transmittance

Thermal transmission through unit area of the given building unit divided by the temperature difference between the air or some other fluid on either side of the building unit in 'steady state' conditions.

20) Thermal Energy Storage

Storage of 'Cold Energy' sensible, latent or combination for use in central system for air-conditioning or refrigeration is called thermal energy storage. It uses a primary source of refrigeration for cooling and storing 'Cold Energy' for reuse at peak demand or for backup as planned.

21) Shade factor

The ratio of instantaneous heat gain through the shading device to that through a plain glass sheet of 3mm thickness.

22) Sensible heat factor (SHF)

Sensible heat factor is the ratio of sensible heat to total heat, where total heat is the sum of sensible and latent heat.

23) Supply Air

The air that has been passed through the conditioning apparatus and taken through the duct system and distributed in the conditioned space is termed as supply air.

24) Return Air

The air that is collected from the conditioned space and returned to the conditioning equipment is termed as return air.

25) Re-Circulated Air

The return air that has been passed through the conditioning apparatus before being re-supplied to the space is called re-circulated air.

26) Duct system

A continuous passageway for the transmission of air which in addition to the ducts, may include duct fittings, dampers, plenums and grilles & diffusers.

27) Plenum

An air compartment or chamber to which one or more ducts are connected and which forms part of an distribution system.

28) Supply and Return Air grilles & Diffusers

Grilles and diffusers are the devices fixed in the air-conditioned space for distribution of conditioned supply air and return of air collected from the conditioned space for re-circulation.

29) Fire damper

A closure which consists of a normally held open damper installed in an air distribution system or in a wall or floor assembly and designed to close automatically in the event of a fire in order to maintain the integrity of the fire separation.

30) Smoke damper

A smoke damper is similar to fire damper. However, it closes automatically on sensing presence of smoke in air distribution system or in conditioned space.

31) Fire separation wall

The wall provides complete separation of one building from another or part of a building from another part of the same building to prevent any communication of fire of any access or heat transmission to wall itself which may cause or assist in the combustion of materials of the side opposite to that portion which may be on fire.

32) Refrigerant

The fluid used for heat transfer in a refrigerating system, which absorbs heat at a low temperature and low pressure of the fluid and rejects heat at a higher temperature and higher pressure of the fluid, usually involving changes of state of the fluid.

33) Global Warming Potential (GWP)

Global Warming can make our planet and its climate less hospitable and more hostile to human life. It is, therefore, necessary to reduce emission of green house gases such as Co₂, Sox, Nox and refrigerants. The potential of a refrigerant to contribute to Global Warming is called its GWP. Long atmospheric life time of refrigerants results in Global Warming unless the emissions are controlled.

34) Ozone Depletion Potential (ODP)

The potential of refrigerant or gasses to deplete the Ozone in the atmosphere is called ODP. The ODP values for various refrigerants are as under:-

R-11	1.000
R-12	0.820
R-22	0.034
R-123	0.012
R-134a	Nil

Due to high ODP of R-11, R-12, R-22 & R-123 their use in the air conditioning and refrigeration is being phased-out.

APPENDIX –B

LIST OF RELEVANT INDIAN STANDARDS

I.S. 3615	Glossary of Terms Used in Refrigeration & Air Conditioning.
I.S. 325	Three phase Induction Motors
I.S. 1822	Motor Starters of voltage Not Exceeding 1000 volts
I.S. 3624	Bourden Tube Pressure and Vacuum Gauges
I.S. 2372	Timber for cooling towers
I.S. 7403	Code of practice for selection of standard worm and helical gear boxes
I.S. 1620	Horizontal centrifugal pumps for clear, cold, fresh water
I.S. 996	Single phase small A.C. and Universal motors
I.S. 1239	Mild steel tubes, tubulars and other wrought steel fittings
I.S. 3589	Electrically welded steel pipes for water, gas and sewage,
I.S. 6392	Steel pipe flanges
I.S. 778	Gun metal gate, globe and check valves for general purpose
I.S. 2592	Recommendation for methods of measurement of fluid flow by mean plates and nozzles
I.S. 277	Galvanised steel sheets
I.S. 737	Wrought aluminium and aluminium alloy sheet and strip for general engineering purposes.
I.S. 655	Metal air ducts
I.S. 732	Code of practice for electrical wiring and fittings for buildings
I.S. 2516	A.C.circuit breakers
I.S. 900	Code of practice for installation and maintenance of induction motors
I.S. 1248	Direct acting electrical indicating instruments
I.S. 2516	A.C. circuit breakers for voltages not exceeding 1000 volts
I.S. 4047	Heavy duty air break switches and composite units of air break switches and fuses for voltage not exceeding 1000 volts.
I.S. 2208	HRC cartridge fuse links upto 650 volts
I.S. 1554 (PART I)	PVC insulated (heavy duty) electric cables for working voltage including 1100 volts
I.S. 8183	Specification for bonded glass wool/ mineral wool
I.S. 4671	Specification for expanded polystyrene for thermal insulation purposes.
I.S. 11561	Code of practice for testing of cooling towers.
I.S. 7896	Data for outside design conditions for air conditioning for summer months
I.S. 8148	Package air conditioners
I.S. 2370	Sectional cold rooms (walk-in type)
I.S. 5111	Testing of refrigerant compressors
I.S. 10594	Thermostatic Expansion Valve
IS 12615	Energy efficient induction motors

Energy Conservation Building Code 2007

National Building Code of India 2005

APPENDIX – C

I.S. SAFETY CODES

- I.S. 660 Safety Code for Mechanical Refrigeration
- I.S. 659 Safety Code for air conditioning
- I.S. 3016 Code of Practice for Fire precautions in welding and cutting operations
- I.S. 818 Code of practice for safety and health requirements in electrical and ga and cutting operations.
- I.S. 5216 Code for safety procedure and practice in electrical works
- I.S. 3696 Safety code for scaffolds and ladders

**APPENDIX -D
HEAT LOAD CALCULATION PROFORMA**

Name Of Job				Location				ESTIMATE FOR				LOCAL TIME				PEAK LOAD				LOCAL TIME																																																																											
Space used for				SIZES				sq.ft X				Cu Ft				LOCAL TIME				SUN TIME																																																																											
SIZES				X =				sq.ft X =				Cu Ft				LOCAL TIME				SUN TIME																																																																											
ITEM				ARE OR QUANTITY				SUN GAIN OR TEMP. DIF.				FACTOR				BTU / HOUR				HOURS OF OPERATION				CONDITIONS																																																																							
																DB				WB				%RH				DP				GR/ LB																																																															
SOLAR GAIN - GLASS																OUTDOOR (OA)																																																																															
GLASS																ROOM (RM)																																																																															
GLASS																DIFFERENCE																																																																															
GLASS																VENTI- LATION																																																																															
GLASS																PEOPLE X																CFM/ PERSON =																																																															
SKYLIGHT																DOORS X																CFM/ DOORS =																																																															
																CFM VENTILATION																																																																															
SOLAR & TRANS. GAIN - WALLS & ROOF																SWINGING REVOLVING																																																																															
WALL																DOORS																PEOPLE X																CFM/ PERSON =																																															
WALL																OPEN DOORS																DOORS X																CFM/ DOORS =																																															
WALL																EXHAUST FAN																																																																															
WALL																CRACK																FEET X																CFM/ FT =																																															
ROOF-SUN																																																CFM INFILTRATION																																															
ROOF-SHADED																																																CFM OUTDOOR AIR THRU APPARATUS																CFM																															
																																																																CFM																															
TRANS. GAIN - EXCEPT WALLS & ROOF																APPARATUS DEWPOINT																																																																															
ALL GLASS																ESHF																EFFECTIVE ROOM SENS. HEAT																EFFECTIVE ROOM SENS. HEAT																=																															
PARTITION																																SENS HEAT =																EFFECTIVE ROOM TOTAL HEAT =																FACTOR																															
CEILING																																																																																															
FLOOR																ADP																INDICATED ADP=																F																SELECTED ADP=																F															
INFILTRATION																																																																																															
INTERNAL HEAT																DEHUMIDIFIED AIR QUANTITY																																																																															
PEOPLE																TEMP. RISE																(1 - BF) X (Trm F - Tadb F) =																F																																															
POWER																DEHUM CFM																EFFECTIVE ROOM SENS. HEAT =																CFMda																																															
LIGHTS																																1.08 X F temp rise																																																															
APPLIANCES ETC																																ROOM SENS. HEAT =																F (rm outlet air)																																															
ADDITIONAL HEAT GAINS																																1.08 X CFMda																																																															
SUB TOTAL																SUPPLY AIR QUANTITY																																																																															
STORAGE																SUPPLY CFM																ROOM SENS. HEAT =																CFMsa																																															
																																1.08 x Fdesired diff																																																															
SUB TOTAL																BYPASS CFM																CFMsa - CFMda =																CFMba																																															
SAFETY																																																																																															
ROOM SENSIBLE HEAT																RESULTING ENT & LVG CONDITIONS AT APPARATUS																																																																															
SUPPLY																EDB																Trm F + CFMda X (Toa F - Trm F) =																Tedb F																																															
DUCT																																																																																															
HEAT GAIN																LDB																Tadb F + BF X (Tedb F - Tadb F) =																Tldb F																																															
OUTDOOR AIR																																FROM PSYCH. CHART: Tawb F, Tlwb F																																																															
EFFECTIVE ROOM SENSIBLE HEAT																NOTES																																																																															
LATENT HEAT																																																																																															
INFILTRATION																																																																																															
PEOPLE																																																																																															
STEAM																																																																																															
APPLIANCES ETC																																																																																															
ADDITIONAL HEAT GAINS																																																																																															
VAPOR TRANS																																																																																															
SUB TOTAL																																																																																															
SAFETY FACTOR																																																																																															
ROOM LATENT HEAT																																																																																															
SUPPLY DUCT LEAKAGE LOSS																																																																																															
OUTDOOR AIR																																																																																															
EFFECTIVE ROOM LATENT HEAT																																																																																															
EFFECTIVE ROOM TOTAL HEAT																																																																																															
OUTDOOR AIR HEAT																																																																																															
SENSIBLE																																																																																															
LATENT																																																																																															
SUB TOTAL																																																																																															
RETURN																																																																																															
DUCT																																																																																															
HEAT GAIN																																																																																															
%+LEAK GAIN																																																																																															
%+PUMP																																																																																															
%+PIPE LOSS																																																																																															
GRAND TOTAL HEAT																																																																																															

**APPENDIX – E
HEAT LOAD CALCULATION PERFORMA FOR COLD STORAGE**

Estimate for :		Estimate for :	
Address		Date	
DESIGN INFORMATION			
Application		Room Dimensions	
		Outside	
Outside Ambient Temperature	Length (L)	ft.	Type
Room Temperature	Width (W)	ft.	Thickness
Temperature Difference (TD)	Height (H)	ft.	
Overall Wall Thickness in (If not known, use insulation thickness plus 2 inches)			
Product Load		Miscellaneous Loads	
		Number of people	
		Electrical watts	
		Other	
SOLUTION			
Outside Room, Surface Area (A)		Inside Room Volume (V)	
(L) x (W) =		Volume (V) = (L) x (W) x (H)	
(L) x (H) =		(V) = cu.ft	
(W) x (H) =			
Area (A) =	sq.ft.		
I) WALL LOAD			
(a) Area `A`		Sq.ft.	
(b) Wall Heat Gain Factor		BTU sq.ft. 24 hrs.	
(c) Load = (a) x (b)			
BTU 24 hrs.			
II) AIR CHANGE LOAD FRESH AIR			
(a) Volume `V`		CFF	
(b) Air changes		cu.ft.	
(c) Heat Removal		per 24 hrs.	
(d) Load = (a) x(b) x(c)		BTU cu.ft.	
BTU 24 hrs			
III) PRODUCT LOAD			
1. Temperature Reduction Load			
(a) Weight of product		lbs	
(b) Temperature reduction		`F	
(c) Specific heat			
(d) Load = (a) x(b) x (c)		=	
BTU 24 hrs			
2. Heat or Respiration Load			
(a) Weight of product		lbs	
(b) Heat of respiration		BTU lb.	
(c) Load = (a) x (b)		=	
BTU 24 hrs			
Note: Above steps must be repeated for each type product in room			
IV) MISCELLANEOUS LOADS			
(a) Heat equivalent per person		BTU hr.	
(b) Number of people x (a) x 24			
BTU 24 hrs			
(c) Electrical watts			
BTU 24 hrs			
(d) Other			
BTU 24 hrs			

V) TOTAL REFRIGERATION LOAD (I +II + III + IV)	
BTU 24 hrs	
VI) SAFETY FACTOR (10% OF TOTAL REFRIGERATOIN LOAD)	
BTU 24hrs	
VII) TOTAL REFRIGERATOIN LOAD WITH SAFETY FACTOR (V + VI)	
BTU 24 hrs	
VIII) REQUIRED HOURLY CAPACITY = VII	1/16 hrs.
BTU 24 hrs	

APPENDIX – F

PROFORMA FOR SCHEDULE OF TECHNICAL PARTICULARS

(A) COMPRESSOR :

For Reciprocating units

1. Manufacturer
2. Model
3. Overall dimensions (mm)
4. Weight (kg)
5. Size of foundation
6. Refrigerant
7. Test pressure (max.) (kg./sq.cm)
8. Maximum revaluations per minute
9. Minimum revolutions per minute for proper lubrication
10. Type of capacity control
11. No. of steps of capacity control
12. Capacity of the m/c at suction & condensing temperatures specified in Tender specification.
13. B.H.P. consumption

At conditions	As per tender Specification	As per system offered
at 100% load		
Part load step I		
Part load step II		
Part load Step III		
14. Crank case heaters
 - (i) Whether provided
 - (ii) Power rating (w)
15. Type of drive arrangement
16. No.of belts in case of V-belt drive
17. Whether oil pump is provided
18. Type of oil pump

For Centrifugal units

1. Manufacturer
2. Model
3. Type
4. (a) Refrigerant
(b) Weight of refrigerant per unit
5. Operating speed (RPM)
6. Type of drive and speed ratio
7. No. of impellers/ No. of stages
8. Out put in TR and input power consumption in KW, at the selected operating conditions

- | % of Load TR
condenser | Input KW at 0.0002 (metric)
fouling factor for condenser | Input KW at ARI fouling
factors for
& 0.0001 (metric) fouling
factor for chiller | and chiller |
|---------------------------|---|---|-------------|
| 100% load | | | |
| 75 % load | | | |
| 60% load | | | |
| 50% load | | | |
| 40% load | | | |
| 25% load | | | |
9. Type of capacity control
 10. Capacity control range
 11. Type of lubrication
 12. Material of bearing
 13. Operating weight (Kg.)
 14. Overall dimensions of the machine
 15. Compressor motor
 - i) Make
 - ii) Rated output
 - iii) Working voltage range
 - iv) Type of enclosure
 - v) Class of insulation
 - vi) Speed
 - vii) Full load current
 - viii) Starting current
 - ix) Efficiency
 - x) Power factor
 - xi) Temperature rise over ambient of 45 deg C.
 16. List of Safeties/protection provided in the chiller unit (Whether provided)
 - i) Motor over current
 - ii) Over voltage
 - iii) Under voltage
 - iv) Single cycle dropout/ intermittent power loss
 - v) Baring oil high temperature
 - vi) Low evaporator refrigerant temperature
 - vii) High condenser refrigerant pressure
 - viii) High motor temperature (For sealed/ semi hermetic chiller units only)
 - ix) Prolonged surge in compressor
 - x) Compressor starter faults
 - xi) Star-to-start and stop-to-stop timers for motor protection against rapid recycling
 - xii) Low lubricating oil pressure
 17. Details of all the functions of Microprocessor control system are to be enclosed.
Whether enclosed- Yes/ No.

(B) CONDENSER

1. Manufacturer

2. Shell dia (mm)
3. Type of fins, if any, in tubes
4. No. of passes
5. Water flow (L.P.M.)
6. Water velocity (M.P.S.)
7. Pressure drop at above velocity (M. of water)
8. Condensing Temp (deg C)
9. Tube material
10. Tube outside diameter (mm)
11. Tube thickness (mm)
12. Tube length (mm)
13. No. of tubes
14. Tube surface, inside (sq.m.)
15. Tube surface, outside (sq.m.)
16. Water temperature :
 - i) entering –deg C
 - ii) leaving – deg C

(C) CHILLER

1. Manufacturer
2. Type
3. Shell dia (mm)
4. Tube length (mm)
5. No. of tubes
6. tube material
7. Tube diameter (mm)
8. Tube surface inside (sq.m.)
9. Tube surface outside (sq.m.)
10. Type of fin
11. Refrigerant temp. (deg C)
12. No. of passes
13. Water flow (LPM)
14. Water velocity (MPS)
15. Pressure drop (M. of water)
16. Temperature of water :
 - (i) entering –deg C
 - (ii) leaving – deg C

(D) REFRIGERANT PIPING

1. Material for pipes
2. Pipe wall thickness (mm)
3. Material of fittings
4. Material of valves
5. Make of TX valve if provided
6. Make of refrigerant float if provided

(E) AIR HANDLING UNIT

1. General
 - (i) Manufacturer
 - (ii) Type of unit
 - (iii) Overall dimensions (mm)

- (iv) Operating weight (including wt. Of water/ refrigerant in circulation (kg)
- (v) Noise level
- 2. Material and thickness of drain pan
- 3. Fan Section :
 - (i) Manufacturer
 - (ii) Type of fan
 - (iii) Fan speed (RPM)
 - (iv) No.of fans
 - (v) Fan wheel diameter (mm)
- 4. Drive arrangement
- 5. No.of belts in case of belt drive
- 6. Material and thickness of fan wheel and blades
- 7. Material and thickness of housing
- 8. Fan outlet area (sq.m.)
- 9. Outlet velocity (MPM)
- 10. Total air quantity (CuM./ Min.)
- 11. Static pressure at outlet (mm of water)
- 12. Whether statically and dynamically balanced
- 13. Type of bearings.
- 14. Cooling Coil :
 - (i) Manufacturer
 - (ii) Type
 - (iii) Material of tubes
 - (iv) Material of fins
 - (v) Tube diameter
 - (vi) Tube thickness
 - (vii) Fin thickness
 - (viii) Method of bonding of tube and fins
 - (ix) No. of fins/ cm.
 - (x) No. of row deep
 - (xi) Total tube surface, outside (sq.m.)
 - (xii) Test pressure
 - (xiii) Coil face area
 - (xiv) Flow rate of water/ refrigerant (kg./Min. or L.P.M.)
 - (xv) Vol. Of water/ refrigerant through tube (MPS)
 - (xvi) No.of circuits
 - (xvii) Pressure drop in coil (Kg/ Sq/ cm. Of M. of water)
- 15. Air filters :
 - (i) Manufacturer
 - (ii) Type of medium
 - (iii) Filter medium
 - (iv) Material of frame work and its thickness (mm)
 - (v) Face area (Sq.m)
 - (vi) Face velocity across filters (MPS)
 - (vii) Pressure drop across filters (mm. of water)
- 16. Humidification arrangement :
 - (i) Type
 - (ii) Spray water rate (LPM)
 - (iii) Rating of spray pump, if provided (FHP)
 - (iv) Make and size of solenoid valve where provided
 - (v) Material of nozzles
 - (vi) No. of nozzles
- 17. Spray arrangement : (For sprayed coils only)

- (i) Pump casing
 - (ii) Rating of spray pump
 - (iii) Rate of spray (LPM/ SQ.M. of coil face area)
 - (iv) Spray density
 - (v) Material of nozzles
 - (vi) No. of nozzles
18. Electric strip heaters
- (i) Manufacturer
 - (ii) Type
 - (iii) Material of sheath
 - (iv) Material of fins
 - (v) Power rating (KW)

(F) COOLING TOWER :

1. Manufacturer
2. Type
3. Model
4. Overall dimensions (mm)
5. Weight with water (kg.)
6. No. of fans
7. CMH per fan
8. Outlet velocity (Mts. Per min)
9. Tip speed (Mts per min)
10. Drift loss (LPH)
11. Total water loss (LPH)
12. Approach to the design wet bulb (deg C)

(G) CENTRIFUGAL PUMPS :

(Give separate particulars for each application)

1. Manufacturer
2. Type
3. Model
4. Overall dimensions
5. Weight (Kg)
6. Size of foundations (mm)
7. Material :
 - (i) Pump casing
 - (ii) Impeller
 - (iii) Shaft
 - (iv) Shaft sleeve
 - (v) Base plate
8. Type of bearings
9. Type & material of seal
10. Speed (rpm)
11. Discharge (LPM)
12. Head (Mtr.)
13. Efficiency
14. Performance curves (whether enclosed with the tender)

(H) WATER PIPING :

1. Material for pipes
2. Material for fittings

3. Pipe wall thickness
4. Material for valves
5. Pressure gauges:
 - (i) Make
 - (ii) Range
 - (iii) Dial size
6. Flow meter type and make
7. Size of flow meter

(I) ELECTRICAL

1. Motors (Give separate particulars for each application)
 - (i) Manufacturer
 - (ii) Type and frame reference
 - (iii) Rated output (KW)
 - (iv) Range of working voltage (V)
 - (v) No. of phases
 - (vi) Rated frequency
 - (vii) Rated speed (RPM)
 - (viii) Full load current (amps)
 - (ix) Class of insulation
 - (x) Efficiency and power factor at the following loadings 100%, 75%, 50% 25% of Rated full load.
 - (xi) Type of bearings
2. Motor starters (Give separate particulars for each application):
 - (i) Manufacturer
 - (ii) Type
 - (iii) Rating
 - (iv) Whether the following protections are provided –
 - (a) Over load
 - (b) Under voltage
 - (c) Single phase prevention (for 3 phase motor starters)
3. Switch board :
 - (i) Manufacturer
 - (ii) Type
4. Circuit Breaker
 - (i) Manufacturer
 - (ii) Type
 - (iii) Rated normal current (amps)
 - (iv) Short circuit rating (MVA)
 - (v) Whether following are provided –
 - (a) O/L trip
 - (b) E/F trip
 - (c) Under voltage trip
5. Measuring Instruments :
 - (i) Manufacturer
 - (ii) Range
 - (iii) Dial size
 - (iv) Glass Index
6. Iron clad switch gears :
 - (i) Manufacturer
 - (ii) Make of HRC fuse provided

(J) CONTROLS :

1. Make and type of thermostats
2. Make and type of humidistats
3. Make and type of damper motor
4. Make and type of other control components

(K) DUCTING

1. Material
2. Manufacturer
3. Whether ducting is as per IS: 655

(L) INSULATION (For each application)

1. Manufacturer
2. Material and density
3. 'K' value at 10 deg C mean temperature
4. Thickness.

APPENDIX – G
PROFORMA FOR TEST RESULTS &
NOTES ON TEST INSTRUMENTS AND CAPACITY COMPUTATIONS

Sl.No.	Item	Test Results	
1.	Ambient conditions	D.B. Temp W.B.Temp %RH	- deg C - deg C
2.	Compressors	R.P.M Suction pressure Discharge pressure Oil pressure	- Kg/sq.cm -Kg/sq.cm -Kg/sq.cm
3.	Compressor Motors	R.P.M. Voltage Current (i)at 100% load (ii) at partial load (a) (b) (c)	- Volts - amps - amps - amps
4.	Water Chillers	Water flow rate Water temperature Entering Leaving Water pressure Entering Leaving	- LPM - deg C - deg C -Kg/sq.cm -Kg/sq.cm
5.	Condensers	Water flow rate Water temperature Entering Leaving Water pressure Entering Leaving	- LPM - deg C - deg C -Kg/sq.cm -Kg/sq.cm
6.	Pumps	R.P.M. Motor current Discharge pressure Suction pressure	-amps -Kg/sq.cm -Kg/sq.cm
7.	Cooling Towers	Water temperature Entering Leaving Wet bulb approach Fan motor current Fan motor voltage Fan motor R.P.M	- deg C - deg C - deg C - amps - volts
8.	Air handling units	Total air quantity across coil Coil face area Air temperature Entering (D.B.) Entering (W.B.) Leaving (D.B.) Leaving (W.B.) Water pressure Entering	- cu.m / min - Sq.m. - deg C - deg C - deg C - deg C -Kg/sq.m

		Leaving Water temperature Entering Leaving Water flow rate	-Kg/Sq.m - deg C - deg C - LPM
9.	Fresh air intakes	Face area Air quantity	- Sq.m - Cu.m/ min
10.	Room conditions at the working plane (No. of readings shall be taken and averaged out)	Temperature D.B. W.B.	- deg C - deg C
11.	Controls	Function of each control shall be tested and report furnished	

NOTES

A. Test Instruments

1. All instruments for testing shall be provided by the air conditioning contractor.
2. Thermometers used for measurement of temperature of water/ refrigerant shall have graduation of 0.1 deg C and shall be got calibrated from N.P.L. or any recognised test house before hand.
3. Thermometers used in the psychrometers shall have graduations of 0.2 deg C and shall be calibrated as at (2) above.
4. Pressure gauges shall also be got calibrated before hand from a recognised test house.
5. Orifice type of flow meters shall be used for measuring flow rate through the condensers and chillers.

B. CAPACITY COMPUTATIONS

1. Condensing unit :
The capacity shall be computed from the water temperatures and water flow rate measurements of the condenser water and the compressor motor current readings. A reference may be made, if necessary to the manufacturer's motor performance characteristics for arriving at the B.H.P. consumption.
2. Water chilling unit :
The capacity shall be computed from the water temperature and water flow rate measurements of the chiller. Heat rejection from the condenser shall be computed from the water temperature and water flow rate measurements at the condenser.
3. Cooling Tower :
Water quantity measured at the condenser and the temperature of water at the cooling tower shall be recorded. Wet bulb approach shall be checked against design data recorded in the tender documents.
4. Air handling unit (chilled water type) :
The capacity shall be computed from the water temperature and water flow rate measurement. A tolerance of $\pm 5\%$ from the tender documents value shall be acceptable in the capacity so computed. Air quantity shall be measured in the supply duct and checked with the quantity specified in the tender documents. a tolerance of $\pm 10\%$ in the air quantity shall be

acceptable. The enthalpy difference of air entering and leaving the coil shall be computed from air temperature and recorded.

5. Air handling unit (Dx type) ;
the capacity shall be computed from the air quantity measured in the supply air duct and the enthalpy difference between the air entering and leaving coil. Air quantity measured shall be checked with that recorded in the tender documents . A tolerance of $\pm 10\%$ from the tender documents value shall be acceptable.
6. For the purpose of system capacity, the refrigeration tonnage obtained from the main refrigeration plant will be accepted.
7. If due to any reason, internal load mentioned in the tender specifications is not available psychrometric computations for actual load conditions will be done and the plant, if found satisfactory will be accepted.

APPENDIX – H

MAINTENANCE

The section covers the maintenance schedule during warranty period and 5 yrs subsequent to the warranty period.

The maintenance provided during the warranty period shall be fully comprehensive and shall include but not limited to all equipments, labour part and emergency calls providing and site response within 24 hours. However during the maintenance period after the warranty is over, the materials shall be arranged by the department if any replacement is warranted. However consumable materials shall be arranged by the department during 6 yrs period including that of warranty period.

The maintenance shall also include a minimum of 12 monthly preventive maintenance visits by qualified personnel who are thoroughly familiar with the type of equipment and system provided for this project.

Chiller	Monthly Inspection and Service	<ol style="list-style-type: none"> 1. Check refrigerant level, leak test with electronic Leak detector. If abnormal, trace and rectify as necessary, Inform department in writing rectification. 2. Inspect level and condition of oil. If abnormal, trace fault and rectify as necessary. Inform department in writing on the rectification. 3. Check the liquid line sight glasses for proper flow. 4. Check all operating pressure and temperature. 5. Inspect and adjust, if required, all operating safety controls. 6. Check capacity control, adjust if necessary. 7. Lubricate vane/ linkage/ bearings. 8. Visually inspect machine and associated components, and listen for unusual sound or noise for evidence of unusual conditions. 9. Check lock bolts and chiller spring mount. 10. Review daily operating log maintained by department's operating personnel. 11. Providing written report to Department, outlining services carried out, adjustment made, rectification carried out and if the deficiency is of a major nature, arrange with department for shut- down to rectify equipment.
Chiller	Annual Inspection Prior to expiry of warranty period	<ol style="list-style-type: none"> 1. Perform all functions for monthly check 2. Check all flanges for tightness 3. Change oil in oil sump 4. Replace filter 5. Check oil temperature control 6. Check motor terminals 7. Check connections in starter

		<p>Please note that oil filter gasket replacement shall deem to be included in the contract.</p> <ol style="list-style-type: none"> 1. Check motor earthing, meggar motor and connection wiring on each leg 2. Check motor temperature cut-out, tighten motor terminals. 3. Check starter contacts, arc shield, transformer. 4. Check dashpot oil, clean dashpot and replace oil when necessary 5. Test and calibrate overload setting. 6. Inspect, calibrate and adjust to original specifications all gauges, safety and operating controls including low temperature and high pressure cutout, oil pressure switch, load limit relay and electrical interlocks. 7. For water cooled condenser systems, inspect condenser tubes for fouling. If fouling exceeds original specifications, the contractor shall carry out cleaning of the tubes at his own expense. 8. For air-cooled condenser coils, dust should not be allowed to accommodate on the condenser coil surfaces. Cleaning should be as often as necessary (approximately every three months) to keep coil clean. Exercise care when cleaning the coil, so that the coil fins are not damaged. Under no circumstances this unit be cleaned with acid based cleaner.
Water pumps	Monthly Inspection	<ol style="list-style-type: none"> 1. Inspect all water pumps 2. Check all seals, glands and pipelines for leaks and rectify as necessary. 3. Re-pack and adjust pump glands as Necessary. 4. Check all pump bearings and lubricate with oil or grease as necessary. 5. Check the alignment and condition of all rubber couplings between pumps and drive motors and rectify as necessary. 6. Check all bolts and nuts for tightness and tighten as necessary.
Water pumps	Annual Inspection prior to expiry of warranty period	<ol style="list-style-type: none"> 1. Perform all function for monthly checks 2. Check motor earthing, meggar Motor and connection wiring on each leg. 3. Tighten motor terminals 4. Check starter contacts 5. Test and calibrate overload setting.

Expansion tank	Annual inspection prior to expiry of warranty period	1. Inspect expansion tank, Drain, clean and flush out tanks as necessary
----------------	--	--

Air handling units and fancoil units	Monthly inspection	<ol style="list-style-type: none"> 1. Inspect all air handling and fan coil units. 2. Check all air filters and clean or change filters as necessary. 3. Check all water coils, seals and pipelines for leaks and rectify as necessary. 4. Check and re-calibrate modulating valves and controls. Adjust and rectify as necessary to ensure compliance to the original specifications. 5. Purge air from all water coils. 6. Check all fan bearings and lubricate with grease as necessary. 7. Check the tension of all belt drives and adjust as necessary. 8. Check and clean all the condensate pans, trays and drains. 9. Check measure and re-calibrate all sensors if necessary. 10. Check, clean and service smoke detectors. Carry out a system test to ensure that the smoke detector will trip the AHU's. 11. Check spring vibration isolators for vibration. Rectify if necessary. 12. Coil to be cleaned by (a) spray of high-pressure clean water (not exceeding 30 psi) (b) with chemical spray, if necessary.
Air handling units and fan coil units	Annual Inspection prior to expiry of warranty period	<ol style="list-style-type: none"> 1. Perform all functions for monthly checks. 2. Tighten motor terminals 3. Check starter contacts. 4. Test and calibrate overload settings.

Air cooled packaged units and precision-computer air-condition equipment	Monthly check	<ol style="list-style-type: none"> 1. Check condenser fan motor load ampere. 2. Check fan and motor mounting brackets. 3. Check shafts and bearings. Lubricate with grease as necessary. 4. Check the tension of all belt drives and adjust as necessary. 5. Check for refrigerant leaks with electronic leak detector. 6. Check electrical terminals and contactors operation and connection for tightness. 7. Check compressor motor current. 8. Check refrigerant line driers and moisture indicators.
Air cooled packaged units and precision-ac equipment	Annual inspection prior to expiry of period.	Perform all functions listed in the monthly checks.
Air distribution system	Monthly and annual inspection prior to expiry of warranty period	<ol style="list-style-type: none"> 1. Check operation of all modulating and fixed dampers controlling air flow through unit. Lubricate all damper bearings and linkages as necessary. 2. Carry out space temperature checks on air-conditioned areas with thermo hydrograph. Balance air flow as necessary to compliance with requirements of original specifications. These checks include the calibration of sensors, thermostat, etc. 3. Check noise level of discharged air from diffusers.
Ventilation	Monthly check and inspection prior to expiry of warranty period	<ol style="list-style-type: none"> 1. Check adjust as necessary the air flow of all fans are in compliance with the original specifications. 2. Check the tension of all belt drives and adjust as necessary. 3. Check and lubricate all fan bearings. 4. Tighten motor terminals. 5. Check starter contacts. 6. Test and calibrate overload settings. 7. A system check shall be carried out for all Mechanical ventilation (MV), Pressurisation and Exhaust system to verify the performance of the systems.

Switch board	Six-monthly and annual inspection prior to the expiry of the warranty period	<ol style="list-style-type: none"> 1. Clean and adjust all switch gear, contactors, relays and associated equipment at intervals not exceeding six months. 2. Check and prove operation of thermal over load and protection devices. 3. Check and ensure tightness of all equipment fastenings and cable terminations within switch boards. 4. Vacuum clean all switch board cubicles.
Piping system	Monthly and annual inspection prior to expiry of warranty period	<ol style="list-style-type: none"> 1. Check all piping system for leaks and repair these where they have occurred. 2. Check for damage & deterioration of insulation or sheathings. Rectify as necessary
	Consumable materials	<p>The department shall supply the following consumable materials as and when required :-</p> <ol style="list-style-type: none"> 1. All oils and greases required for lubrication of compressors, fan bearings, motors bearings, pivots and other moving parts. 2. All refrigerant required for topping up. Refrigerant loss if due to manufacturing defect or due to negligence shall be made good by the contractor. 3. All consumable filter elements/ rolls. 4. All chemicals for the correct chemical treatment of the cooling tower and chilled water system. 5. All carbon brushes required to replace worn brushes in electric motors. 6. All electric contact points required to replace worn electric contact points in switchgears, motor starter gears, electronic control gears and electric relays. 7. All electric fuses required to replace blown fuses. <p>Just before the expiry of the warranty of the contract, the contractor shall carry out a complete system operability test on all the systems or sub-systems as called for in the contract.</p> <p>The purpose of the test is to verify that the performance of all the systems or sub-systems in the contract is in accordance to the specifications. All test shall be carried out in the presence of the Engineer-in-Charge or his representative.</p> <p>The warranty period is deemed to be over if the department or his</p>

		representative is completely satisfied with the system performance during the test.
--	--	---

APPENDIX - I

Typical A.C. PLANT LAYOUT FOR 3 NOS. 550 TR CENTRIFUGAL CHILLING UNITS (ONE STAND BY)

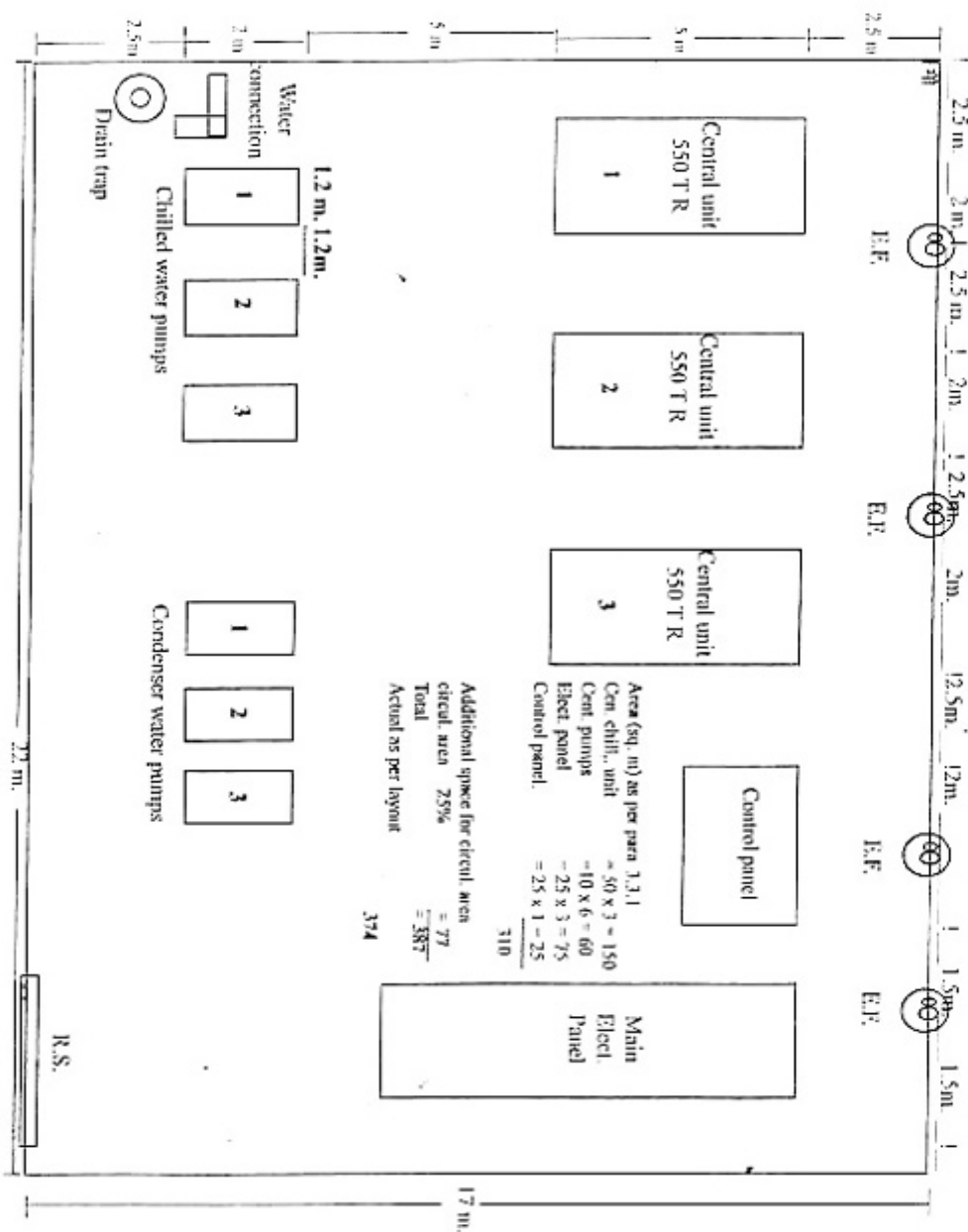

APPENDIX -J

TYPICAL AHU ROOM LAYOUT FORM 680 CMM (24000 CFM) AHU

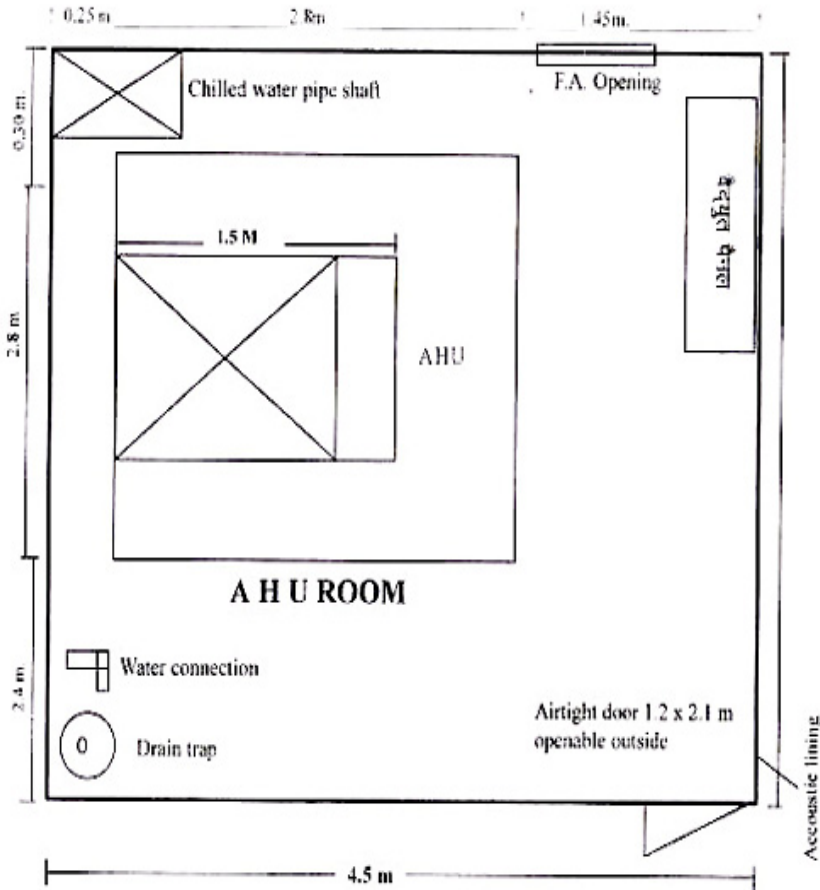





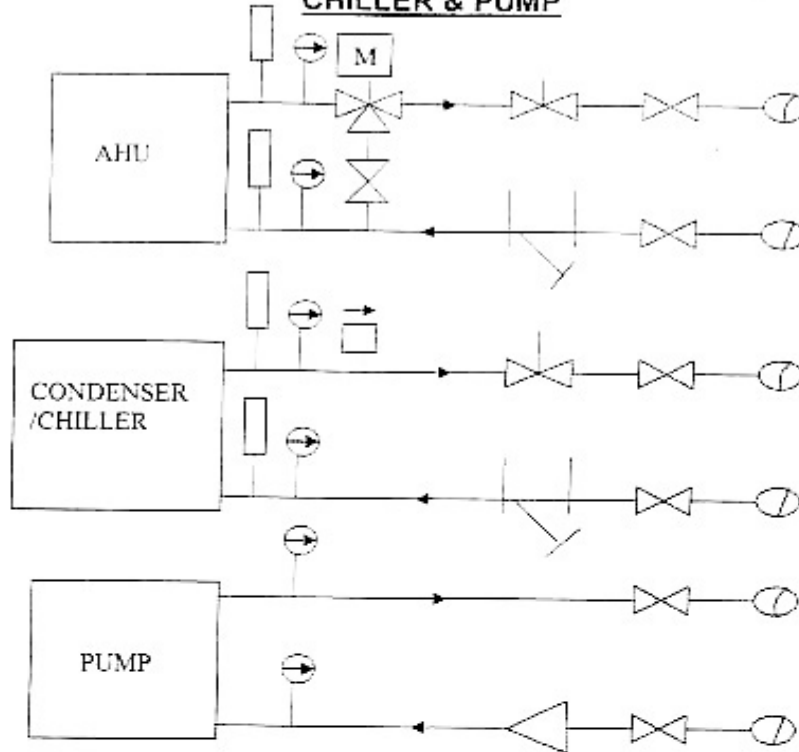



APPENDIX -K

TYPICAL PIPING CONNECTION FOR AHU, CONDENSOR/ CHILLER & PUMP

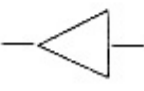

LEGENDS:

	Thermometer		Balancing valve
	Pressure Gauge		Butterfly valve
			Y-strainer
	3way modulating valve*		Non return valve
			Flow switch

Note: *2 way modulating valve to be used wherever VFD/VSD is being used.

APPENDIX – L

AIR-SIDE ECONOMIZER ACCEPTANCE PROCEDURES

1.1 Construction Inspection

Prior to Performance Testing, verify and document the following:

- i) System controls are wired correctly to ensure economizer is fully integrated (i.e. economizer will operate when mechanical cooling is enabled)
- ii) Economizer lockout control sensor location is adequate (open to air but not exposed to direct sunlight nor in an enclosure; away from sources of building exhaust; at least 8 m [25 ft] away from cooling towers)
- iii) System is provided with barometric relief, relief fan or return fan to control building pressure

1.2 Equipment Testing

Step 7: Simulate a cooling load and enable the economizer by adjusting the lockout control set-point. Verify and document the following:

- i) Economizer damper modulates opens to 100% outside air
- ii) Return air damper modulates closed and is completely closed when economizer damper is 100% open
- iii) Economizer damper is 100% open before mechanical cooling is enabled
- iv) Relief fan or return fan (if applicable) is operating or barometric relief dampers freely swing open

Step 8: Continue from Step 1 and disable the economizer by adjusting the lockout control set-point. Verify and document the following:

- i) Economizer damper closes to minimum ventilation position
- ii) Return air damper opens to at or near 100%
- iii) Relief fan (if applicable) shuts off or barometric relief dampers close. Return fan (if applicable) may still operate even when economizer is disabled

APPENDIX – M

VALUES OF PERFORMANCE CHARACTERISTICS OF ENERGY EFFICIENT INDUCTION MOTORS

Table I Values of Performance Characteristic of 2 Pole Energy Efficient Induction Motors
(Clauses 1.2, 1.3, 4.1.1, 4.1.2, 14.1, 17.1, 17.1.1 and 17.1.2)

Rated Output	Frame Designation	Full Load Speed	Full Load Current	Breakaway Torque in Terms of Full Load Torque	Breakaway Current in Terms of full Current, Equal or Below		Nominal Efficiency	
		Min	Max	Min	For eff 2	For eff 1	For eff 2	For eff 1
kW		Rev/min	Amp	Percent	Percent	Percent	Percent	Percent
(1)	(2)	(3)	(4)	(5)	(6)	(7)	(8)	(9)
0.37	71	2 790	1.2	170.0	600	650	66.0	70.2
0.55	71	2 760	1.6	170.0	600	650	70.0	74.0
0.75	80	2 780	2.0	170.0	600	650	73.0	77.0
1.1	80	2 790	2.8	170.0	600	650	76.2	82.8
1.5	90S	2 800	3.7	170.0	600	650	78.5	84.1
2.2	90L	2 810	5.0	170.0	650	700	81.0	85.6
3.7	100L	2 820	8.0	160.0	650	700	84.0	87.5
5.5	132S	2 830	11.0	160.0	650	700	85.7	88.6
7.5	132S	2 840	15.0	160.0	650	700	87.0	89.5
9.3	160M	2 840	18.5	160.0	650	700	87.7	90.0
11.0	160M	2 860	21.5	160.0	650	700	88.4	90.5
15.0	160M	2 870	29.0	160.0	650	700	89.4	91.3
18.5	160L	2 880	35.0	160.0	650	700	90.0	91.8
22.0	180M	2 890	41.5	160.0	650	700	90.5	92.2
30.0	200L	2 900	54.0	160.0	650	700	91.4	92.9
37.0	200L	2 900	67.0	160.0	650	700	92.0	93.3
45.0	225M	2 955	80.0	160.0	650	700	92.5	93.7
55.0	250M	2 960	95.0	160.0	650	700	93.0	94.0
75.0	280S	2 970	130.0	160.0	650	700	93.6	94.6
90.0	280M	2 970	150.0	160.0	650	700	93.9	95.0
110.0	315S	2 980	185.0	160.0	650	700	94.0	95.0
125.0	315M	2 980	209.0	160.0	650	700	94.5	95.3
132.0 ¹⁾	315M	2 980	220.0	160.0	650	700	94.5	95.3
160.0 ¹⁾	315L	2 980	265.0	160.0	650	700	94.8	95.5

NOTE — Output to frame size relation is maintained in accordance with IS 1231 for all motors, except those marked as ¹⁾, wherein the frame size indicated is 'preferred frame size'.

Table 2 Values of Performance Characteristic of 4 Pole Energy Efficient Induction Motors
(Clauses 1.2, 1.3, 4.1.1, 4.1.2, 14.1, 17.1, 17.1.1 and 17.1.2)

Rated Output	Frame Designation	Full Load Speed	Full Load Current	Breakaway Torque in Terms of Full Load Torque	Breakaway Current in Terms of Full Current, Equal or Below		Nominal Efficiency	
		Min	Max	Min	For eff 2	For eff 1	For eff 2	For eff 1
kW		Rev/min	Amp	Percent	Percent	Percent	Percent	Percent
(1)	(2)	(3)	(4)	(5)	(6)	(7)	(8)	(9)
0.37	71	1 330	1.4	170.0	550	600	66.0	73.0
0.55	80	1 340	1.7	170.0	550	600	70.0	78.0
0.75	80	1 360	2.2	170.0	550	600	73.0	82.5
1.1	90S	1 370	2.9	170.0	550	600	76.2	83.8
1.5	90L	1 380	3.8	170.0	550	600	78.5	85.0
2.2	100L	1 390	5.1	170.0	600	700	81.0	86.4
3.7	112M	1 410	8.1	160.0	600	700	84.0	88.3
5.5	132S	1 420	11.4	160.0	600	700	85.7	89.2
7.5	132M	1 430	15.4	160.0	600	700	87.0	90.1
9.3	160M	1 430	18.5	160.0	600	700	87.7	90.5
11.0	160M	1 440	22.0	160.0	600	700	88.4	91.0
15.0	160L	1 440	30.0	160.0	600	700	89.4	91.8
18.5	180M	1 440	36.0	160.0	600	700	90.0	92.2
22.0	180L	1 440	43.0	160.0	600	700	90.5	92.6
30.0	200L	1 450	56.0	160.0	600	700	91.4	93.2
37.0	225S	1 450	69.0	160.0	650	700	92.0	93.6
45.0	225M	1 460	84.0	160.0	600	700	92.5	93.9
55.0	250M	1 460	99.0	160.0	600	700	93.0	94.2
75.0	280S	1 470	134.0	160.0	600	700	93.6	94.7
90.0	280M	1 470	164.0	160.0	600	700	93.9	95.0
110.0	315S	1 480	204.0	160.0	600	700	94.4	95.2

Table 3 Values of Performance Characteristic of 6 Pole Energy Efficient Induction Motors
(Clauses 1.2, 1.3, 4.1.1, 4.1.2, 14.1, 17.1, 17.1.1 and 17.1.2)

Rated Output	Frame Designation	Full Load Speed	Full Load Current	Breakaway Torque in Terms of Full Load Torque	Breakaway Current in Terms of Full Current, Equal or Below		Nominal Efficiency	
		Min	Max	Min	For eff 2	For eff 1	For eff 2	For eff 1
kW		Rev/min	Amp	Percent	Percent	Percent	Percent	Percent
(1)	(2)	(3)	(4)	(5)	(6)	(7)	(8)	(9)
0.37	80	870	1.4	160.0	550	600	65.0	69.4
0.55	80	870	1.9	160.0	550	600	68.0	72.0
0.75	90S	890	2.3	160.0	550	600	71.0	74.6
1.1	90L	900	3.2	160.0	550	600	74.0	77.3
1.5	100L	900	4.0	160.0	550	600	76.0	79.6
2.2	112M	910	5.5	150.0	600	700	79.0	82.2
3.7	132S	920	8.8	150.0	600	700	82.5	85.1
5.5	132M	920	12.7	150.0	600	700	84.5	86.8
7.5	160M	930	16.7	150.0	600	700	86.0	88.1
9.3	160L	930	20.5	140.0	600	700	87.0	89.3
11.0	160L	935	23.0	140.0	600	700	87.5	89.7
15.0	180L	940	30.5	140.0	600	700	88.5	90.5
18.5	200L	940	37.5	140.0	600	700	89.5	91.3
22.0	200L	945	44.0	140.0	600	700	90.0	91.8
30.0	225M	945	59.0	140.0	600	700	91.0	92.6
37.0	250M	950	72.0	140.0	600	700	91.5	93.0
45.0	280S	960	87.0	140.0	600	700	92.0	93.4
55.0	280M	960	107.0	140.0	600	700	92.5	93.8
75.0	315S	970	145.0	140.0	600	700	93.0	94.2
90.0	315M	970	175.0	140.0	600	700	93.3	94.5
110.0 ¹⁾	315M	970	214.0	140.0	600	700	93.5	94.6
132.0 ¹⁾	315L	980	257.0	140.0	600	700	93.8	94.9

NOTE — Output to frame size relation is maintained in accordance with IS 1231 for all motors, except those marked as ¹⁾, wherein the frame size indicated is 'preferred frame size'.

Table 4 Values of Performance Characteristic of 8 Pole Energy Efficient Induction Motors
(Clauses 1.2, 1.3, 4.1.1, 4.1.2, 14.1, 17.1, 17.1.1 and 17.1.2)

Rated Output	Frame Designation	Full Load Speed	Full Load Current	Breakaway Torque in Terms of Full Load Torque	Breakaway Current in Terms of Full Current, Equal or Below		Nominal Efficiency	
		Min	Max	Min	For eff 2	For eff 1	For eff 2	For eff 1
kW		Rev/min	Amp	Percent	Percent	Percent	Percent	Percent
(1)	(2)	(3)	(4)	(5)	(6)	(7)	(8)	(9)
0.37	90S	640	1.5	150.0	550	600	62.0	66.8
0.55	90L	640	2.1	150.0	550	600	67.0	71.1
0.75	100L	650	2.7	150.0	550	600	70.0	73.8
1.1	100L	660	3.5	150.0	550	600	72.0	76.2
1.5	112M	670	4.5	150.0	550	600	74.0	77.9
2.2	132S	680	6.1	140.0	600	700	77.0	80.5
3.7	160M	690	9.8	140.0	600	700	80.0	83.0
5.5	160M	690	14.2	140.0	600	700	82.5	85.1
7.5	160L	695	19.0	140.0	600	700	84.0	86.4
9.3	180L	700	23.0	140.0	600	700	85.0	87.3
11.0	180L	700	26.0	140.0	600	700	86.0	88.1
15.0	200L	705	35.0	130.0	600	600	87.0	89.0
18.5	225S	705	45.0	130.0	600	700	88.0	89.8
22.0	225M	710	52.0	130.0	600	700	88.5	90.2
30.0	250M	710	70.0	130.0	600	700	90.0	91.5
37.0	280S	710	86.0	130.0	600	700	90.5	91.9
45.0	280M	720	99.0	130.0	600	700	91.0	92.4
55.0	315S	720	118.0	130.0	600	700	91.5	92.8
75.0	315M	730	153.0	130.0	600	700	92.3	93.5
90.0 ¹⁾	315L	730	182.0	130.0	600	700	92.8	93.9
110.0 ¹⁾	315L	730	218.0	130.0	600	700	93.3	94.3

NOTE — Output to frame size relation is maintained in accordance with IS 1231 for all motors, except those marked as ¹⁾, wherein the frame size indicated is 'preferred frame size'.

APPENDIX – N
LIST OF CFC AND HCFC FREE REFRIGERANT

Refrigerant	Ozone Depleting Potential	Global Warming Potential	Application
R-427 a	0	1830	Recommended retrofit for R-22 DX systems.Used in A/C, medium and low temperature systems.
R-410 A	0	1725	Replacement for R-22 in smaller size chillers,and residential and light commercial A/C systems. Never used as a retrofit for R-22.
R-407 C	0	1525	Replacement/retrofit for R-22 in DX systems. Used in A/C, medium and low temperature systems.
R-134 a	0	1300	Replacement/retrofit for R-12 and R-500 systems. Recommended retrofit for R-12 automotive A/C systems.
R-404 a	0	3260	Replacement/retrofit for R-502 and R-22. Used in medium and low temperature systems.
R-507 a	0	3300	Replacement/retrofit for R- and R-22. Used in medium and 502 low temperature refrigeration systems.

