



For Office Use Only

Government of India - Ministry of Railways

Booklet on

DRAFT

HT VACUUM CIRCUIT BREAKER PANELS



CAMTECH/E/2024-25/EP-05/HT VCB/1.0

END USER

GENERAL SERVICE MAINTENANCE
OFFICERS & STAFF



INDIAN RAILWAYS

CENTRE FOR ADVANCED MAINTENANCE TECHNOLOGY (CAMTECH)
MAHARAJPUR, GWALIOR-474005

BOOKLET ON

High Tension Vacuum Circuit Breaker



CONTENT

ABBREVIATIONS.....	1
CHAPTER 1	2
GENERAL DESCRIPTION.....	2
1.1 PROTECTIVE DEVICES FOR VARIOUS VOLTAGE LEVEL	2
1.2 HT VCB PANELS	3
1.3 CLASSIFICATION OF HT VCB PANEL.....	3
1.3.1 Based on Installation Location.....	3
1.3.2 Based on Operation Mechanism	3
1.3.3 Based on Voltage Rating	3
1.3.4 Based on Application	3
CHAPTER 2.....	4
CONSTRUCTIONAL FEATURES	4
2.1 GENERAL ARRANGEMENTS	4
2.1.1 Mechanical Interlocks.....	4
2.1.2 Safety Shutters.....	5
2.2 COMPONENT OF INDOOR VCB PANEL	5
2.2.1 Vacuum Circuit Breaker (VCB)	5
2.2.2 Current Transformer.....	6
2.2.3 Potential Transformers	6
2.2.4 Protective Relay	7
2.2.5 Measuring Instruments.....	8
2.2.6 Bus Bars and Connectors	8
2.2.7 Earthing of switchgear and controlgear	8
CHAPTER 3.....	9
WORKING PRINCIPLE AND SELECTION CRITERIA	9
3.1 WORKING PRINCIPLE	9
3.2 RATED OPERATING SEQUENCE.....	9
3.3 SELECTION CRITERIA.....	10
3.3.1 Selection of VCB.....	10
3.3.2 Selection of CT	10
3.3.3 Selection of PT	11

CHAPTER 4	12
PACKAGING, SHIPPING AND STORAGE.....	12
4.1 TRANSPORTATION	12
4.2 RECEIPT OF MATERIAL AT SITE / STORE.....	12
4.3 UNLOADING	13
4.4 HANDLING.....	13
4.5 STORAGE.....	14
4.5.1 Storage Procedure	14
4.5.2 Indoor Storage	14
4.5.3 Outdoor Storage	15
CHAPTER 5	16
INSTALLATION & COMMISIONING	16
5.1 COMMISSIONING AS PER M/S ABB	16
5.1.1 For VCB Panels	16
5.1.2 For VCB Unit.....	17
5.2 COMMISSIONING AS PER M/S CG POWER AND INDUSTRIAL SOLUTION LTD:.....	19
5.2.1 Commissioning check on VCB without enclosure.....	19
5.2.2 Commissioning check on enclosure without VCB.....	19
5.2.3 Final Inspection on enclosure with VCB is in Test/ Service.....	20
CHAPTER 6	22
OPERATION & PREVENTIVE MAINTENANCE	22
6.1 DO'S AND DON'TS FOR OPERATION	22
6.1.1 DO'S	22
6.1.2 DON'T'S.....	22
6.2 FLOW CHART FOR OPERATION OF VCB.....	23
6.3 PREVENTIVE MAINTENANCE.....	23
6.3.1 For M/s Lauritz & Knudsen (Formerly L&T)	24
6.3.2 For M/s ABB (Model No. UniGear ZS1).....	26
6.3.3 For M/s Schneider Electric.....	27
CHAPTER 7	28
TROUBLESHOOTING AND SOLUTIONS	28
7.1 FOR M/S LAURITZ KNUDSEN (FORMERLY L&T).....	28
7.2 FOR M/S SCHNEIDER ELECTRIC	29

7.2.1	Circuit Breaker Installed as Fixed or Withdrawable.....	29
7.2.2	Complement Only for Withdrawable Circuit Breaker.....	31
REFERENCE		33
NOTES		34
CONTACT US.....		35

LIST OF TABLES

Table 1: Supply Voltage and protective device used.....	2
Table 2: Various Ratings of Indoor type VCB	10
Table 3: Check Points for Commissioning of VCB Unit.....	17
Table 4: Commissioning check on VCB without enclosure.....	19
Table 5: Commissioning check on enclosure without VCB.....	19
Table 6: Final Commissioning Checks & Inspection.....	21
Table 7: Maintenance of VCB Panel Make: Lauritz Knudsen	24
Table 8: Maintenance of VCB Panel Make: Schneider Electric	27
Table 9: Troubleshooting for VCB Panel Make: Lauritz Knudsen.....	28
Table 10: Troubleshooting for both Fixed or Withdrawable Circuit Breaker Make Schneider Electric	29
Table 11: Additional Troubleshooting only for Withdrawable Circuit Breaker Make: Schneider Electric.....	31

LIST OF FIGURES

Figure 1: VCB and their components	5
Figure 2: Vacuum Interrupter Unit.....	6
Figure 3: Cast Resin Type Current Transformer (CTs).....	6
Figure 4: Protection System Scheme	9
Figure 5: Packed Panel with Plastic Wrap and Cardboard Cover at the bottom and location of Nuts and Bolts.....	12
Figure 6: VCB Panel along with VCB unit	13
Figure 7: VCB Panel with or without VCB unit	13
Figure 8: Crane Rope and Lifting Hook Arrangement.....	14
Figure 9: Flow chart of erection process.....	16
Figure 10: Flow diagram of Operation of a Circuit Breaker	23

ABBREVIATIONS

ABBREVIATION	FULL FORM
AC	Alternating Current
AH	Ampere Hours
CAT	Category
CB	Circuit Breaker
CPWD	Central Public Works Department
CT	Current Transformer
DB	Distribution Board
DC	Direct Current
E/F	Earth Fault
FDB	Final Distribution Board
HRC	High Rupturing Capacity
HT	High Tension
IEC	International Electro-Technical Commission
IR	Insulation Resistance
IS	Indian Standards
kV	Kilo Volt
LED	Light Emitting Diode
LT	Low Tension
MCB	Miniature Circuit Breaker
MDB	Main Distribution Board
MRI	Meter Reading Interface
MVA	Mega Volt Ampere
NC	Normally closed
NO	Normally Opened
O&M	Operation and Maintenance
O/L	Overload
OEM	Original Equipment Manufacturer
PT	Potential Transformer
RMU	Ring Main Unit
S/C	Short Circuit
SCADA	Supervisory Control and Data Acquisition
SMF	Sealed Maintenance Batteries
TC	Trip Coil
TOD	Time of Day
VCB	Vacuum Circuit Breaker
VT	Voltage Transformer



CHAPTER 1

GENERAL DESCRIPTION

Protective devices in a substation are essential for ensuring the safety, reliability, and efficiency of the power system. Their primary function is to detect faults and isolate the affected section to prevent damage to equipment and ensure uninterrupted power supply. The key reasons for installing protective devices in a substation include:

- Fault Detection and Isolation – Quickly identifies short circuits, overloads, and other faults, preventing them from spreading.
- Equipment Protection – Safeguards transformers, circuit breakers, and other critical components from damage due to excessive current or voltage fluctuations.
- System Stability – Maintains the stability of the electrical network by minimizing disruptions caused by faults.
- Safety of Personnel – Reduces the risk of electrical hazards, ensuring the safety of workers and the public.
- Minimizing Downtime – Rapid fault clearance ensures continuous power supply and reduces system downtime.
- Preventing Fires and Explosions – Limits excessive current flow, reducing the risk of electrical fires and equipment failure.

Common protective devices used in substations include circuit breakers, relays, fuses, lightning arresters, isolators, and surge protectors. Each of these devices plays a crucial role in maintaining the integrity of the power system.

1.1 PROTECTIVE DEVICES FOR VARIOUS VOLTAGE LEVEL

The necessary protective devices, capable of carrying and breaking the current, must be installed as close as possible to the supply entry point. They should be easily accessible and able to fully isolate the power supply.

Table 1: Supply Voltage and protective device used

SN	Supply Voltage	Protective Device
1	Below 11 kV	Switch fuse unit or a circuit breaker by consumers
2	11 kV and above	A circuit breaker by consumers

In case of every transformer the following shall be provided, namely:

On primary side of transformer, a linked switch with fuse or gang operated air brake switch with fuse or circuit breaker of adequate capacity:

Provided that the linked switch with fuse on the primary side of the transformer may be of such capacity as to carry the full load current and to break only the magnetizing current of the transformer:

Provided further that for transformer having capacity of 1000 kVA and above, a circuit breaker shall be provided.



1.2 HT VCB PANELS

VCB panels are essential components in electrical power distribution systems, providing safe and efficient protection against faults in high-voltage circuits. These panels use vacuum circuit breakers (VCBs) to interrupt current flow and protect electrical equipment from damage.

HT (High Tension) VCB (Vacuum Circuit Breaker) panels are used in medium-voltage power distribution (typically from 3.3kV to 36kV) for switching and protection.

As per RB's Letter, CPWD General specifications for Electrical Works Part-IV Substation-2013" are comprehensive may be adopted over Indian Railways for sub-station items. In this specification section 2 is related to High Voltage Panel.

A railway 11kV substation generally uses two transformers of the same capacity-one in operation and the other on standby. The electricity supply from the board is received through an HT VCB panel, which also provides protection for the HT side of these transformers.

1.3 CLASSIFICATION OF HT VCB PANEL

The types of HT VCB panels are classified based on their application, design, and operational features. Here are the main types:

1.3.1 Based on Installation Location

- Indoor VCB Panel – Installed inside substations or switchgear rooms, protected from environmental factors.
- Outdoor VCB Panel – Designed for outdoor use with weatherproof enclosures.

1.3.2 Based on Operation Mechanism

- Fixed Type VCB Panel – The breaker is fixed inside the panel and cannot be removed for maintenance easily.
- Draw-out Type VCB Panel – The breaker can be removed from the panel, making maintenance easier.

1.3.3 Based on Voltage Rating

- 11kV VCB Panel – Common for industrial and commercial distribution systems.
- 22kV VCB Panel – Used for higher voltage distribution networks.
- 33kV VCB Panel – Typically found in transmission and large industrial plants.

1.3.4 Based on Application

- Single Busbar VCB Panel – Standard configuration for power distribution.
- Double Busbar VCB Panel – Provides redundancy and flexibility in switching.
- Feeder Protection/ Ring Main Unit (RMU) VCB Panel – Used in distribution networks for load switching or creating ring main system between multiple sub-station for incoming supply.



CHAPTER 2

CONSTRUCTIONAL FEATURES

VCB Panels shall be metal clad, indoor type, motor operated ON/OFF from front, Vertical/Horizontal isolation, horizontal draw out type truck of robust construction, fully Interlocked and extendable on both sides.

Separately earthed compartments shall be provided for circuit breakers, bus bars, relay & instruments, CT & PT and cable boxes, fully and effectively segregating these from one another so that fault in any one compartment do not cause damage to equipment in other compartment.

The housing shall be of bolted construction to ensure compact and rigid structure, presenting a neat and pleasing appearance. The sheet steel used should not be less than 2 mm thick.

2.1 GENERAL ARRANGEMENTS

The circuit breaker panels shall be complete with the following:

- (a) Racking in / Racking out mechanism.
- (b) Isolating plugs and sockets.
- (c) Mechanical inter-locks and safety shutters.
- (d) Mechanical ON/OFF indicator.
- (e) Minimum of 4 NO and 4 NC Auxiliary contacts directly operated by the circuit breaker. Additional NO & NC contacts can be provided with auxiliary contractors.
- (f) Anti-condensation space heaters suitable for operation on 240V, 50 Hz A.C. for each panel wherever specified.
- (g) Suitable tripping arrangement.
- (h) Mechanical counter to assess the total number of operations of the breaker (if asked for specifically).

2.1.1 Mechanical Interlocks

Mechanical interlocks are physical mechanisms designed to prevent unsafe operations by ensuring the correct sequence of actions in HT VCB (High Tension Vacuum Circuit Breaker) panels. These interlocks help avoid dangerous conditions like simultaneous operation of breakers or access to live parts.

Common Types of Mechanical Interlocks:

- Breaker Interlock: Prevents the VCB from being closed when the panel door is open, ensuring operator safety.
- Truck Interlock (for Drawout Type VCBs): Prevents racking in/out of the breaker unless it is in the OFF position.
- Earthing Switch Interlock: Ensures the breaker is OFF before the earthing switch can be engaged.
- Busbar Interlock: Prevents two different power sources from being connected simultaneously, avoiding back-feeding and faults.



2.1.2 Safety Shutters

Safety shutters are movable barriers in VCB panels that automatically cover live busbar contacts when the breaker is withdrawn (in drawout-type panels).

Function of Safety Shutters:

- Prevents accidental contact with live busbars when the breaker is removed.
- Operates automatically (opens when the breaker is inserted, closes when it is removed).
- Enhances electrical safety during maintenance

2.2 COMPONENT OF INDOOR VCB PANEL

An Indoor VCB Panel consists of several key components that ensure safe and efficient operation in medium-voltage power distribution. Below are the main parts of an Indoor VCB panel:

2.2.1 Vacuum Circuit Breaker (VCB)

The **Vacuum Circuit Breaker (VCB)** is the core switching device responsible for making and breaking the circuit under normal and fault conditions. It operates within a **vacuum chamber**, where the absence of air and other gases ensures rapid arc extinction. The VCB consists of:

- 2.2.1.1 Fixed & Moving Contacts:** When separated, an arc forms, but it is quickly extinguished due to the vacuum environment.
- 2.2.1.2 Operating Mechanism:** Uses spring-charged manual or motorized systems to open and close the breaker.
- 2.2.1.3 Interrupter Chamber:** Encapsulates the vacuum where the contact separation occurs, ensuring safe operation.
- 2.2.1.4 Insulation Housing:** Prevents electrical leakage and protects internal components.

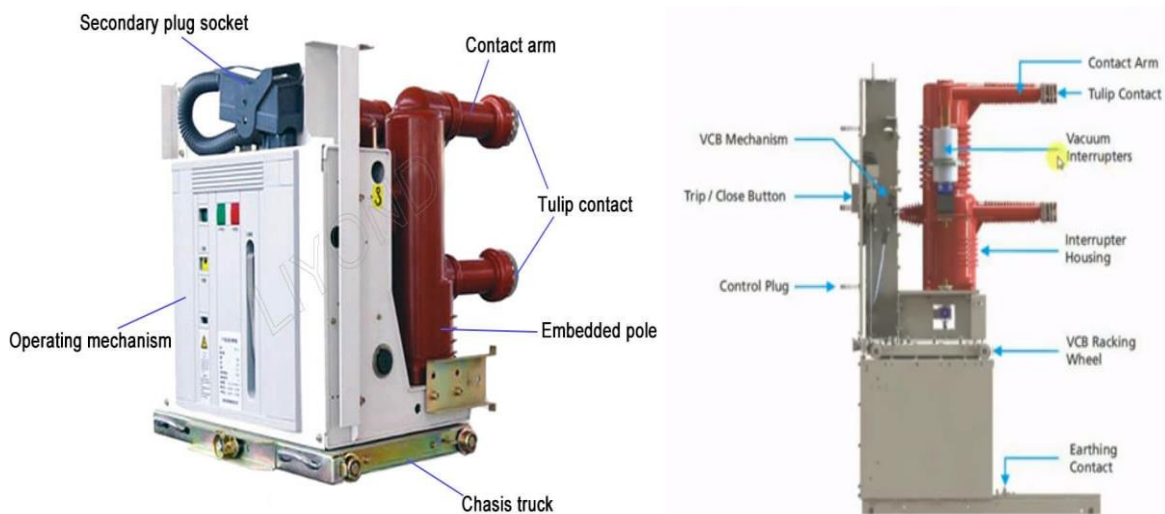

Figure 1: VCB and their components



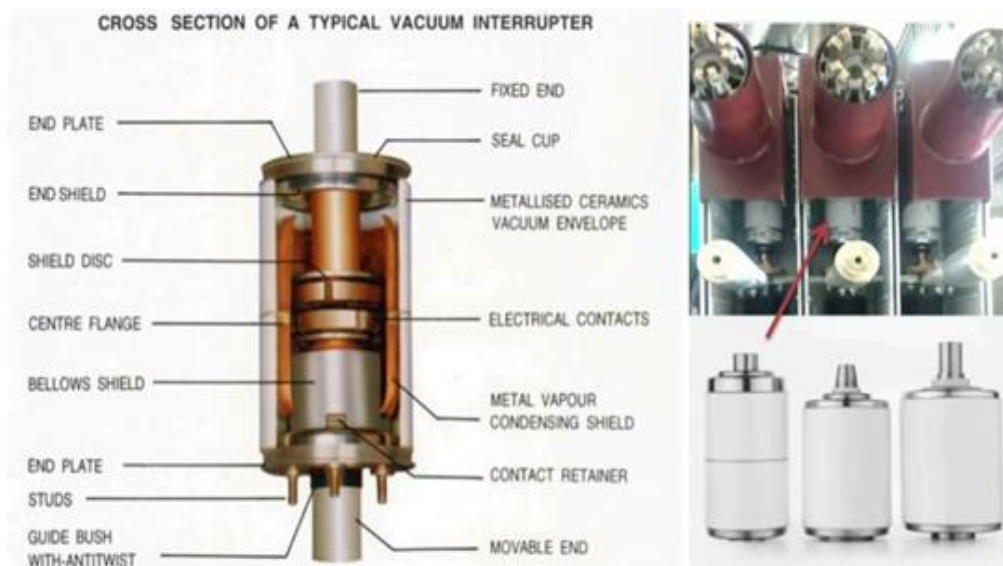

Figure 2: Vacuum Interrupter Unit

2.2.2 Current Transformer

Double wound resin cast current transformers of approved ratio burden 15 VA, accuracy class 10P-10 for protection and class 1.0 for metering, ON/OFF indications.



Figure 3: Cast Resin Type Current Transformer (CTs)

2.2.2.1 General Requirements

Accommodation shall be provided in the circuit breaker panel to mount one set of three numbers dual core dual ratio CTs for metering and protection purposes. Access to the CTs for cleaning, testing or changing shall be from the front, back or top of the panel.

2.2.2.2 Rating

Dual core & dual ratio CTs of suitable burden (but not less than 15 VA) shall be preferred with 5 Amps secondary. CT ratio shall be compatible with the loading pattern on HV side.

The CTs shall conform to relevant Indian Standards. The design and construction shall be robust to withstand thermal and dynamic stresses during short circuits. Secondary terminals of CTs shall be brought out suitably to a terminal block which will be easily accessible for testing and terminal connections. The protection CTs shall be of accuracy class 5P10.

The metering CTs shall conform to the metering ratio and accuracy class 0.5 for incomer and class 1 for outgoing panels.

2.2.3 Potential Transformers

A Potential Transformer (PT) (also called a Voltage Transformer, VT) is primarily used for voltage measurement, protection, and control in high-voltage systems. Its main applications include:

2.2.3.1 Metering & Measurement

PTs step down high voltage (e.g., 11kV, 33kV) to a safer, measurable level (e.g., 110V) for energy meters, voltmeters, and other measuring instruments. Ensures accurate voltage readings for system monitoring.

2.2.3.2 Protection System

Provides input signals to protective relays (e.g., overvoltage, undervoltage, and distance relays) for fault detection and tripping if voltage abnormalities occur.

It works with Relays like Numerical Relays, Distance Relays, and Voltage-Based Protection Relays.

2.2.3.3 SCADA & Remote Monitoring

PT output is used in SCADA (Supervisory Control and Data Acquisition) systems for real-time voltage monitoring and remote control.

A voltage transformer of 100 VA, 3x11000/110 volts, resin cast potential transformer of accuracy class 3 with protective fuses for protection.

A voltage transformer of burden not less than 100 VA. The accuracy class for the VT shall be class 0.5 for incomer and class 1 for outgoing panels. The transformer shall be of cast epoxy resin construction. It shall be fixed/withdrawable type. HRC fuses/ MCBs shall be provided on both HV and LV sides.

2.2.4 Protective Relay

The Relays shall be microprocessor based numerical relays with O/L, E/F and S/C protection. Tripping relay shall be used for tripping signal to the Shunt Trip Coil of Circuit Breaker operating on 24 V/ 30 V DC supply / Power pack / 110 V VT supply.

2.2.4.1 Relays setting

Over current Relays shall have adjustable setting for current from 50% to 200% and earth fault from 10% to 40% or 20% to 80%. These should be of manual reset type. All relays shall have a LED indicator which will indicate operation for each function. It shall be possible to reset it only by manual operation. The number and types of relays shall be as specified.

Note:

- ❖ 24V/ 30V DC shall be provided through 2 No. SMF batteries of 12/ 15 volts of minimum 26 AH capacity with a battery charger as per recommendation of the manufacturer both for protection as well as indications.
- ❖ Alternatively, Power Pack converters fed through PT/ 230V externally could be provided with 2 Nos., 12/ 15-volt, 7 AH SMF batteries (Power pack with condenser/ capacitor backup are also available which do not need batteries, these should not be used) for tripping.
- ❖ In cases where tripping is fed through PT, VA burden of PT shall be suitably increased (say 200 VA) as recommended by the manufacturer depending upon the number of panels and connected controls.
- ❖ In addition, external 24 volt / 30-volt DC supply shall be provided for indications etc. through 2 No. SMF batteries of 12/ 15 volts of minimum 26 AH capacity with a battery charger as per recommendation of the manufacturer.



2.2.5 Measuring Instruments

- (i) All instruments shall be switchboard type, back connected, suitable for flush mounting and shall comply with the requirements of latent issues of relevant Indian Standards. The instrument cases shall be dust proof, water tight, vermin proof and specially constructed to adequately protect the instruments against damage or deterioration due to high ambient temperature and humidity.
- (ii) All instruments shall be access adjustable and calibrated before dispatch and shall have means for calibration check and adjustment at site.
- (iii) All ammeters shall be digital type with direct reading scales. The scale value of ammeters shall be as per the primary current ratings of the associated current transformers. The rated current of ammeter elements shall be 5 Amperes and Accuracy class 1.0 as per IS: 1248.
- (iv) All voltmeters shall be of digital type with direct reading scales. The maximum scale value of voltmeters shall be 50% in excess of the primary voltage of associated PT. The rated voltage of the voltmeters shall be 110 volts A.C. and accuracy class shall be 1.0 as per IS: 1248.
- (v) Indicating watt meters shall be of digital type of accuracy class 1.
- (vi) Static digital tri-vector energy meter suitable for 3-phase 4-wire un-balanced load and CT, PT, ratio mentioned above, 0.5 accuracy class with load, survey and TOD/Tariff and MRI facility (with DLMS protocol compliant – CAT A)

2.2.6 Bus Bars and Connectors

2.2.6.1 General Requirement

The switch board shall be single bus bar pattern with air insulated encapsulated bus bars housed in a separate compartment, segregated from other compartments.

2.2.6.2 Material

The bus bars shall be of high conductivity electrolytic copper rated as specified with a minimum rated current of 630 Amps. The bus bars shall be sized for carrying the rated and short circuit current without over-heating. Maximum bus bar temperature shall not exceed 95 degree C.

2.2.7 Earthing of switchgear and controlgear

- Switchgear and controlgear shall be provided with a reliable earthing point for connection of an earthing conductor suitable for specified fault conditions. The connecting point shall be marked with the "protective earth" symbol, as indicated by symbol IEC 60417-5019:2006-08.
- Conductive parts of the switchgear and controlgear intended to be connected to the earthing system, may be designed to be part of the earthing circuit.
- All conductive components and enclosures that may be touched during normal operating conditions and are intended to be earthed shall be designed to carry 30 A (DC) with a voltage drop of maximum 3 V to the earthing point provided at the switchgear and controlgear.

NOTE:

For guidance on the connection of the earthing point of the switchgear and controlgear to the main station earth, Clause 10 of IEC 61936-1:2010 and IEC 61936-1:2010/AMD1:2014 [22] applies.



CHAPTER 3

WORKING PRINCIPLE AND SELECTION CRITERIA

3.1 WORKING PRINCIPLE

HT VCB panels operate by creating an arc inside a vacuum chamber when interrupting current. The vacuum effectively extinguishes the arc, allowing safe disconnection. The process follows these steps:

Fault Detection: Protection relays continuously monitor the electrical network.

Tripping: When an anomaly such as short circuit or overcurrent is detected, the relay sends a signal to the breaker.

Breaker Operation: The operating mechanism moves the breaker contacts apart, creating an arc.

Arc Extinction: The arc is extinguished in the vacuum chamber due to the absence of ionizable material.

Circuit Isolation: The circuit is safely isolated, preventing damage to equipment and ensuring operational safety.

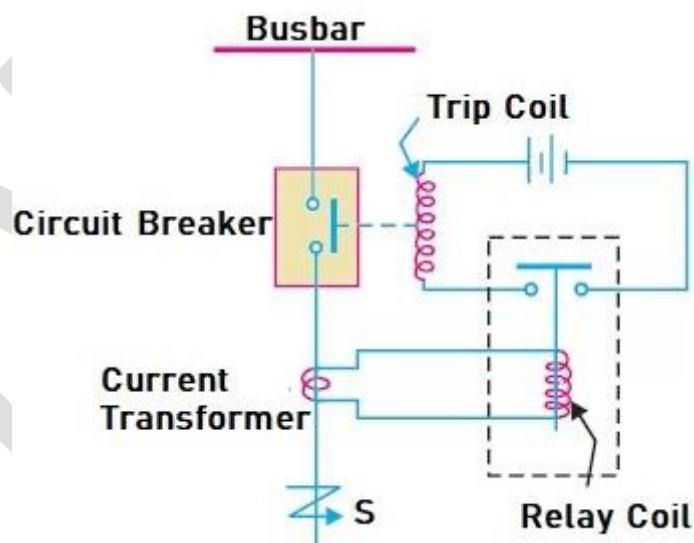

Figure 4: Protection System Scheme

3.2 RATED OPERATING SEQUENCE

The rated operating sequence is $O - t - CO - t' - CO$.

Where,

O: An opening operation,

CO: Close-open operating cycle with the shortest possible close-open time such that the circuit-breaker reaches the fully closed and latched position prior to opening,

t: 3 min for circuit-breakers for auto-reclosing.

Alternative values of 15 s and 1 min can be used; $t = 0.3$ s for circuit-breakers for rapid auto-reclosing; $t' = 3$ min. Alternative values of 15 s and 1 min can be used.

For some applications circuit-breakers can be used without auto-reclosing. For convenience of testing these types of circuit-breakers can be tested with the operating sequence specified for auto-reclosing.

3.3 SELECTION CRITERIA

3.3.1 Selection of VCB

Table 2: Various Ratings of Indoor type VCB

Rated Voltage	12KV
Rated Current	630A
Short Circuit MVA	350
Short Circuit Current	Upto 50 kA

3.3.2 Selection of CT

Selection of rating of Current transformer depends on the full load current of transformer

For Example:

Let Consider a setup where a 2×1000 kVA, 11/0.430 kV substation supplies power to a service building. This service building represents a typical installation and primarily consists of equipment such as Main Distribution Boards (MDB), Distribution Boards (DB), and Final Distribution Boards (FDB).

3.3.2.1 HT VCB Panel Configuration

For the protection of two transformers, a three-panel HT VCB setup is required. This consists of:

- One VCB panel for the incoming supply.
- Two VCB panels for outgoing connections to the transformers.

These three panels are interconnected using a busbar system for efficient power distribution.

3.3.2.2 CT Ratio for Outgoing VCB Panels

To determine the current transformer (CT) ratio, we first calculate the HT current for a 1000 kVA, 11/0.430 kV, 3-phase transformer:

$$\begin{aligned}
 I &= \frac{kVA}{\sqrt{3} \times kV} \\
 &= \frac{1000}{\sqrt{3} \times 11} = 52.49 \text{ Amp}
 \end{aligned}$$

Thus, the maximum current on the HT side of the transformer is approximately 53 A.



Accordingly, the standard CT rating for the outgoing transformer should be 60/5. However, in cases where the maximum load per transformer is below 30 A, the CT setting should be adjusted to 30 A. In such scenarios, the CT should be rated 60/30/5.

3.3.2.3 CT Ratio for Incoming VCB Panel

Since the CT ratio for each outgoing transformer is 60/30/5, the appropriate CT ratio for the incoming VCB panel should be 120/60/5 to ensure proper load balancing and protection.

3.3.3 Selection of PT

Selection of rating of Potential transformer depends on the voltage rating of HT VCB panel or incoming voltage of transformer.

3.3.3.1 HT VCB Panel Configuration

PT shall be 11KV/110 V AC.

DRAFT



CHAPTER 4

PACKAGING, SHIPPING AND STORAGE

4.1 TRANSPORTATION

The switchgear panel is packed in shipping carton box case with the circuit breaker inside the panel as shown in figure below. Although the panel is wrapped in polyethylene bag it is advised to store the packed cases in shelter and in clean dry and well-ventilated place as the equipment is basically designed for the indoor use.

The panel base frame is bolted with bottom of the wooden packing palette as seen in fig. below. Other special tools, accessories, bus bars, etc are packed and supplied in a separate box.

The medium voltage circuit breakers are delivered firmly locked condition and must always be transported or stored in an upright position. The circuit breaker is shipped in packing in the open (OFF) position and with the closing spring discharged.



Figure 5: Packed Panel with Plastic Wrap and Cardboard Cover at the bottom and location of Nuts and Bolts

4.2 RECEIPT OF MATERIAL AT SITE / STORE

Check for any external transit damages on receiving the material. In case any such damage is found, do not further open the packing and intimate our works. If the packing cases are intact, open them and tally the quantity with the packing list. Accessories such as the manual charging handle, the rack-in/out handle.

- Each delivery is to be checked on receipt for:
- Completeness and correctness (Check against order and delivery documents).
- Any possible damage in transit and material losses.

Abnormality, if any, must be notified immediately to:

- The manufacturer
- The forwarding agent and the insurance company
- The responsible claims inspector according to the insurance certificate for the purpose of making out a damage or loss Certificate.

4.3 UNLOADING

Unloading of the package units must only be carried out with a crane, fork lift truck and / or transport trolley jack.

4.4 HANDLING

- Carefully remove the shipping carton from the panel.
- Unscrew the bolts used for fixing bottom wooden palette with the base frame (Use spanner of appropriate size), if panel is to be lifted by chain/crane, remove the bottom palette.
- Keep the panel on the finished flooring.
- Open the VCB chamber door and remove the transit locking brackets of the VCB/ withdrawable truck as shown below:

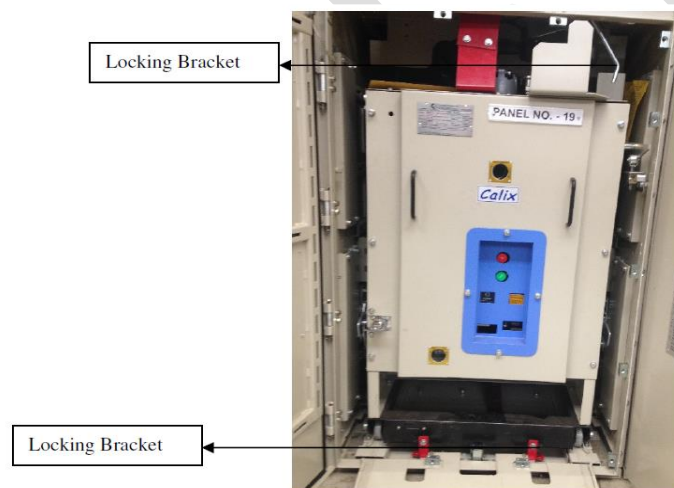

Figure 6: VCB Panel along with VCB unit

- Take out the VCB trolley out of the panel by unfolding the ramp as shown below:



Figure 7: VCB Panel with or without VCB unit



- Keep the shipping palette for use later in case the circuit breaker is to be store prior to its installation.
- Check for any damage.
- Put sling in the four lifting eye bolts on the top of the panel and lift it. The inclined angle of the slings should not be more than 60 degrees.
- Move the panel to the place of installation and lower it slowly aligning the foundation bolts with the holes on the base frame.
- Do not, in any case, push the panel on ground or use pipe roller or tommy bar as this may damage the base frame.
- The circuit breaker truck can also be moved using a properly rated fork-lift vehicle. The wooden pallets are designed for movement by a standard fork-lift vehicle.
- The base where panel is to be installed should be well leveled concrete floor.
- The variation in floor leveling shall not be more than 1.25mm over the span 1.4 meter.
- In case of any special foundation requirement refer the foundation drawings from as built drawings supplied with panel.

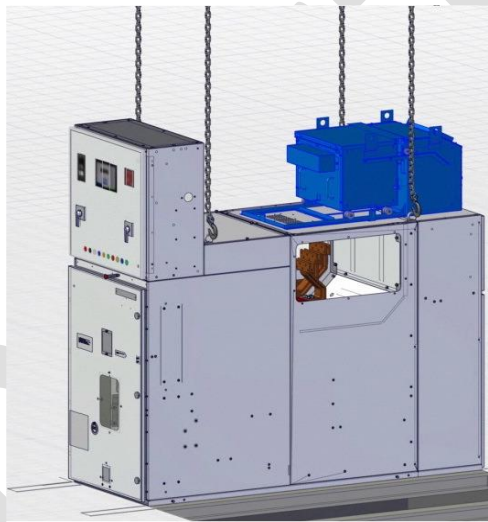

Figure 8: Crane Rope and Lifting Hook Arrangement

4.5 STORAGE

The material shall be stored in a well-ventilated storage room and to be protected against dirt, damage and water ingress. The original packing can be used for storage.

4.5.1 Storage Procedure

Whenever possible, install circuit breaker in their assigned switchgear enclosures for storage.

When the circuit breaker will be placed on its pallet for storage, be sure the unit is securely bolted to the pallet and covered with polyethylene film at least 0.254 mm (10 mils) thick.

4.5.2 Indoor Storage

Whenever possible, store the circuit breaker indoors. The storage environment must be clean, dry and free of such items as construction dust, corrosive atmosphere, mechanical abuse, and rapid temperature variations.



4.5.3 Outdoor Storage

Outdoor storage is not recommended. When no other option is available, the circuit breaker must be completely covered and protected from rain, snow, dirt and all other contaminants.

Space Heating: Proper storage space heating measures shall be adapted for both indoor and outdoor storage to prevent condensation and corrosion.

DRAFT



CHAPTER 5

INSTALLATION & COMMISSIONING

The installation and commissioning of vacuum circuit breaker mentioned here for indoor type in air insulated switchboards/ Panel. Before panel board is commissioned, provision of the safety namely fire extinguishers, rubber mats and danger board shall be also ensured.

The flow chart of complete process of unpacking, installation are given as under:

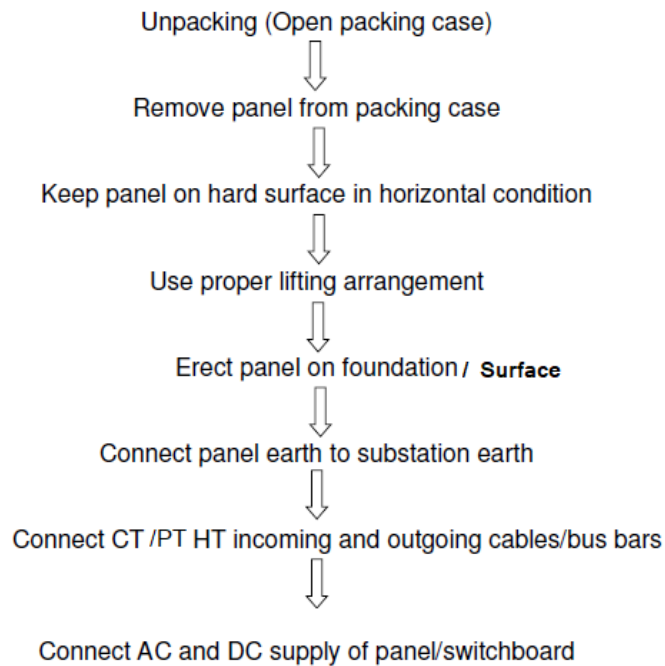

Figure 9: Flow chart of erection process

5.1 COMMISSIONING AS PER M/S ABB

5.1.1 For VCB Panels

In preparation for commissioning, the following work must be carried out prior to connection with the high voltage power supply:

- ↻ Check the general condition of the switchgear for any damage or defects.
- ↻ Visually inspect the switching devices, withdrawable parts, isolating contacts, insulating parts, etc.
- ↻ Check connection of the main earthing bar to the installation earthing conductor (following the appropriate safety regulations).
- ↻ Check the paintwork for damage and, where necessary, touch up.
- ↻ Remove all residues of materials, foreign bodies and tools from the switchgear.
- ↻ Clean the switchgear, rubbing down insulating parts with a soft, dry, clean, non-fraying cloth. Remove any greasy or sticky dirt.
- ↻ Correctly remount all covers etc. removed during assembly and testing procedures.
- ↻ Transport caps on heavy duty vacuum circuit - breakers if applicable - must be removed.
- ↻ Lifting eyebolts on high current vacuum circuit - breakers must be removed if still fitted.

- ↻ In switchgear panels with an additional ventilation system – flap hanging in partition must rest loosely against leaf spring (with the centrifugal fan at a standstill, if fitted).

5.1.2 For VCB Unit

The following instructions must also be followed, together with the instructions mentioned above.

Before putting the VCB circuit-breaker into service, carry out the following operations:

- ↻ Check tightness of the power connections to the circuit-breaker terminals;
- ↻ Establish the setting of the primary electronic overcurrent release (if provided);
- ↻ Check that the value of the power supply voltage of the auxiliary circuits is between 85% and 110% of the rated voltage of the electrical accessories;
- ↻ Check that no foreign bodies, such as bits of packing, have got into the moving parts;
- ↻ Check that there is a sufficient exchange of air in the installation place to avoid overtemperatures;
- ↻ Also carry out the checks indicated in table below:

Table 3: Check Points for Commissioning of VCB Unit

SN	Item inspected	Procedure	Positive check
1	Insulation resistance (IR)	Medium voltage circuit (11 kV) With a 2500 V megger, measure the insulation resistance between the phases and the exposed conductive part of the circuit.	The insulation resistance should be at least 50 Mohm and in any case constant over time.
		Auxiliary circuits With a 500 V megger (if the apparatus installed allows this), measure the insulation resistance between the auxiliary circuits and the exposed conductive part.	The insulation resistance should be a few Mohm and in any case constant over time.
2	Auxiliary circuits.	Check that the connections to the control circuit are correct: proceed at the relative power supply.	Operations and signals normal.
3	Manual operating mechanism.	Carry out a few closing and opening operations. N.B. Supply the undervoltage release and the locking magnet on the operating mechanism at the relative rated voltage (if provided).	The operations and relative signals take place normally
4	Motor operator (if provided).	Carry out a few closing and opening operations. N.B. Supply the undervoltage release and the locking magnet on the operating mechanism at the relative rated voltage (if provided).	The spring is charged normally. The signals are normal. With the spring charged, the geared motor stops.
		Supply the spring charging geared motor at the relative rated voltage.	The geared motor recharges the spring after each closing operation.
5	Undervoltage release	Supply the undervoltage release at the relative rated voltage and carry out the	The circuit-breaker closes normally.

SN	Item inspected	Procedure	Positive check
	(if provided)	circuit-breaker closing operation	The signals are normal.
		Cut off power to the release.	The circuit-breaker opens. The signalling changes over.
6	Shunt opening release and additional shunt opening release (if provided).	Close the circuit-breaker and supply the shunt opening release at the relative rated voltage.	The circuit-breaker opens normally. The signals are normal.
7	Shunt closing release (if provided)	Open the circuit-breaker and supply the shunt closing release at the relative rated voltage.	The circuit-breaker opens normally. The signals are normal.
8	Key lock (if provided)	Open the circuit-breaker, keep the opening pushbutton depressed, then turn the key and remove it from the housing. Attempt the circuit-breaker closing operation	Neither manual nor electrical closing takes place.
		Put the key back in and turn it 90°. Carry out the closing operation.	Both electrical and manual closing take place normally; in this position the key cannot be removed.
9	Locking electromagnet (RL ₁) (if provided).	With the circuit-breaker open, spring charged and locking electromagnet not supplied, attempt circuit-breaker closing both manually and electrically.	Closing is not possible.
10	Auxiliary contacts in the operating mechanism.	Insert the auxiliary contacts in suitable signalling circuits. Carry out a few closing and opening operations	Signals take place normally.
11	Locking electromagnet on the truck circuit-breaker (RL ₂) (if provided).	With the circuit-breaker open, in the isolated for test position and the locking electromagnet not supplied, attempt racking-in of the circuit-breaker.	Racking-in is not possible
		Supply the locking electromagnet and carry out the racking-in operation.	
12	Auxiliary transmitted contacts for signalling circuit-breaker racked-in, isolated (UniGear switchgear or PowerCube modules).	Insert the auxiliary contacts in suitable signalling circuits. With the circuit-breaker racked into the enclosure, carry out a few traverse operations from the isolated for test position to the connected position. Take the circuit-breaker to the racked-out position.	The signals due to the relative operations take place normally



5.2 COMMISSIONING AS PER M/S CG POWER AND INDUSTRIAL SOLUTION LTD:

5.2.1 Commissioning check on VCB without enclosure

Table 4: Commissioning check on VCB without enclosure

SN	Subject of Inspection	Procedure	Positive Check
1	Service & Test position	Check Insert and engage the racking handle from the front side of the panel. Rotate the handle in clock wise direction till SERVICE flag indication comes on the breaker. The breaker unit is ready for operation now.	Clockwise rotation shows – service position, & anti-clock rotation shows-Test position.
2	Insulation resistance (Primary)	With 2500V Megger, measure insulation resistance between phases and phase to earth in ON condition.	The insulation resistance should be at least 100 Mega Ohm & if the value is less found out the cause.
3	High-Potential Test (Vacuum Integrity Check (using Dielectric Test))	<ul style="list-style-type: none"> • Short one end of the primary connectors of all three phases and connect to earth. • Ensure that CB is in open / close condition. • Short the other end of all three phases and connect to HV Test Trolley. • Apply voltage and slowly increase up to 28kV as specified in breaker rating plate and keep for 1 minute. • The result shall be considered satisfactory if it withstands the voltage successfully. • Ensure primary connection of Surge Suppressor is disconnected. 	One minute power frequency withstand test shall be conducted on the Vacuum Circuit Breaker in open and close condition to ensure that the Vacuum in the interrupter is intact and there is no transit damage.

5.2.2 Commissioning check on enclosure without VCB

Table 5: Commissioning check on enclosure without VCB

SN	Subject of Inspection	Procedure	Positive Check
1	Connection Tightness	Carry out visual inspection & tight all the wire connections are firmly tightened. Use suitable size of screw driver for connection tightness.	All the wires of LT compartment are connected. Check all the covers of terminal blocks are provided.
2	Fuses and MCBs	Carry out visual inspection, check fuse are available of suitable ratings. All MCBs are in ON	Fuses are of suitable rating as per drawings.

SN	Subject of Inspection	Procedure	Positive Check
		position	
3	Tightness of bus bars	Tighten all the bus bars properly. Inspect all the bus bar joints fishplates are available. Suitable size hardware is used for bus bar connection.	Proper size of hardware is used. Bus bars are tight properly. The shrouds on bus bar joints are provided. The inter panel bus bar barriers is placed properly.
4	Extra holes blocking	Block the extra holes on panel outer body with suitable size of hardware or suitable blanking arrangement like grummet	Unused holes on panel are blocked properly
5	Earthing	Visual inspection of earthing connection to panel cubicles & LT compartment.	The permanent earthing is provided by means of earthing bus bar in all switchgear cubicles and LT compartment.
6	Removal of Foreign Material	Check any foreign material which likely disturbs the operations is removed. Like Nuts, Bolts, spanner, metallic tools etc.	No metallic foreign material which disturbs the operation is to be removed.
7	Low Voltage Connection	The auxiliary circuit connection shall be checked as per the relevant schematic diagram for correctness	All wires are connected, bus wires are properly laid, top cover is placed
8	High Voltage Connection	The HT cables are connected properly; tighten as per guideline of termination kit.	HT cables, CBCT, Bus Duct are properly connected.
9	Protection & Metering	Check all the meters and protective relays functions with the help of primary or secondary current injection method	All meters are showing correct readings, protections are functioning.

5.2.3 Final Inspection on enclosure with VCB is in Test/ Service

5.2.3.1 General Inspection/ Checks

Before putting the circuit breaker into service carry out the following checks:

- Check the tightness of the power connections on the circuit breaker terminals.
- Check that no foreign material has got into the moving parts.
- Check that air circulation in the circuit breaker installation site is adequate so that there is no danger of overheating.
- Put the circuit breaker back into the panel and close the main front door.



- Check that there are no gaps or uncovered holes in the panel anywhere and the whole installation is completely vermin proof.

5.2.3.2 Final Commissioning checks

Table 6: Final Commissioning Checks & Inspection

SN	Subject of Inspection	Procedure	Positive Check
1	Manual operating mechanism	Carry out a few closing and opening operation.	The operating and the relevant indications occur correctly.
2	Motor operated mechanism	Connect the geared motor for spring charging with the relative auxiliary supply voltage. Carry out a few closing and opening operations.	The geared motor recharges the spring after each closing operation.
3	Shunt trip coil (opening operation)	Close the circuit breaker. Connect the shunt trip coil with the relative rated auxiliary supply voltage. (Working range 70% to 110%)	The circuit breaker opens and the relevant indication occur correctly. Check in Test & Service position.
4	Shunt Close Coil (Closing operation)	Open the circuit breaker. Connect the shunt release with the relative rated auxiliary supply voltage. (Working range 85% to 110%)	The circuit breaker closes correctly and the relevant indications occur correctly. Check in Test & Service position.
5	Auxiliary contacts in the operating mechanism	Insert the auxiliary contacts into suitable auxiliary circuits. Carry out a few closing and opening operations of the circuit breaker.	The auxiliary contacts change their position NO contact to NC and NC contact to NO.
6	Test service position limit switch operation	Move the breaker from test to service few times.	Test service position indications occur correctly.
7	Insulation resistance (Primary)	With 2500V Megger, measure insulation resistance between phases and phase to earth. Note – Breaker should be in OFF condition to isolate CT section)	The insulation resistance should be at least 100 Mega Ohm & if the value is less found out the cause.
8	Insulation resistance (Secondary)	With 500V Megger, measure insulation resistance between phases and phase to earth	The insulation resistance should be at least 2 Mega Ohm & if the value is less find out the cause.
9	Functions of various interlocks	Check interlock functions	Interlock should function correctly.



CHAPTER 6

OPERATION & PREVENTIVE MAINTENANCE

6.1 DO'S AND DON'TS FOR OPERATION

The following do's and don'ts to be followed in VCB and VCB panel (Close door Operation Panel):

6.1.1 DO'S

Perform all the operations in CLOSE door condition only (Rack in, Rack out, Open and Close).

- Ensure following before racking the VCB from TEST to SERVICE position.
 - VCB is in TEST position.
 - VCB is in OPEN condition.
 - Earth switch is in OFF condition if provided.
 - Control circuit plug is fully engaged. Red lever on control plug mechanism should come upward direction when CONTROL PLUG is fully engaged.
- Ensure VCB compartment door is fully closed and all the bolts on VCB compartment door are fully Tightened.
- Earth switch should be operated when VCB is in DISCONNECTED position.
- Always cross check rating of the VCB before insertion inside the panel.
- Ensure complete switchboard is free from dust and any other foreign particles.
- Ensure all openings including hole provided for earthing connection are properly closed with seal to avoid any vermin/ reptile entry.
- Ensure that the shutter assembly is unlatched before inserting the VCB into the panel.
- Please keep the heater "ON" in all Panels including Dummy panel.

6.1.2 DON'T'S

- Do not apply any flammable lubrication on the busbar joints or VCB finger contacts.
- Do not perform any operations in OPEN door condition (Rack in, Rack out, Open and Close).
- Do not operate the interlocking lever on VCB.
- Do not try to rack in VCB when control plug is not engaged. By operating the VCB forcefully it may damage the control plug mechanism.
- Do not try to rack in VCB when VCB is in CLOSED condition.



- Do not try to operate Earth switch when VCB is in CONNECTED position if provided.
- Do not operate the VCB when castle lock is in LOCKED condition.
- Do not operate the padlock handles if door bolts are not tightened fully by Allen key.
- Do not try to insert wrong rating VCB inside the panel.
- Do not insert VCB without unlatching the shutter assemblies.
- Do not try to bypass VCB compartment door interlock when the feeder is in Live condition.

6.2 FLOW CHART FOR OPERATION OF VCB

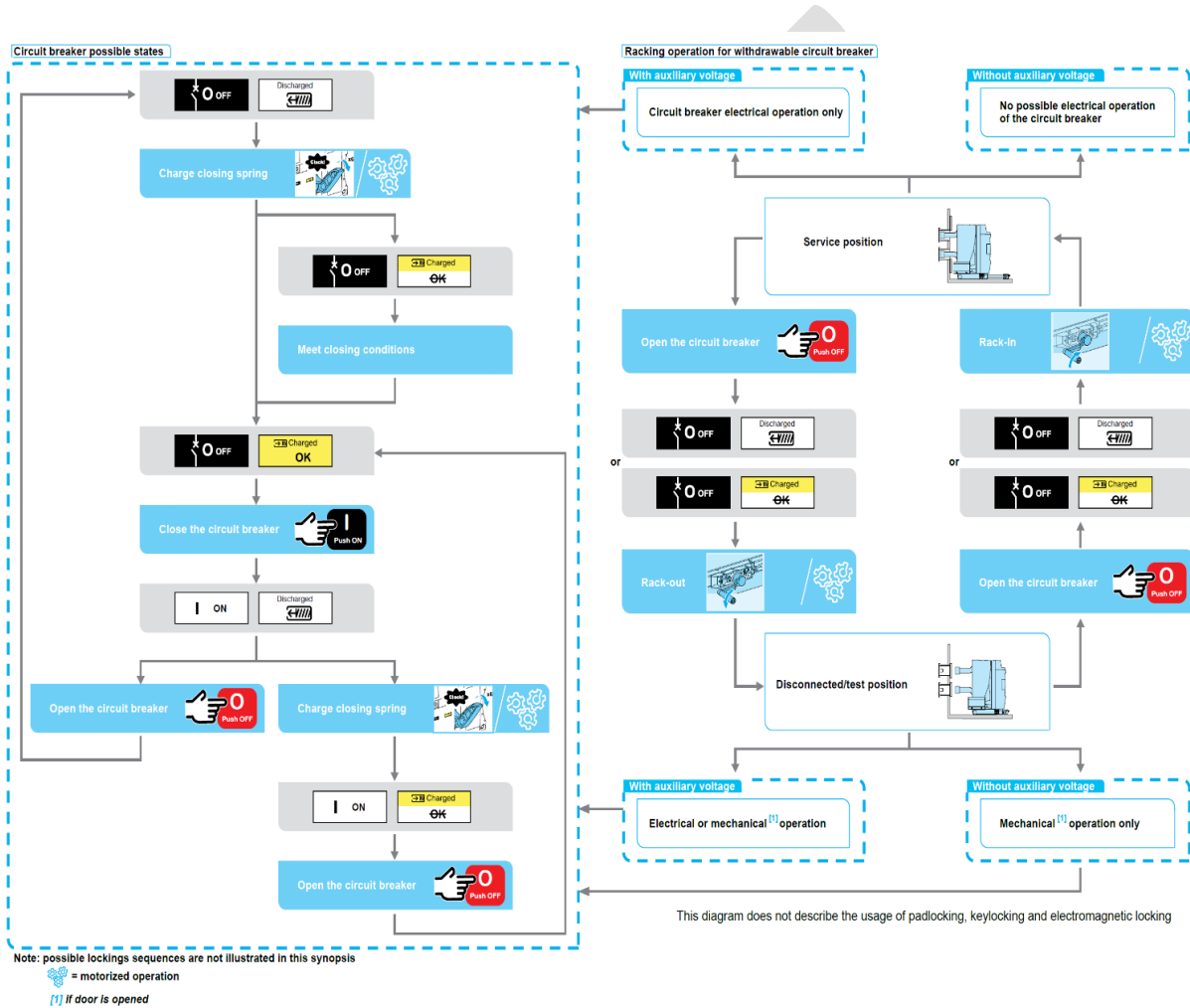

Figure 10: Flow diagram of Operation of a Circuit Breaker

6.3 PREVENTIVE MAINTENANCE

In order to assure a long lifetime and correct and reliable operation of equipment, it is of utmost importance to perform maintenance regularly this includes visual checks, apparatus cleaning, mechanical components lubrication, worn parts replacement and routine tests.

Permit to work should be taken from responsible authority before starting any maintenance work.

Every person involved in maintenance should follow the instruction of In-change at site during the work and take the necessary safety precautions of personal and equipment to avoid any accident or equipment damages during the maintenance & periodic inspection.

Maintenance activities and schedules recommended by OEMs may be differs from Manufacturer to Manufacturer and models for 11 kV indoor type VCB panels.

Some of the recommendation by Different OEMs are given under:

6.3.1 For M/s Lauritz & Knudsen (Formerly L&T)

Table 7: Maintenance of VCB Panel Make: Lauritz Knudsen

SN	CHECK POINT	CHECK ITEM	CHECK METHOD	CRITERIA	ACTION TO BE TAKEN
1	Entire Circuit Breaker	Tightness of bolts and nuts	By tightening them with screw driver and wrench with torque mark.	No loose connections	Re-tighten loose connections
		Dust and foreign matter	Visual check	The breaker should be clear of dust and stains.	Clean with a vacuum cleaner Wipe with a clean, dry cloth and recommended cleaning agent.
		Deformation, excessive wear and damage	Visual check	No deformation, excessive wear or damage.	Replace parts, if necessary.
		Lost or missing parts	Visual check	No missing parts	Replace missing parts.
2	Control circuit	Electrical closing and tripping	Check at the DISCONNECTED position	The closing and tripping operations can be done smoothly. Motor can spring charge automatically.	Check circuits and the closing and tripping devices. When the motor cannot spring charge, check the electric connection.
3	Auxiliary switch	Terminal	Tighten with screw driver	No loose screws	Re-tighten
		Moulding and Contacts	Visual check	No damage or deformation	Replace when damaged.
4	Operating mechanism	Dust and foreign matter	Visual check	There should be no dust and foreign matter.	Remove foreign matter with pressurized air.
		Smooth operation	Manual operation	Operation should be smooth	Clean off old lubricant and apply a small amount of fresh lubricant, if necessary.
		Lubricant of bearing pins	Check by sight and touch		
		Shaft of closing and	Visual check	Must rotate smoothly	

SN	CHECK POINT	CHECK ITEM	CHECK METHOD	CRITERIA	ACTION TO BE TAKEN
		tripping portion			
5	Vacuum interrupter	Contact wear	Visual check	Red wipe mark must be visible when breaker is in CLOSED position.	If red wipe mark cannot be seen, replace the vacuum interrupter.
		Vacuum pressure	The vacuum interrupter internal vacuum pressure can be checked by applying the voltage of 25 kV AC in this voltage withstand test.	When the internal vacuum pressure is not sufficiently high, breakdown will occur immediately. Hence 10 seconds of voltage application is sufficient.	Replace the vacuum interrupter when vacuum pressure is insufficient or Breaker is holding the supply for at least 10 Seconds.
		Number of OPEN - CLOSED operation	Counter reading	When the counter reading reaches 10,000 (for the rated current interruption), check the internal pressure. The next check shall be done at the reading of 15,000.	Replace the vacuum interrupter if the internal pressure is insufficient or when the counter reading reaches 20,000.
6	Main circuit disconnects/ Contact finger	Dis-coloration of contacts	Visual check	There should be a thin film of electrical grease on the contact surface.	Clean the contact surface of old grease and apply a thin film of new grease.
7	Main barrier	Contamination and discoloration	Visual check	There should be no foreign matter. There should be no tracking marks, cracks or damages.	Clean with pressurized air and then wipe with a clean cloth. Replace when damaged.
8	Measurement of insulation resistance	Measuring location	Insulation Resistance	Tester	When the insulation resistance between the main circuit terminals is low, clean the surface of the vacuum interrupter with a dry cloth and then take the measurements again
		Main conductor-Earth/ Main conductors		5000V	
		Control circuit - Earth		500V	
9	Measurement of contact	Measuring location	Resistance	Tester	Check wipe and Contact gaps



SN	CHECK POINT	CHECK ITEM	CHECK METHOD	CRITERIA	ACTION TO BE TAKEN
	resistance	Across each set of contacts		Micro-Ohm meter	
10	Timing Test	Across each set of contacts	Trip test & Close test		Close time - less than 50 ms. Trip time - less than 50 ms

6.3.2 For M/s ABB (Model No. UniGear ZS1)

6.3.2.1 Inspections and Functionality Tests

❖ Interruption devices in general

- Check the conditions of the interruption devices with regular inspections.
- Inspection at fixed intervals can be avoided when the apparatus is permanently under the control of qualified personnel.
- The checks must, first of all, include visual inspection to check for any contamination, traces of corrosion or electrical discharge phenomena.
- Carry out more frequent inspections when there are unusual operating conditions (including severe climatic conditions) and in the case of environmental pollution (e.g. high level of contamination or an atmosphere with aggressive agents).
- Visual inspection of the isolating contacts.
- It is recommended to turn the contact system alternately in order to keep the internal surface of the contact areas clean. The contact areas must be cleaned when there are signs of overheating (discolored surface) (also see Repairs).
- In the case of abnormal conditions, take suitable overhauling measures.

❖ Stored energy operating mechanism

- Carry out the functional test of the operating mechanism after 5,000 operations (2,000 operations for 3150 A circuit- breakers) or during ordinary maintenance operations. Before doing the test, open the circuit-breaker and carry out the following operations:
 - In the case of withdrawable circuit-breakers, take the circuit-breaker to the isolated for test position
 - In the case of fixed circuit-breakers: cut off the power supply to the medium voltage circuit.

6.3.2.2 Functional test

- With the circuit-breaker not connected to the load, carry out a few opening and closing operations.
- If foreseen, cut the power supply to the spring charging motor off. Discharge the spring by closing and opening the circuit-breaker by means of the closing and opening pushbuttons.
- Visually inspect the lubrication conditions of the tulip isolating contacts, of the sliding surfaces, etc.

- Check correct electrical and mechanical operation of the various devices, with particular attention to the interlocks.
- The screws and nuts are tightened in the factory and correct tightening is marked with a collared sign. No further tightening operations are foreseen during the operating life of the circuit-breaker. However, following any maintenance interventions, should it be necessary to re-tighten the screws or nuts, it is recommended to always replace the screws and nuts.

6.3.2.3 Withdrawable assembly (CB)

- Visually inspect the components, especially those which may be damaged by incorrect operations.
- Visually inspect the isolating contacts and that all the contact elements are clean, especially in cases where signs of overheating are found.
- Visually inspect and carry out the functional tests of the locks, checking their correct operation and activation without abnormal force.

6.3.3 For M/s Schneider Electric

Table 8: Maintenance of VCB Panel Make: Schneider Electric

SN	Part	Check	Action to be Taken
1	Device	Check the general condition of the Cover, Frame, Racking device and Shutter Ramp, MV connection & Cluster, LV Connection	
2	Mechanism	Operate (Open/ Close) the device manually and electrically	
		Charge the device electrically and check the charging time	
		Check the complete closing of the device poles	
		Check the number of operation cycles of device	
3	Breaking Device	Check the cleanliness of the device (Chair, Insulating cover, VI sleeve)	
4	Auxiliaries	Check auxiliary wiring and insulation	
5	Device Locking for Fixed Circuit Breaker	Operate device key locking	
		Operate device padlocking	
6	Racking Device for Withdrawable Circuit Breaker	Check the device racking interlock	
		Check the Racking-In & Racking-Out position contacts	
		Check the operation of Shutter Ramp	
		Operate the racking device manually	
		Operate the racking device electrically for motorized circuit breaker	
		Check the number of racking operating cycles	
7	Racking Device Locking	Operate the electromagnet	



CHAPTER 7

TROUBLESHOOTING AND SOLUTIONS

Troubleshooting HT VCB panels ensures safety, reliability, and efficient power distribution. It helps prevent breakdowns, equipment damage, and hazards by detecting faults like insulation failure or contact wear early. Regular checks for loose connections, moisture, and relay issues improve performance, extend lifespan, and ensure uninterrupted power supply.

Some of general failures, probable causes and their possible solutions of indoor type VCB panels are mentioned below as per the OEMs:

7.1 FOR M/S LAURITZ KNUDSEN (FORMERLY L&T)

Table 9: Troubleshooting for VCB Panel Make: Lauritz Knudsen

Diagnose the problem	Identify the probable causes	Solution
Mechanism		
Can Not Close	Closing spring damaged or dislocated	Replace
	Closing catch seized or galled	
	Closing paddle dislocated.	
	Closing coil burnt.	
	Motor burnt	
Closing Sound but Breaker Remains Open	Resetting spring and links fail to reset.	Alignment
	Trip catch/trip shaft fails to reset.	
	Interlock not properly aligned.	Replace if necessary
	Trip coil armature fails to reset.	
Close Without Closing Signal	Main shaft galled.	Replace
	Closing catch fails to reset.	Realign
Cannot trip	Main shaft fails to reset.	
	Trip coil burnt or galled.	Replace
	Trip shaft and catch galled.	
	Trip paddle dislocated.	
Main shaft galled.		
Tripping sound but breaker Remains closed	Link galled.	Replace
Trip Without Tripping Signal	Trip catch damaged Control	Replace
Control Circuit		
Cannot close	Auxiliary switch poor contact or burnt.	Replace switch
	Control relay poor contact or burnt.	Replace PCB
	Auxiliary relay poor contact or burnt.	
	PCB connector poor contact or burnt.	Replace if necessary
	Microswitch poor contact or burnt.	
Close Without Closing Signal	Short circuit of the closing circuit.	Repair
Cannot trip	Auxiliary switch poor contact or burnt	Replace

Diagnose the problem	Identify the probable causes	Solution
	Trip coil burnt, armature damaged or galled	
	Terminal and connector poor contact or burnt	
Trip Without Tripping Signal	Short circuit of the trip circuit	Replace

7.2 FOR M/S SCHNEIDER ELECTRIC

7.2.1 Circuit Breaker Installed as Fixed or Withdrawable

Table 10: Troubleshooting for both Fixed or Withdrawable Circuit Breaker Make Schneider Electric

Diagnose the problem	Identify the probable causes	Solution
Charging in Service position		
Automatic electrical charging of the mechanism does not occur but the device can be mechanically charged	Missing or insufficient supply voltage for the electrical motor MCH	Check the voltage and the supply circuit conformity ($U > 0.85 U_a$). If the problem persists, replace the MCH.
Closing in Service position		
Device cannot be closed locally or remotely	Device padlocked or key locked in the "open" position	<ul style="list-style-type: none"> Check possibility to release the lock, padlock, electromagnetic lock in accordance with the status of the installation. Bring installation into compliance to release locked state.
	Device mechanically interlocked	<ul style="list-style-type: none"> Check the position of the other device. Bring installation into compliance to release locked state.
	Device not completely connected	Complete the device racking in procedure.
	Closing mechanism is not charged	<ul style="list-style-type: none"> Proceed to a manual charging. If the device is equipped with an electrical motor MCH: check the voltage and the supply circuit conformity ($U > 0.85 U_a$). If the problem persists, replace the electrical motor MCH.
	MX opening release permanently supplied with power	<ul style="list-style-type: none"> There is an opening order. Determine the origin of the order. This order is to be canceled before the device can be closed.
MN undervoltage opening release not supplied with power	<ul style="list-style-type: none"> There is an opening order. Determine the origin of this order 	

Diagnose the problem	Identify the probable causes	Solution
		<ul style="list-style-type: none"> Check the voltage and the supply circuit conformity ($U > 0.85 U_a$). If the problem persists, replace the MN undervoltage release.
	Device is not ready to close	<ul style="list-style-type: none"> Determine the condition blocking the device's "ready to close" state. Resend the closing order.
	XF closing release continuously supplied with power, while device was not "ready to close"	<ul style="list-style-type: none"> Determine the origin of the closing order. This order is to be canceled before the device can be closed. Check the device is ready to close. Resend the closing order.
Tripping in Service position		
Unexpected tripping of the device	Insufficient supply voltage of the MN undervoltage release	Check the voltage and the supply circuit conformity ($U > 0.85 U_a$).
	Unexpected opening order from the MX opening release	<ul style="list-style-type: none"> Determine the origin of the order. Refer to the user guide for your protection, control and monitoring unit.
	One of the following cause occurs: <ul style="list-style-type: none"> overload earth insulation fault short circuit detected by the protection relay 	<ul style="list-style-type: none"> Determine and eliminate the tripping causes. Check the condition of the device before putting it back into service.
Instantaneous tripping after each attempt to close the device	Transient overcurrent when closing	<ul style="list-style-type: none"> Check your distribution system or the settings of your protection relay. Check the condition of the device before putting it back into service.
	Closing on a short circuit	<ul style="list-style-type: none"> Determine and eliminate the tripping causes. Check the condition of the device before putting it back into service.
Opening in Service position		
Device cannot be opened mechanically or electrically	Operating mechanism malfunction or welded contacts	Contact a Schneider Electric representative.
Device cannot be opened electrically, but can be opened mechanically using the opening push	Opening order not executed by the MX opening release	Check the voltage and the supply circuit conformity ($0.7 - 1.1 U_a$ for DC supply) and ($0.85 - 1.1 U_a$ for AC supply). If the problem persists, replace the



Diagnose the problem	Identify the probable causes	Solution
button located on the device		MX opening release.
	Opening order not executed by the MN undervoltage opening release	Drop in voltage insufficient or residual voltage across the terminals of the undervoltage release $> 0.35 U_a$. If the problem persists, replace the MN undervoltage release.

7.2.2 Complement Only for Withdrawable Circuit Breaker

Table 11: Additional Troubleshooting only for Withdrawable Circuit Breaker Make: Schneider Electric

Diagnose the problem	Identify the probable causes	Solution
Racking-in or Racking-out		
Not possible to insert the crank in "Disconnected/ test" or "Service" position	A padlock or keylock is present on the cubicle door	<ul style="list-style-type: none"> Check possibility to release the lock, padlock, in accordance with the status of the installation. Bring installation into compliance to release locked state.
	The racking device is not properly locked in the correct position in the cubicle	Lock the racking device in the correct position in the cubicle.
	The door is open or the door interlock is ineffective	Close the cubicle door or check the operation of the door interlock.
Device cannot be racked to "Service" position	The door is open or the door interlock is ineffective	Close the cubicle door or check the operation of the door interlock.
	Wrong direction of crank rotation	Check the direction of rotation.
	Mechanical problem on the shutters	Check the operation of the shutters.
	Clusters are incorrectly positioned	Re-adjust/Replace clusters.
	Electromagnet not activated	<ul style="list-style-type: none"> Lock the auxiliaries connection plug in the correct position. Activate electromagnet. Refer to Electromagnet troubleshooting.
	The device is closed	Open the device.
	The racking device is not properly locked in the correct position in the cubicle	Lock the racking device in the correct position into the cubicle.
An interlock with Earthing Switch is present	<ul style="list-style-type: none"> Check the position of the Earthing Switch. Check the condition of the switchgear before opening the Earthing Switch. Bring installation into compliance to release locked 	

Diagnose the problem	Identify the probable causes	Solution
		state.
Device cannot be racked out to "Test/Disconnected" position	Electromagnet not activated	<ul style="list-style-type: none"> Lock the auxiliary connection plug in the correct position. Activate electromagnet. Refer to Electromagnet troubleshooting.
	The device is closed	Open the device.
Device insertion or extraction		
Cubicle door cannot be opened	The racking device is not in the "Disconnected/ test position"	Turn the crank until the device reaches the "Disconnected/ Test" position.
Cubicle door cannot be closed	The racking device is not properly locked in the correct position in the cubicle	Lock the racking device in the correct position in the cubicle.
	The door interlock is ineffective	Check the operation of the door interlock.
Device cannot be pulled out	Device is not in the "Disconnected/Test" position	<ul style="list-style-type: none"> Turn the crank until the device reaches the "Disconnected/ Test" position. Check device to cubicle lock is disengaged on both sides.
Device motorization		
No complete racking-in with motorization	Motor fault during racking-in	De-energize the motorization from the LV cabinet. Rack-out manually the racking device.
No complete racking-out with motorization	Motor fault during racking-out	De-energize the motorization from the LV cabinet. Rack-out manually the racking device.
Electromagnet		
Impossible to turn the crank of racking device despite electromagnet activation	Electromagnet is not supplied or power supply value is inadequate	<ul style="list-style-type: none"> Check the electromagnet power supply (connection, wiring continuity, supply voltage value). If the electromagnet is correctly supplied, contact Schneider Electric to replace it.
	The electromagnet is mechanically locked	Contact your Schneider Electric representative to replace the electromagnet.
Crank of racking device can be turned despite electromagnet is powered off	Electromagnet shaft is blocked and does not lock anymore the crank rotation	Check the shaft movement obstruction, and if needed contact your Schneider Electric representative to replace the electromagnet.



REFERENCE

1. IEC Standard “High-voltage switchgear and controlgear: Alternating-current circuit-breakers” IEC 62271- Part 100: 2021.
2. IEC Standard “High-voltage switchgear and controlgear: Common specifications for alternating current switchgear and controlgear” IEC 62271- Part 1:2017.
3. CPWD’s Specification for Electrical Work Part IV- Substation: 2013.
4. M/s ABB’s Installation, Operation and Maintenance Instruction manual of VCB.
5. M/s CG Power and Industrial Solutions Limited’s Installation and Commissioning user manual of MV VCB (Indoor Type).
6. M/s Schneider Electric’s User Guide on Medium Voltage Vacuum Circuit Breaker.
7. M/s Siemens Limited’s Operating Instructions of VCB.
8. M/s Lauritz Knudsen Electrical & Automation’s (Formerly L&T) O&M Manual of Vacuum Circuit Breaker.
9. Some of the content from Internet.



CONTACT US

CAMTECH is continuing its efforts in the documentation and up-gradation of information on maintenance practices of electrical assets. Over the years a large number of publications on electrical assets have been prepared in the form of handbooks, pocket books, pamphlets and video films, etc. These publications have been uploaded on the internet as well as rail net.

Link for downloading CAMTECH publications:

On internet visit: <https://indianrailways.gov.in/> Or

On Railnet visit Railway Board website at <http://10.1.2.21/>

Go to Indian Railways → Directorates → Efficiency & Research → CAMTECH, Gwalior → Publications for download Or

Link for directly download the Publications:

https://indianrailways.gov.in/railwayboard/view_section.jsp?lang=0&id=0,1,304,366,538,2713,2718,2722

For any further information, regarding publications please contact:

Director (Elect.) BSNL	:	0751- 2470740 (O)
Rly.	:	03747202
SSE/ Electrical	:	8957022145 (CUG)
E-mail	:	direlcamtech@gmail.com
Fax	:	0751- 2470841
Write at	:	Director (Electrical)

Indian Railways, Centre for Advanced Maintenance Technology

In front of Hotel Adityaz, Airport Road, Maharajpura, Gwalior, Pin Code-474005.

